

OKI

OKIPAGE 14e LED Page Printer

Maintenance Manual

ODA / OEL / INT

2001-03-19 Rev.2

Document Revision History

Rev.No.	Date	Corrected items			Person in charge
		No.	Page	Description of change	
1	2000-12-08			ISSUE	ODC Miyashita
2	2001-03-19				NP39 H Ono

PREFACE

This Maintenance Manual describes the field maintenance methods for OKIPAGE 14e LED Page Printers.

This manual is written for use by the maintenance personnel. Please note that you should refer to the Printer Handbook and Printer Setup for the handling and operating methods of the equipment.

Contents

1.	CONFIGURATION	7
1.1	System Configuration	7
1.2	Printer Configuration	8
1.3	Optional Configuration	9
1.4	Specification	11
1.5	Safety Standards	13
1.5.1	Certification Label	13
1.5.2	Warning Label	13
1.5.3	Warning/Caution Marking	14
2.	OPERATION DESCRIPTION	15
2.1	Main Control Board	17
2.2	Power Supply/Sensor Board	18
2.3	Electrophotographic Process	20
2.3.1	Electrophotographic Process Mechanism	20
2.3.2	Electrophotographic Process	22
2.3.3	Process Operation Descriptions	25
2.4	Paper Jam Detection	35
2.5	Cover Open	37
2.6	Toner Low Detection	38
3.	PARTS REPLACEMENT	40
3.1	Precautions for Parts Replacement	40
3.2	Parts Layout	42
3.3	How to Change Parts	45
3.3.1	Upper Cover Assy	46
3.3.2	IC Card Cover	47
3.3.3	LED Head	48
3.3.4	Operator Panel Assy	49
3.3.5	Lower Base Unit	50
3.3.6	Pulse Motor (Main/Drum)	51
3.3.7	Pulse Motor (Registration)	52
3.3.8	Face Up Stacker Assy	53
3.3.9	Eject Roller Assy	54
3.3.10	Motor Assy	55
3.3.11	Hopping Roller Shaft Assy	56
3.3.12	Stacker Cover Assy	57
3.3.13	Registration Roller	58
3.3.14	Roller Transfer Assy	59
3.3.15	Fusing Unit	60
3.3.16	Back-up Roller	61
3.3.17	Sensor Plate (Inlet)	62
3.3.18	Sensor Plate (Outlet), Sensor Wire Assy	63
3.3.19	Manual Feed Guide Assy	64
3.3.20	Sensor Plate (Paper Supply)	65
3.3.21	M7G-PCB	66
3.3.22	Power Supply/Sensor Board, High Voltage Unit and Contact Assy	67
3.3.23	Cassette Guide L Assy	68
3.3.24	Cassette Guide R Assy	69
3.3.25	Spacer Bearing (L/R)	70
4.	ADJUSTMENT	71
4.1	Adjustment Types and Functions	71
4.1.1	Status Monitor	71

4.1.2	Engine Maintenance Utility	71
4.2	Adjustment When Replacing a Part	72
4.2.1	Setting of LED Head Drive Time	72
4.2.2	Uploading and Downloading EEPROM Data	73
5.	PERIODICAL MAINTENANCE	74
5.1	Periodical Replacement Parts	74
5.2	Cleaning	74
5.2.1	Cleaning of LED Lens Array	74
6.	TROUBLESHOOTING PROCEDURES	76
6.1	Troubleshooting Tips	76
6.2	Check Points Before Correcting Image Problems	76
6.3	Notes When Correcting Image Problems	76
6.4	Preparation Before Troubleshooting	76
6.5	Troubleshooting	78
6.5.1	Status Monitor Message List	78
6.5.2	Status Message Troubleshooting	82
6.5.3	Image Troubleshooting	90
7.	WIRING DIAGRAM	99
7.1	Interconnect Signal Diagram	99
7.2	PCB Layout and Connector Signal List	100
7.3	Resistance Check	110
8.	PARTS LIST	112
Appendix A	RS-232C SERIAL INTERFACE (option)	119
Appendix B	CENTRONICS PARALLEL INTERFACE	121
Appendix C	UNIVERSAL SERIAL BUS (USB).....	125
Appendix D	MAINTENANCE UTILITY GUI MANUAL	129
1.	Overview	129
1.1	System Requirements	129
2.	Utility Starting-Time Operation	129
3.	Main Set Property Sheet	130
3.1	Printer Status Group	130
3.2	LED Head Marking No.	133
3.3	Descriptions on Buttons	134
4.	Menu Property Sheet	136
4.1	Setting Items	137
5.	Local Print Property Sheet	140
6.	Product Set Property Sheet	142
7.	About Property Sheet	143
8.	For Invalid Events	144
8.1	Failed Printer Setting	144
8.2	RAM Check Error.....	144
Appendix E	MULTI-PURPOSE FEEDER	134
1.	OUTLINE	145
1.1	Functions	145
1.2	External View and Component Names	145

2.	MECHANISM DESCRIPTION	146
2.1	General Mechanism	146
2.2	Hopper Mechanism	146
3.	PARTS REPLACEMENT	147
3.1	Precautions Concerning Parts Replacement	147
3.2	Parts Layout	149
3.3	Parts Replacement Methods	150
3.3.1	Link	151
3.3.2	Separator	152
3.3.3	OLEV-11-PCB	153
3.3.4	Pulse Motor	154
3.3.5	Planet Gear	155
3.3.6	Roller-A and B	156
4.	TROUBLESHOOTING	157
4.1	Precautions Prior to the Troubleshooting	157
4.2	Preparations for the Troubleshooting	157
4.3	Troubleshooting Method	158
4.3.1	LED Status Message List	158
5.	CONNECTION DIAGRAM	160
5.1	Interconnection Diagram	160
5.2	PCB Layout	160
6.	PARTS LIST	161
Appendix F HIGH CAPACITY SECOND PAPER FEEDER MAINTENANCE ...		163
1.	OUTLINE	163
1.1	Functions	163
1.2	External View and Component Names	163
2.	MECHANISM DESCRIPTION	164
2.1	General Mechanism	164
2.2	Hopper Mechanism	164
3.	PARTS REPLACEMENT	165
3.1	Precautions Concerning Parts Replacement	165
3.2	Parts Layout	167
3.3	Parts Replacement Methods	168
3.3.1	Stepping Motor (Hopping)	169
3.3.2	TQSB-2 PCB	171
3.3.3	Hopping Roller Shaft Assy and One-way Clutch Gear	171
4.	TROUBLESHOOTING	172
4.1	Precautions Prior to the Troubleshooting	172
4.2	Preparations for the Troubleshooting	172
4.3	Troubleshooting Method	173
4.3.1	LED Status Message List	173
5.	CONNECTION DIAGRAM	175
5.1	Interconnection Diagram	175
5.2	PCB Layout	175
6.	PARTS LIST	176

1. CONFIGURATION

1.1 System Configuration

OKIPAGE 14e consists of control and engine blocks in the standard configuration, as shown in Figure 1-1.

In addition, the options marked with asterisk(*) are available.

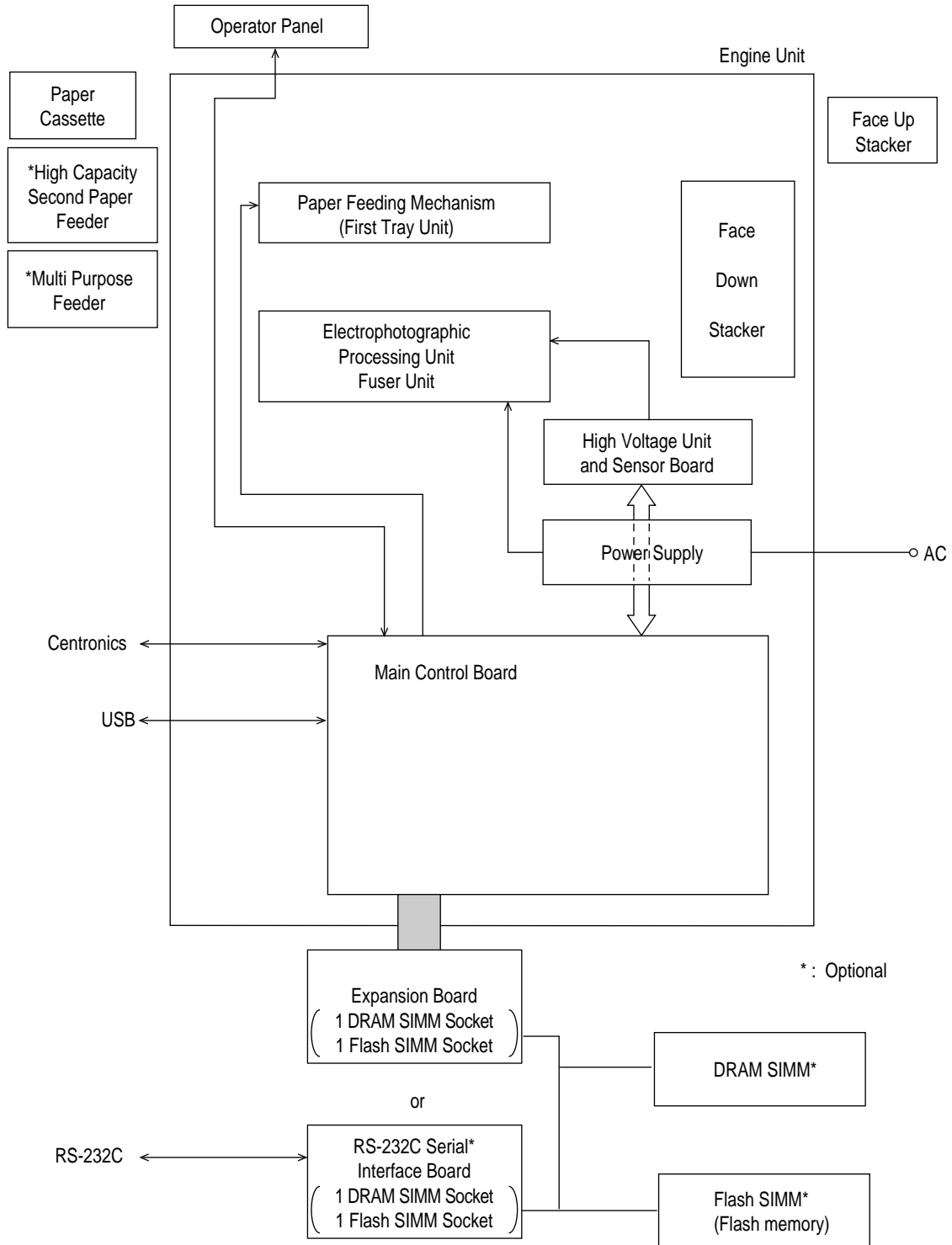

Figure 1-1

1.2 Printer Configuration

The printer unit consists of the following hardware components:

- Electrophotographic Processor
- Paper Feeder
- Controller
- Operator Panel
- Power Supply Unit

The printer unit configuration is shown in Figure 1-2.

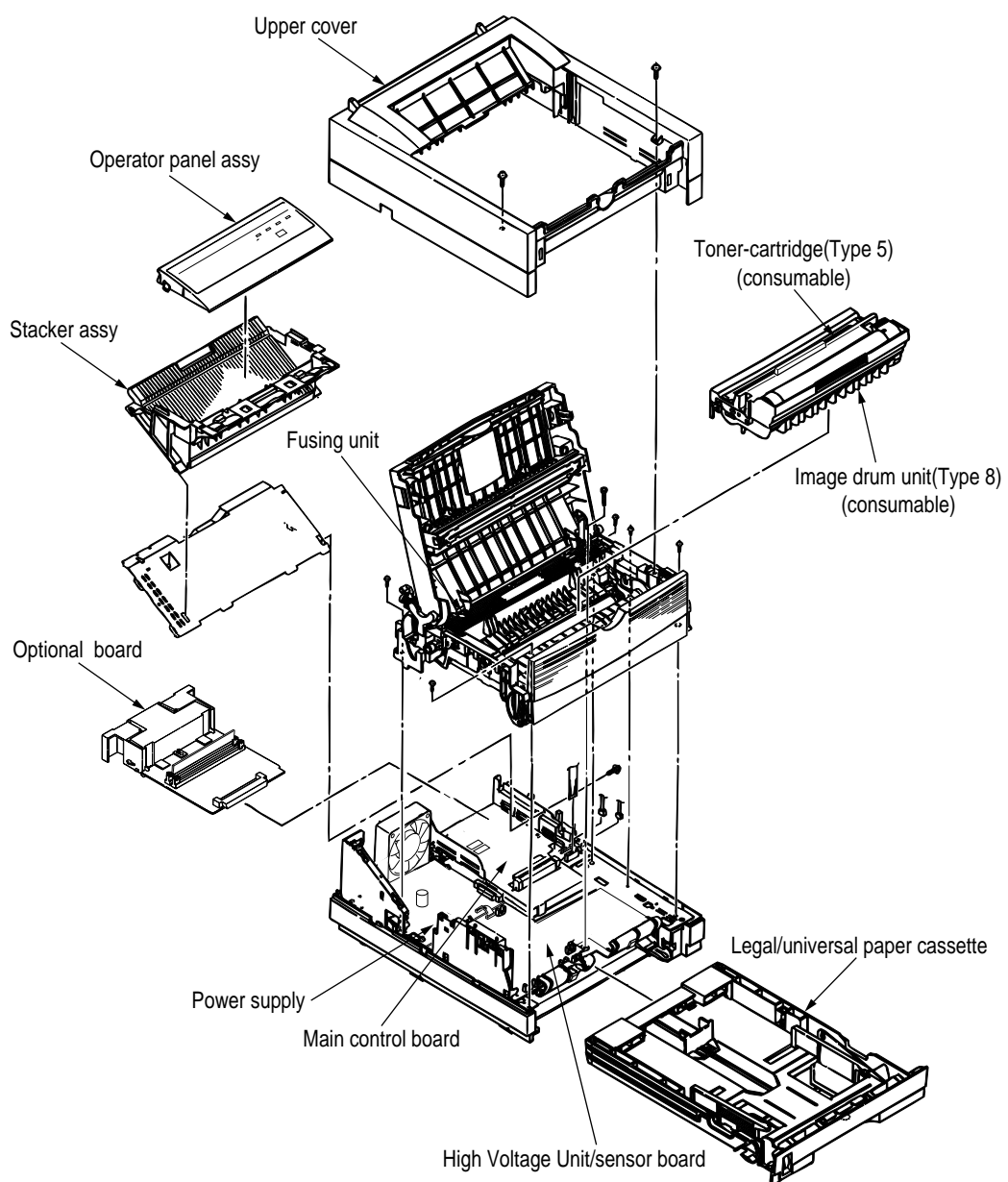
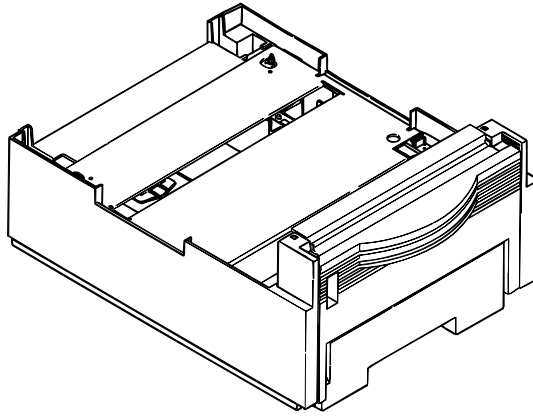

Figure 1-2

1.3 Optional Configuration

The options shown below are available for use with OKIPAGE 14e. These are available separately from the printer unit.

- (1) High Capacity Second Paper Feeder



- (2) Multi Purpose Feeder

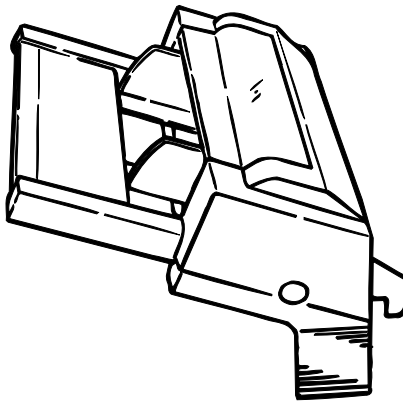

- (3) Expansion Board

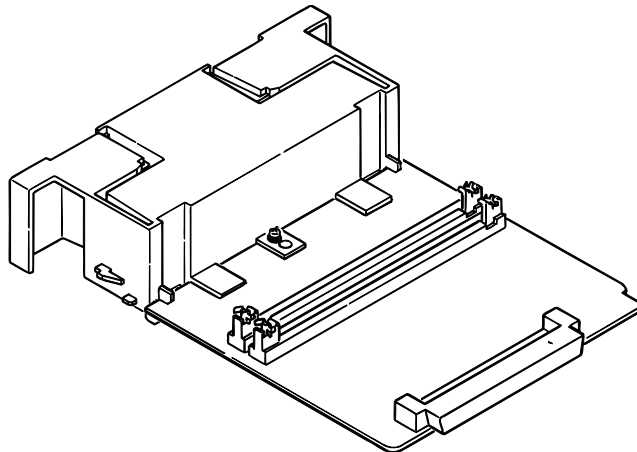

(4) RS-232C Serial Interface Board

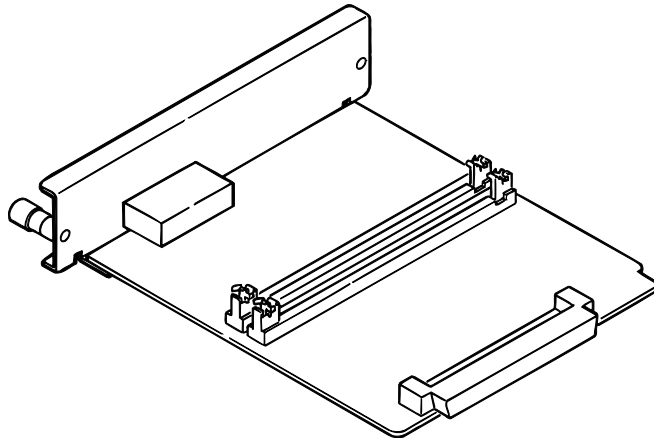

(5) DRAM SIMM Memory

DRAM SIMM memory is available with memory of 8MB,16MB,32MB [Oki Data genuine].
The access time of SIMM memories are 60ns, 70ns, 80ns, and 100ns.

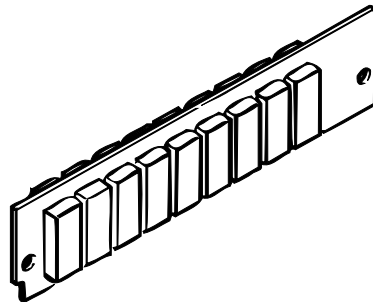

(6) Flash SIMM

Flash SIMM is available with memory of 4MB, 8MB and 16MB.

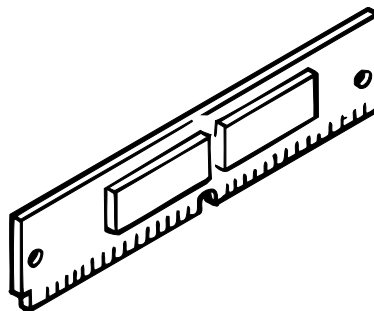

1.4 Specification

(1) Type	Desktop
(2) External dimensions	Height 7.9" (200 mm) Width 13.0" (330 mm) Depth 15.6" (395 mm)
(3) Weight	Approx. 9 kg
(4) Developing method Exposing method	Dry electrophotography LED stationary head
(5) Paper used	<Type> <ul style="list-style-type: none">• Standard paper<ul style="list-style-type: none">– Xerox 4200 (20 lbs)• Application paper (manual face-up feed)<ul style="list-style-type: none">– Label– Envelope– OHP paper (transparency) <Size> <ul style="list-style-type: none">• Standard sizes<ul style="list-style-type: none">– Letter– Legal* [*Without Multi Purpose Feeder (Option)]– Legal-13*– Executive– COM-10** [**manual feed and Multi Purpose Feeder (Option) only]– Monarch**– DL**– C5**– A4– A5– B5 (JIS)– A6• Applicable sizes<ul style="list-style-type: none">– Width: 3.4" to 8.5" (86 to 216 mm)– Length: 5.5" to 14" (140 to 355.6 mm) <Thickness> <ul style="list-style-type: none">– Automatic feed: 16 to 28 lbs (60 to 105 g/m²)– Manual feed: Label, OHP paper (transparency) Envelope (24 to 28lbs)
(6) Printing speed	Continuous printing: 14 pages per minute with Letter size paper. [Except Multi purpose Feeder (10.7ppm)] Warm-up time: 45 seconds typical at room temperature [68°F (20°C), AC 120/230 V]. First page print time: 7.5 seconds typical for the Letter size paper after warm-up.
(7) Paper feeding method	Automatic feed or manual feed
(8) Paper delivery method	Face down/face up
(9) Resolution	300 × 300 dots/inch 300 × 1200 dots/inch

(10) Power input 120 V + 6%, -15%
 230 VAC ± 10%

(11) Power consumption

		120VAC	230VAC
Peak	:	Approx. 600W	Approx. 600W
Typical operation	:	Approx. 340W	Approx. 340W
Idle	:	Approx. 75W	Approx. 66W
Power save mode	:	Approx. 10W	Approx. 11W

(12) Temperature and humidity

	In operation	Power off mode	During Storage	Unit
Temperature	50-90 (10-32)	32-110 (0-43)	14-110 (-10-43)	°F (°C)
Humidity	20-80	10-90	10-90	%RH
Maximum wet bulb temperature	77 (25)	80.4 (26.8)	————	°F (°C)
Minimum difference between wet and dry bulb temperatures	35.6 (2)	35.6 (2)	————	°F (°C)

1. Storage conditions specified above apply to printers in packed condition.
2. Temperature and humidity must be in the range where no condensation occurs.

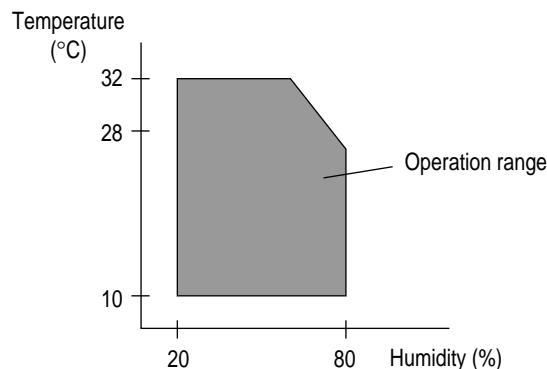

(13) Noise

During operation	:	53 dB (A) or less
Standby	:	38 dB (A) or less
Quiet mode	:	Back ground level

(14) Consumables

Toner cartridge kit	ODA	: 2,000 (5% duty)
	OEL/INT	: 2,500 (5% duty)
Image drum cartridge		20,000 (at continuous printing)
		14,000 (3 page/job) without Power Save
		9,000 (1 page/job) without Power Save
		8,000 (1 page/job) without Power Save (Minimum)

1.5 Safety Standards

1.5.1 Certification Label

The safety certification label is affixed to the printer in the position described below.

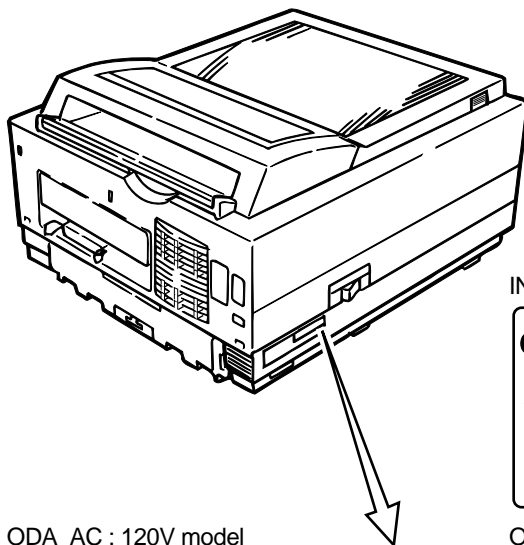

INT AC : 230V model

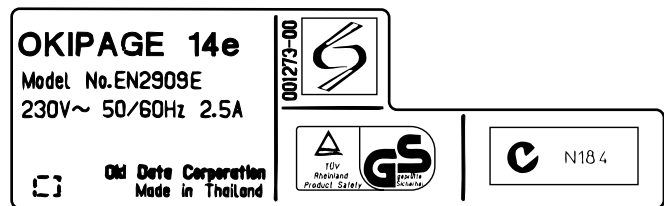

ODA AC : 120V model

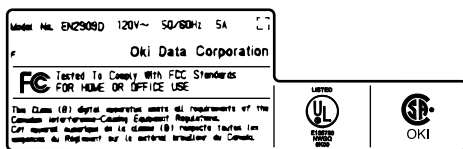

ODA AC : 230V model

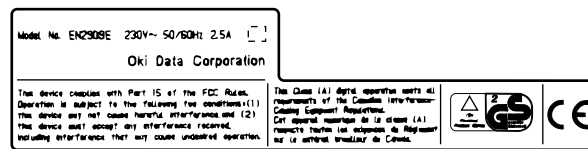

1.5.2 Warning Label

The warning labels are affixed to the sections which may cause bodily injury.

Follow the instructions on warning labels during maintenance.

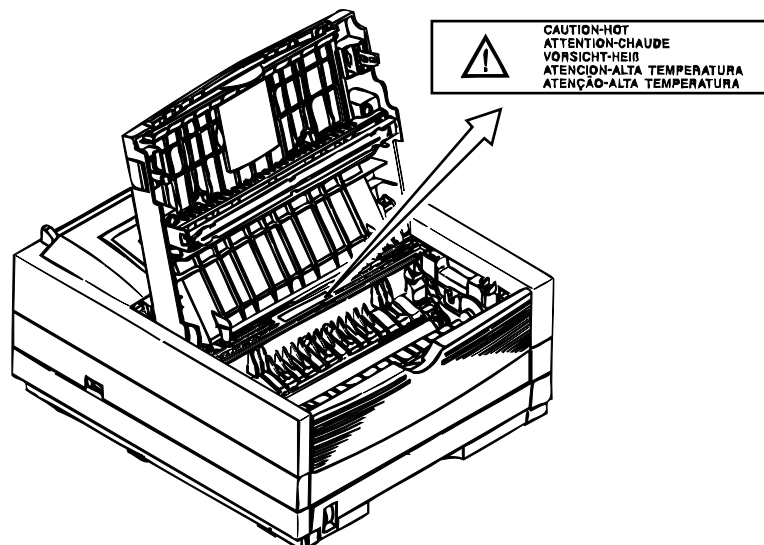

1.5.3 Warning/Caution Marking

The following warning and caution markings are made on the power supply/sensor board.

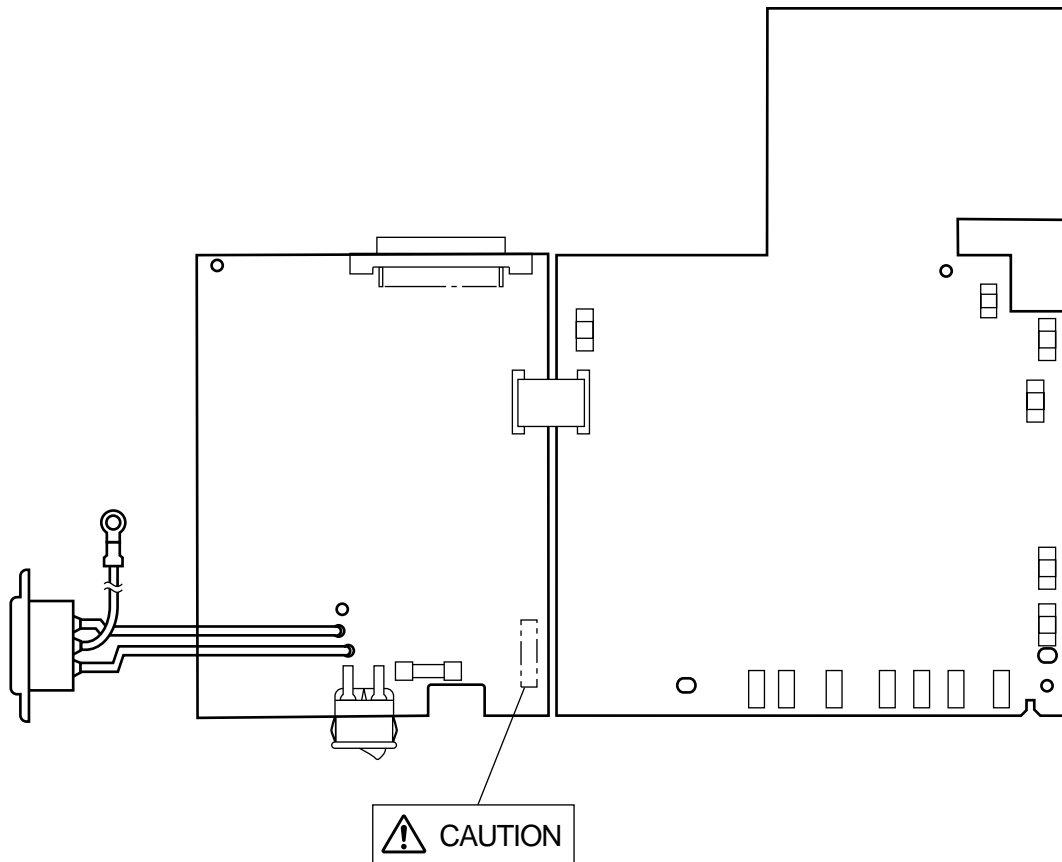

ENGLISH

Heat sink and transformer core present risk of electric shock. Test before touching.

FRENCH

Le dissipateur thermique et le noyau du transformateur présentent des risques de choc électrique. Testez avant de manipuler.

SPANISH

Las disipadores de calor e el núcleo del transformador pueden producir un choque eléctrico. Compruebe antes de tocar.

PORTUGUESE

O dissipador de calor e o núcleo do transformador apresentam risco de choque elétrico. Teste antes de tocar.

ENGLISH

Circuits maybe live after fuses open.

FRENCH

Il se peut que les circuits soient sous tension une fois que les fusibles ont été retirés.

SPANISH

Las circuitos pueden estar activos una vez que se hayan abierto los fusibles.

PORTUGUESE

Os circuitos podem estar energizados após os fusíveis se queimarem.

2. OPERATION DESCRIPTION

OKIPAGE 14e consists of a main control board, a power supply/sensor board, an operator panel, an electrophotographic process mechanism, and revision for illumination of LED head.

The main control board receives data via the host I/F, it then decodes, edits and stores the data in memory. After completing the editing of a single page of data, it references the font memory and generates bit image data, which is transferred to the LED head in one dot line units.

Through the electrophotographic process mechanism, the data is printed on the paper.

The operator panel is used for operations and status display.

OKIPAGE 14e block diagram is shown in Figure 2-1.

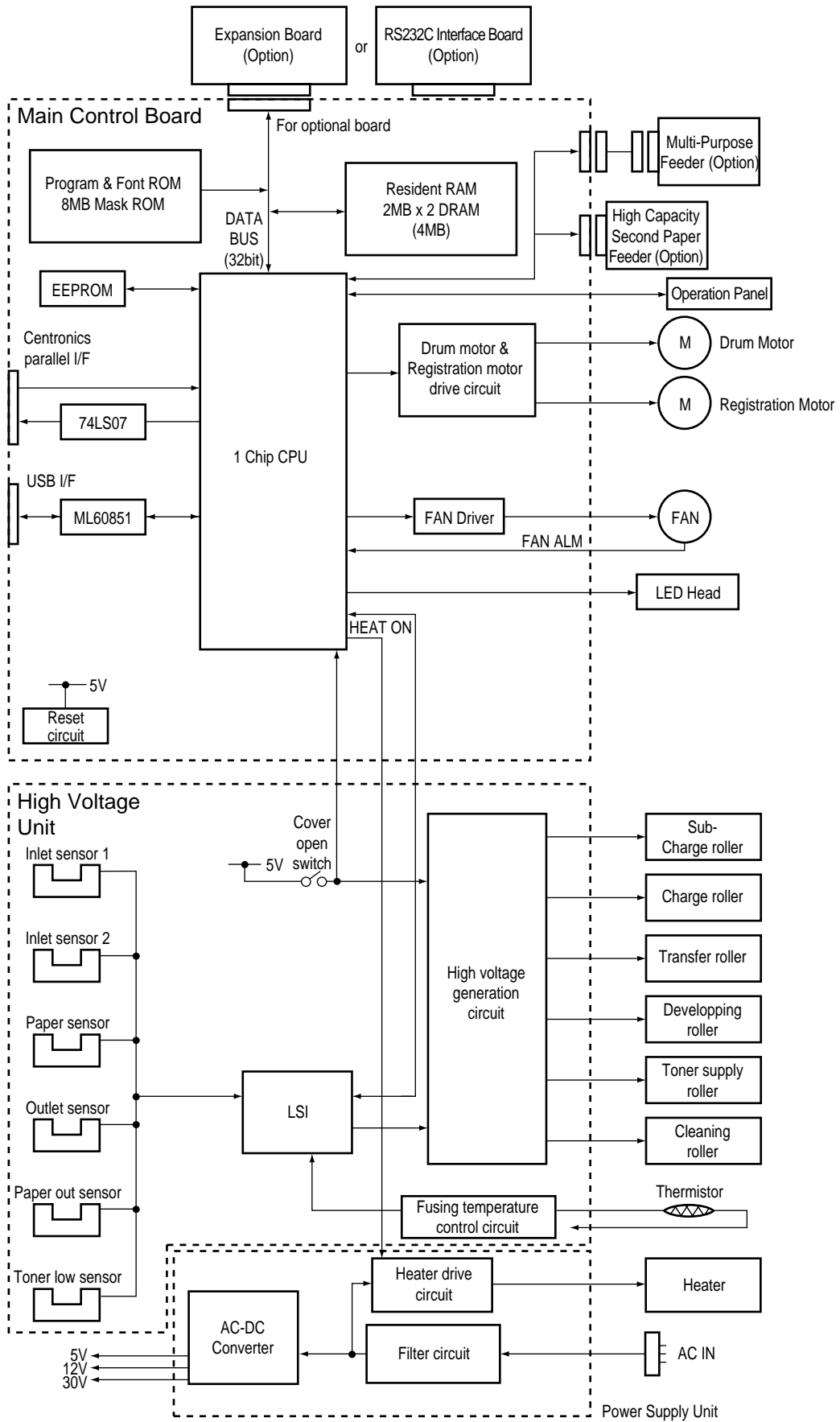

Figure 2-1 OKIPAGE 14e Block Diagram

2.1 Main Control Board

The main control board consists of a single chip CPU, two program/font ROMs, four DRAMs, an EEPROM, a host interface circuit, and a mechanism driving circuit.

(1) Single chip CPU

The single chip CPU is a custom CPU (32-bit internal bus, 32-bit external bus, 49.766-MHz clock) which incorporates the RISC CPU and its peripheral devices, and has the following functions:

Built-in device	Function
Chip select controller Bus controller DRAM controller	Control of ROM, DRAM and I/O device
DMA controller	Transfer of image data from DRAM to video output port
Parallel interface controller	Control of Centronics parallel interface
Serial interface controller	Control of RS-232C serial interface
Video output port LED STB output port	Control of LED head
Timer	Generation of various control timing Monitoring of paper running and paper size
Serial I/O port	Control of operator panel, EEPROM, and options
I/O port	Input and output of sensor and motor signals

(2) Program and Font ROMs

The Program and Font ROMs store the equipment program and various types of fonts. Mask ROM is used as Program and Font ROMs. The mounting locations of these Program and Font ROMs vary depending on the type of the ROMs.

(3) DRAM

The DRAM is a 4MB resident memory on the main control board that stores edited data, image data, DLL data and macro data.

(4) EEPROM

4,096-bit Electrically Erasable PROM (EEPROM), is loaded with the following kinds of data:

- Menu data
- Various counter data (page counter, drum counter)
- Adjusting parameters (LED head drive time, print start position, paper feed length)

(5) Parallel Interface

Parallel data is received from a host system via parallel interface which conforms to the IEEE1284 specification.

(6) USB Interface

Serial data is received from a host system via USB which conforms to the USB 1.1 specification.

2.2 Power Supply/Sensor Board

The power supply/sensor board consists of an AC filter circuit, a low voltage power supply circuit, a high voltage power supply circuit, heater drive circuit, and photosensors.

(1) Low Voltage Power Supply Circuit

This circuit generates the following voltages.

Output voltage	Use
+5 V	Logic circuit supply voltage and LED head supply voltage
+30 V	Motor and fan drive voltage
+12 V	Source voltage for high-voltage supply

(2) High Voltage Power Supply Circuit

This circuit generates the following voltages required for electrophotographic process from +5 V, according to the control sequence from the main control board. When cover open state is detected, +5 V supply is interrupted automatically to stop the supply of all high-voltage outputs.

Output	Voltage	Use	Remarks
CH	-1.3 KV	Voltage applied to charge roller	
Sub CH	-1.5 KV to -1.8 KV	Voltage applied to sub-charge roller	
DB	-265 V/+300 V	Voltage applied to developing roller	
SB	-500 V/ 0 V	Voltage applied to toner supply roller	
TR	+500 V to +4.5 KV/-1100 V	Voltage applied to transfer roller	Variable
CB	+400 V/-1350 V	Voltage applied to cleaning roller	

(3) Photosensor

The photosensor mounted on this power supply/sensor board monitors the status of paper being fed through the printer during printing.

The sensor layout diagram is shown in Figure 2-2.

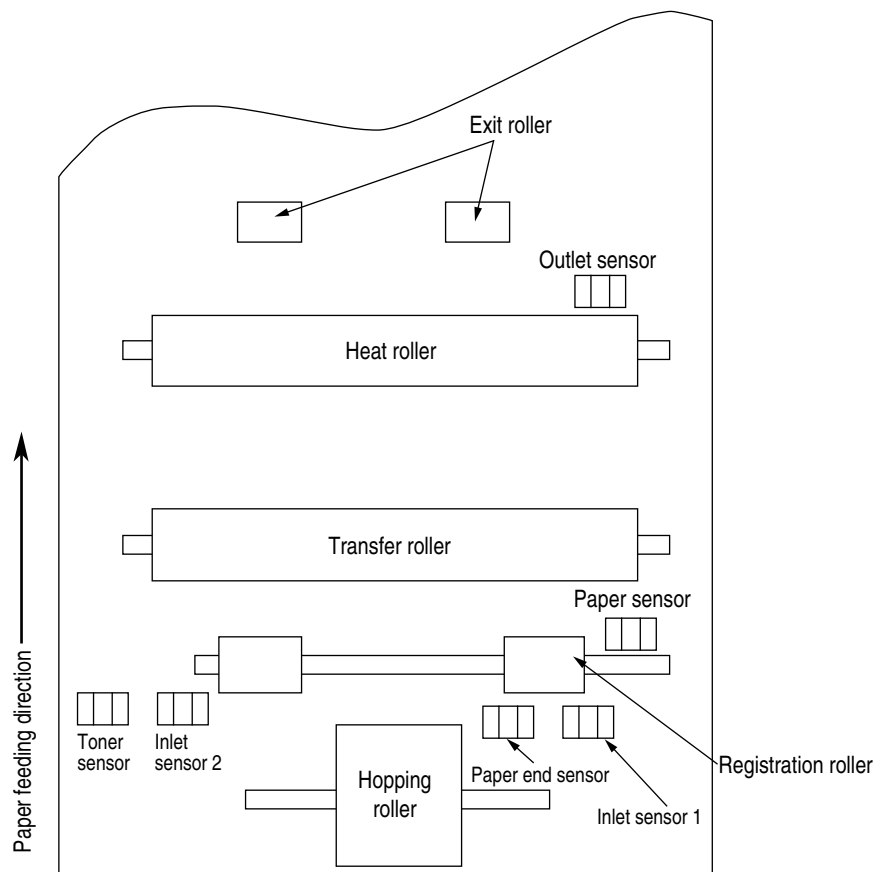

Figure 2-2

Sensor	Function	Sensing state
Inlet sensor 1	Detects the leading part of the paper and gives the monitor timing for switching from hopping operation to feeding operation. Monitors paper feeding situation and paper size based on the paper arrival time and running time.	ON: Paper exists. OFF: No paper exists.
Inlet sensor 2	Detects the paper width.	ON: larger than A4 OFF: Smaller than A4
Paper sensor	Detects the leading portion of the paper. Monitors the paper feeding situation.	ON: Paper exists. OFF: No paper exists.
Outlet sensor	Monitors the paper feeding and size according to the time of arrival to and leaving past the sensor.	ON: Paper exists. OFF: No paper exists.
Paper end sensor	Detects the end of the paper.	ON: Paper exists. OFF: No paper exists.
Toner low sensor	Detects the lack of toner.	-----

2.3 Electrophotographic Process

2.3.1 Electrophotographic Process Mechanism

This mechanism actuates the printing of image data supplied by the main control board on the paper by electrophotographic process.

The layout of the electrophotographic process mechanism is shown in Figure 2-3.

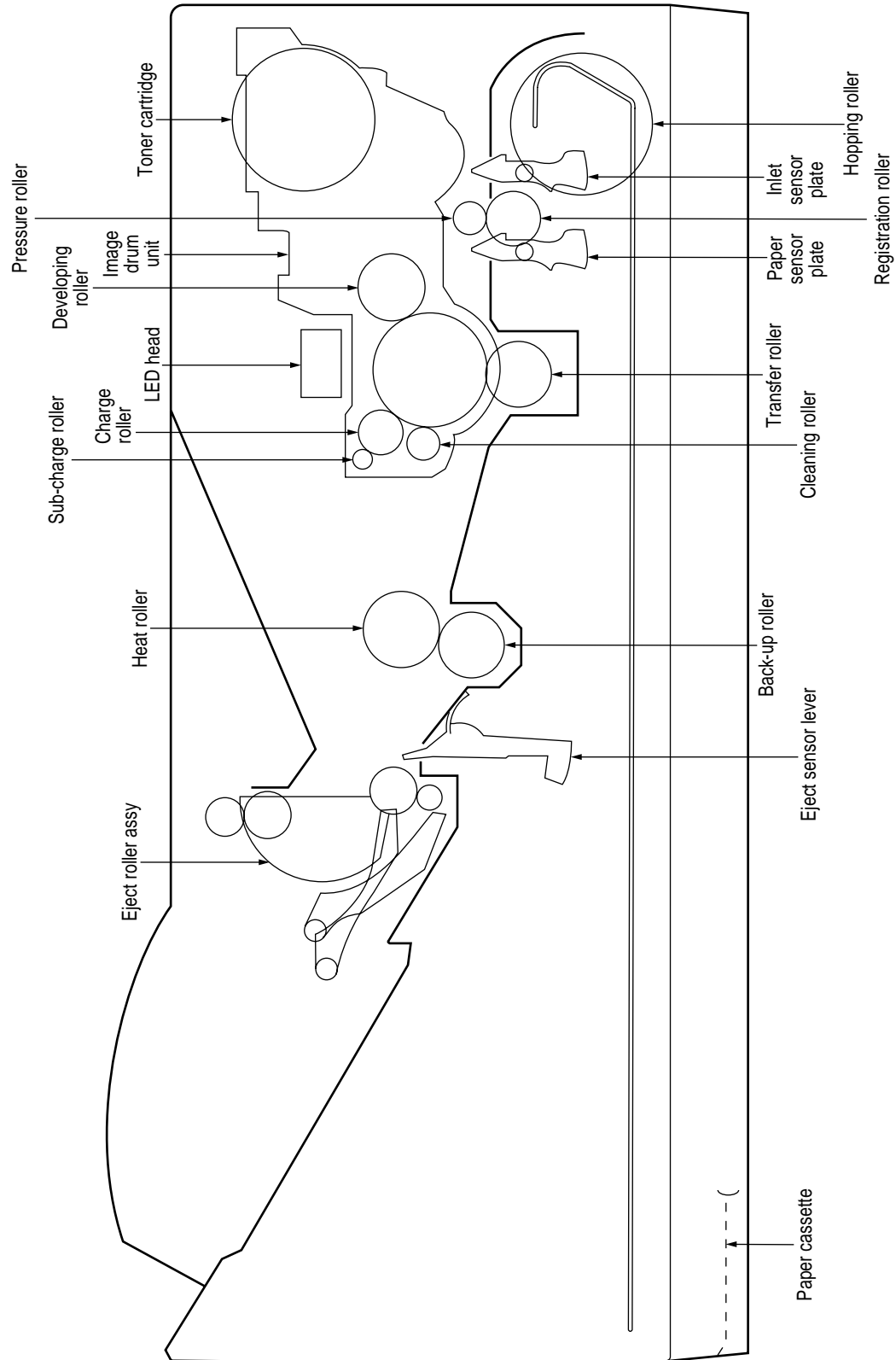

Figure 2-3

(1) Image Drum Unit

The image drum unit consists of a sensitive drum, a charger, and a developer. The unit forms a toner image on the sensitive drum, using an electrostatic latent image formed by the LED head.

(2) Registration Motor

The registration motor is a pulse motor of 48 steps/rotation with two-phase excitement by the signal from the main control board. It drives the hopping and registration rollers via two one-way clutches according to the direction of rotation.

(3) Main (Drum) Motor

The main or drum motor is a pulse motor of 48 steps/rotation with two-phase excitement by the signal from the main control board and is the main motor of this mechanism.

(4) LED Head

Image data for each dot line from the main control board is received by the shift register and latch register. The 2496 LED's are driven to radiate the image data on the image drum.

(5) Fuser

The fuser consists of a heater, a heat roller, a thermistor and a thermostat.

The AC voltage from the power supply/sensor board is applied to the heater controlled by the HEATON signal from the main control board. This AC voltage heats the heater. The main control board monitors the heat roller temperature via the thermistor, and regulates the heater roller to keep it at a designated temperature in the menu, depending on the thickness of the paper (tray 1&2: light=175~185°C, medium light=180~190°C, medium=185~195°C, medium heavy and heavy=195~205°C; manual feeding and power envelope feeder: light=165~180°C, medium light=170~185°C, medium=175~190°C, medium heavy=180~195°C, heavy=190~205°C, transparency = 170~185°C) by connecting or disconnecting the AC voltage supply to the heater.

When an abnormal rise of the heater roller temperature takes place, the thermostat of the heater voltage supply circuit becomes active and forcibly cuts the AC voltage supply.

The temperature setting of the fuser can be changed through operator panel setting.

2.3.2 Electrophotographic Process

The electrophotographic processing is outlined below. The electrophotographic printing process is shown in Figure 2-4.

① Charging

The surface of the image drum is charged uniformly with a negative charge by applying the negative voltage to the charge roller.

② Exposure

Light emitted from the LED head irradiates the negatively charged surface of the image drum. The surface potential of the irradiated portion of the image drum surface becomes lower, forming the electrostatic latent image associated with the print image.

③ Developing and toner recovery

When the negatively charged toner is brought into contact with the image drum, it is attracted to the electrostatic latent image by static electricity, making the image visible.

At the same time, the residual toner on the image drum is attracted to the developing roller by static electricity.

④ Transfer

When paper is placed over the image drum surface, the positive charge which is opposite in polarity to that of the toner, is applied to the reverse side of the paper by the transfer roller. The toner is attracted by the positive charge and is transferred onto the paper. This results in the transfer of the toner image formed on the image drum onto the paper.

⑤ Temporary cleaning

Residual toner which remains on the image drum without being transferred is evened out by the cleaning roller and is temporarily attracted to the cleaning roller by static electricity.

⑥ Fusing

The toner image transferred onto the paper is fused to the paper by heat and pressure.

An electrophotographic process timing chart is shown in Figure 2-5.

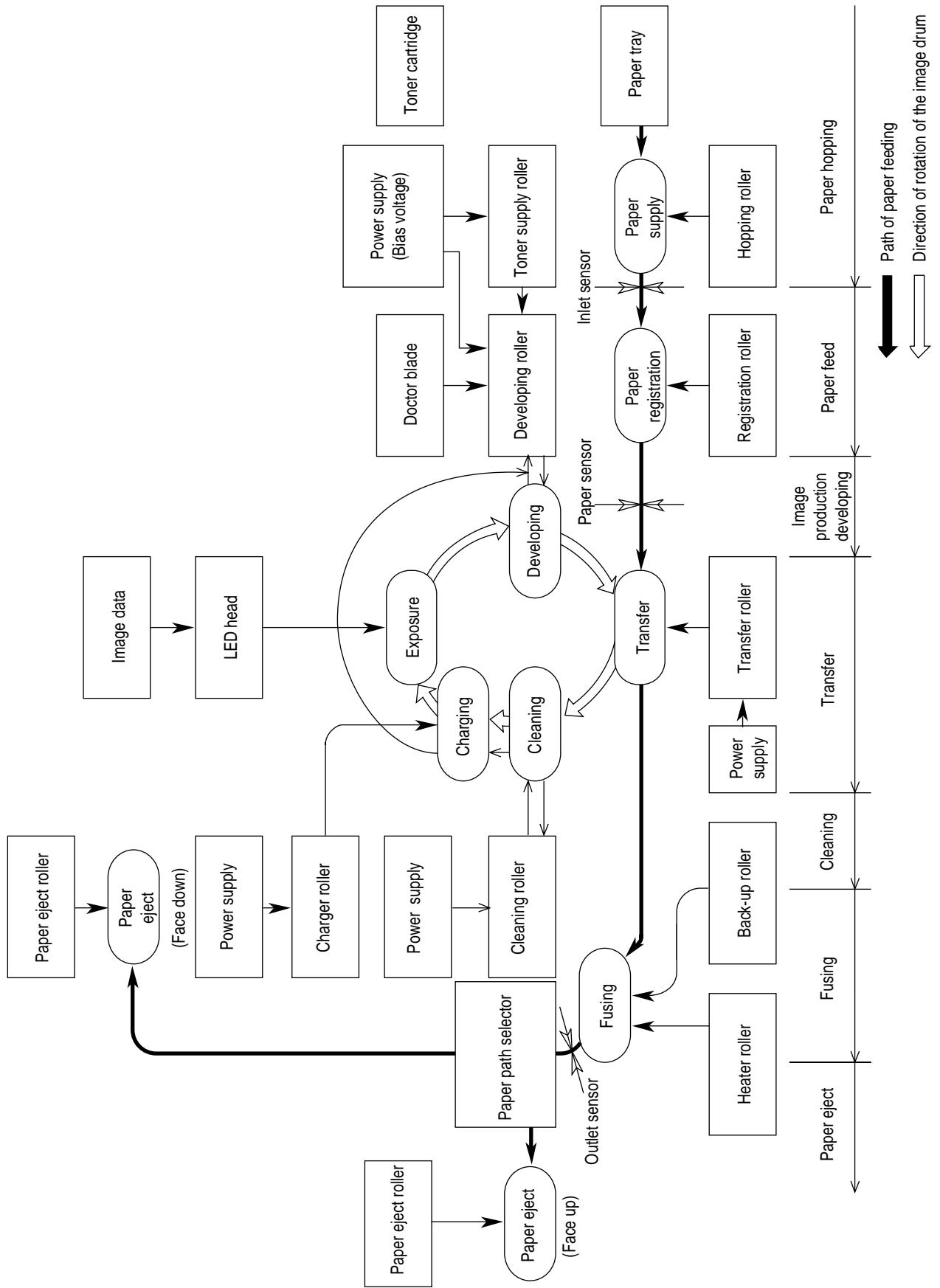

Figure 2-4

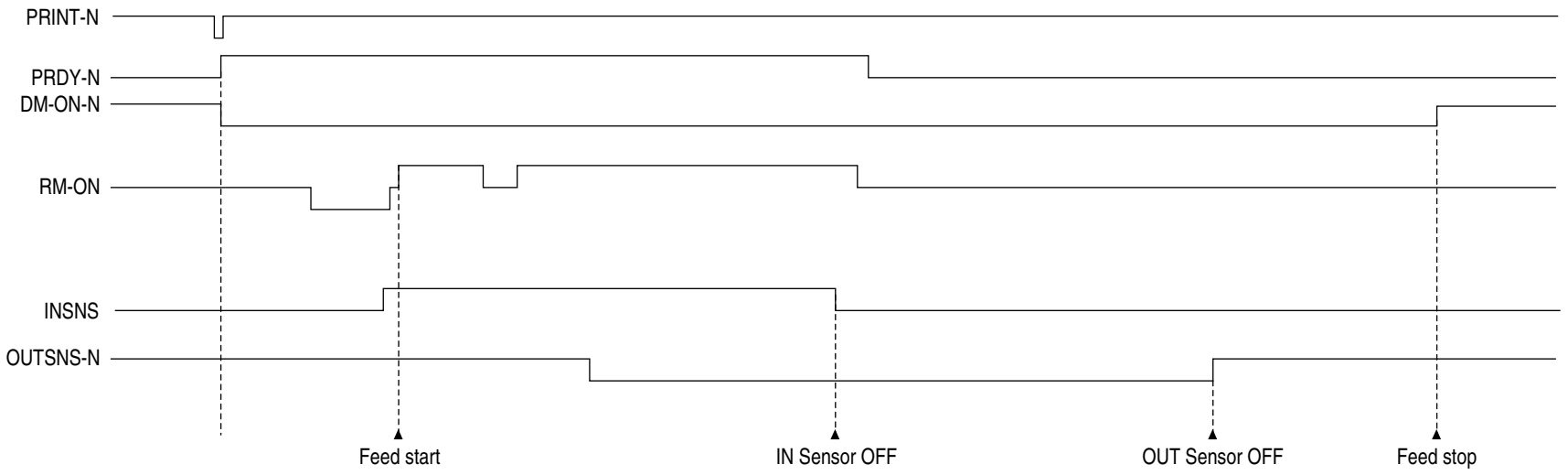
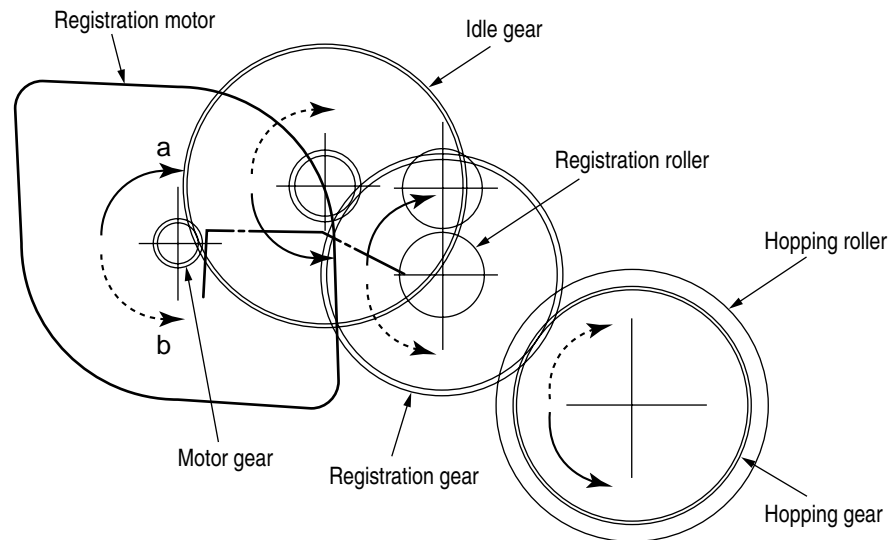

Figure 2-5

2.3.3 Process Operation Descriptions

(1) Hopping and Feeding

Hopping and feeding motions are actuated by a single registration motor in the mechanism as shown below:



The registration motor turning in direction "a" drives the hopping roller. The registration motor turning in direction "b" drives the registration roller. The registration and hopping gears have one-way bearing, so turning any of these gears in the reverse direction will not transmit the motion to the corresponding roller.

(a) Hopping

- ① For hopping, the registration motor turns in direction "a" (clockwise direction) and drives the hopping roller to advance the paper until the inlet sensor turns on (in this case, the registration gear also turns, but the registration roller is prevented from turning by the one-way bearing).
- ② After inlet sensor is turned on by the paper advance, the paper is further advanced to a predetermined distance until the paper hits the registration roller (the skew of the paper can thus be corrected).

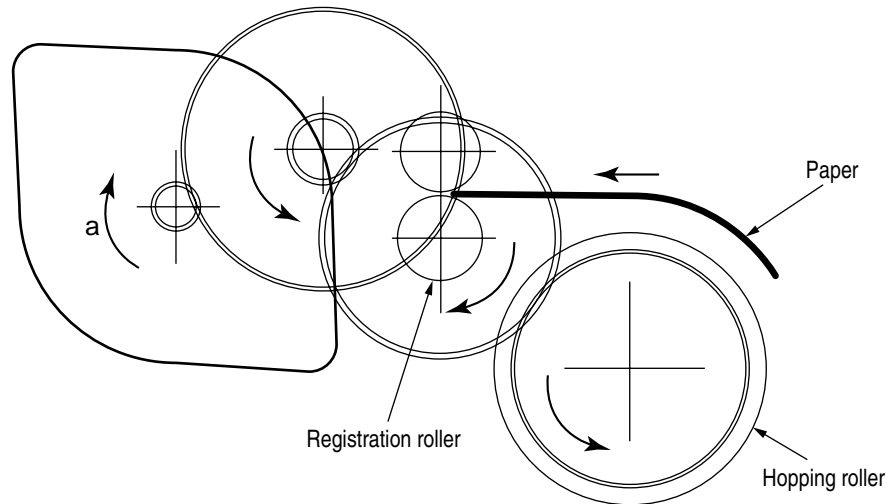

(b) Feeding

- ① When hopping is completed, the registration motor turning in direction "b" (counter-clockwise direction) drives the registration roller to advance the paper (in this case, the hopping gear also turns, but the hopping roller is prevented from turning by the one-way bearing).
- ② The paper is further advanced in synchronization with the print data.

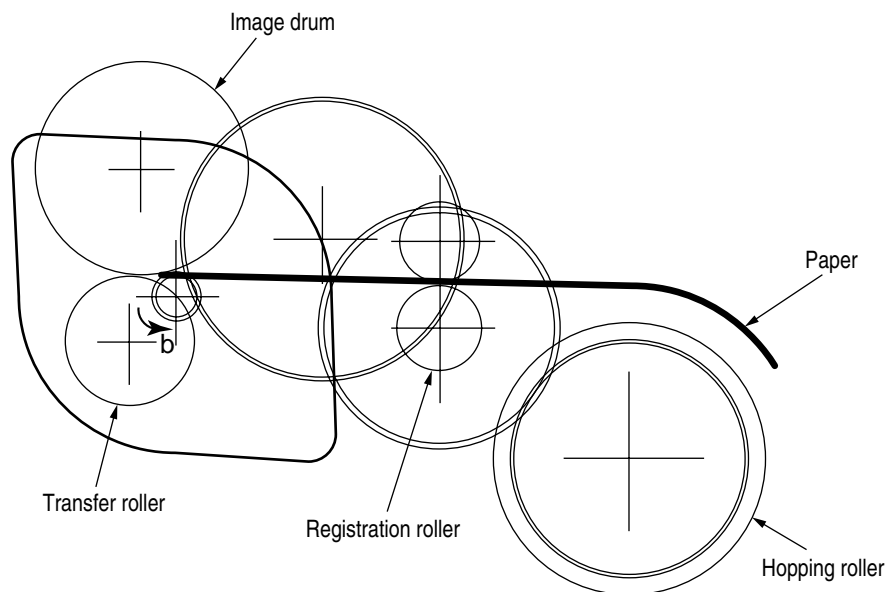

(2) Charging

Charging is actuated by the application of the DC voltage to the charge roller that is in contact with the image drum surface.

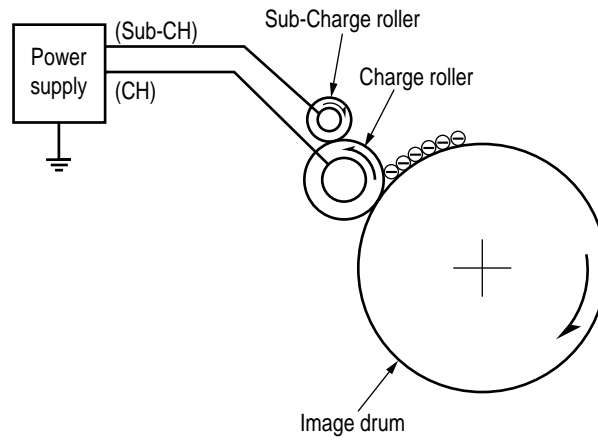

The charge roller is composed of two layers, a conductive layer and a surface protective layer, both having elasticity to secure good contact with the image drum. When the DC voltage applied by the power supply exceeds the threshold value, charging begins. The applied voltage is proportional to the charge potential, with offset of approximately -550V .

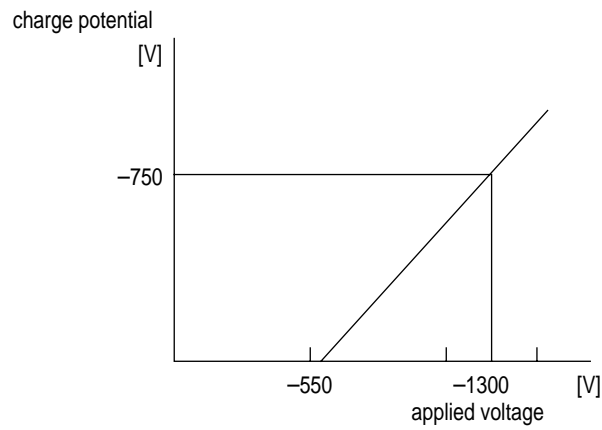

(3) Exposure

Light emitted by the LED head irradiates the image drum surface with a negative charge. The surface potential of the irradiated portion of the image drum drops, forming an electrostatic latent image associated with the image signal.

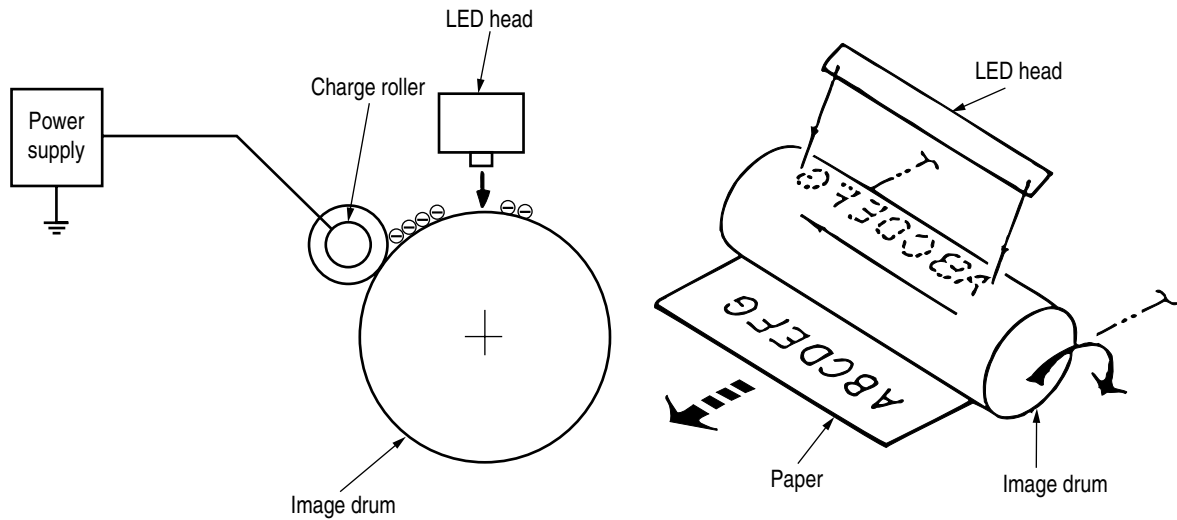

The image drum is coated with an underlayer (UL), a carrier generation layer (CGL), and carrier transfer layer (CTL) on aluminum base. The organic photo conductor layer (OPC), comprising CTL and CGL, is about 20 μm thick.

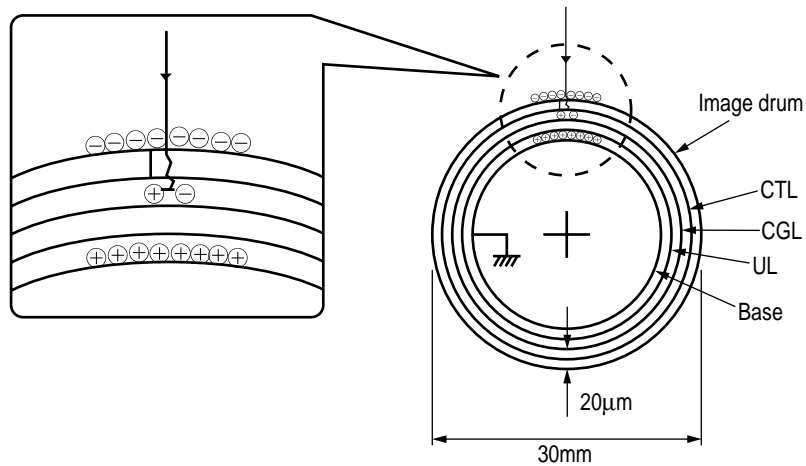

The image roller surface is charged to about -750 V by the contact charge of the charge roller.

When the light from the LED head irradiates the image drum surface, the light energy generates positive and negative carriers in the CGL. The positive carriers are moved to the CTL by an electrical field acting on the image drum. Likewise, the negative carriers flow into the aluminum layer (ground).

The positive carriers moved to the CTL combine with the negative charges on the image drum surface accumulated by the contact charge of the charge roller, lowering the potential on the image drum surface. The resultant drop in the potential of the irradiated portion of the image drum surface forms an electrostatic latent image on it. The irradiated portion of the image drum surface is kept to about -100 V .

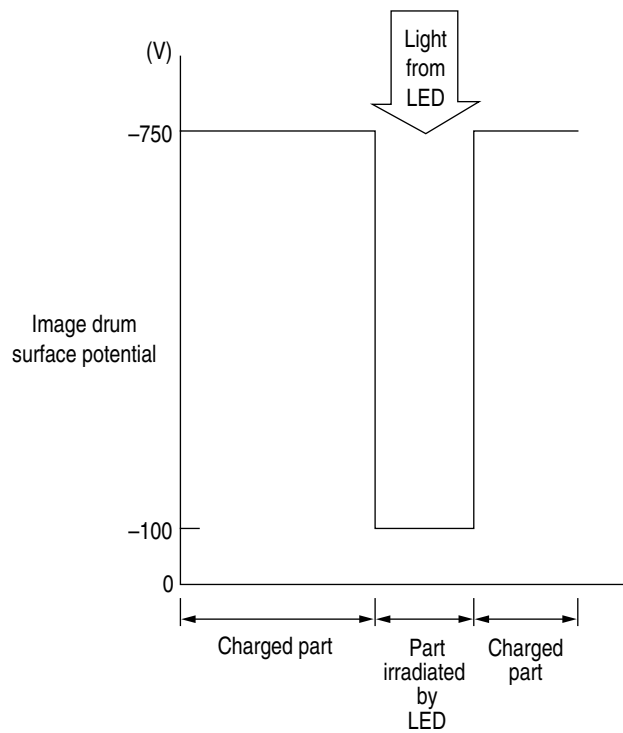

(4) Developing

Toner is attracted to the electrostatic latent image on the image drum surface, converting it into a visible toner image. Developing takes place through the contact between the image drum and the developing roller.

- ① As the toner supply roller rotates while rubbing on the developing roller, a friction charge is generated between the developing roller and the toner, allowing the toner to be attracted to the developing roller (the developing roller surface is charged positive and the toner, negative).

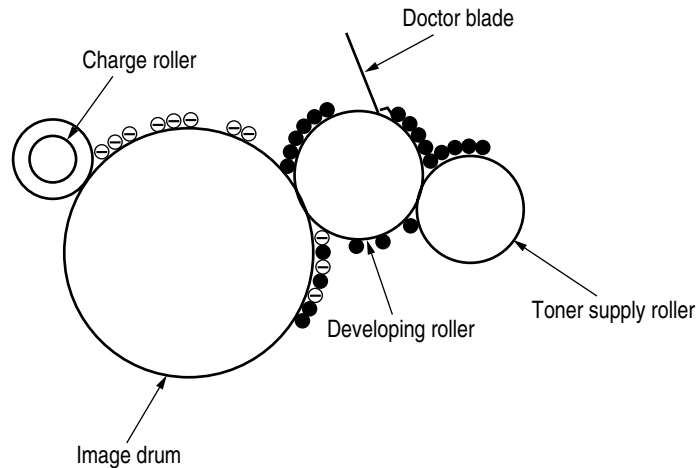

- ② The toner attracted to the developing roller is scraped off by the doctor blade, forming a thin coat of toner on the developing roller surface.
- ③ Toner is attracted to the exposed portion (low-potential part) of the image drum at the contact of the image drum and the developing roller, making the electrostatic latent image visible.

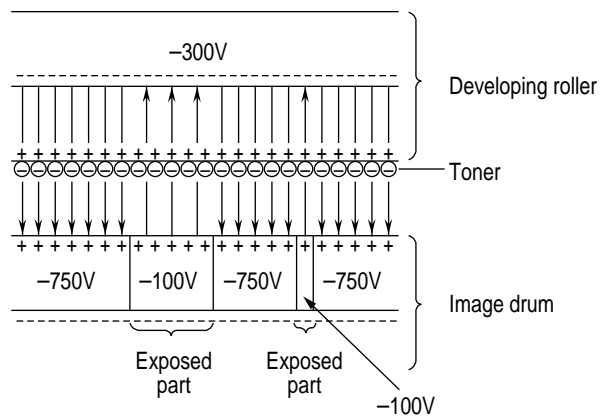

An illustration of activities at the contact point of the image drum surface and the developing roller (arrow marks denote the direction of the electrical field).

Note: The bias voltage required during the developing process is supplied to the toner supply roller and the developing roller, as shown below. -500 VDC is supplied to the toner supply roller, -265 VDC to the developing roller.

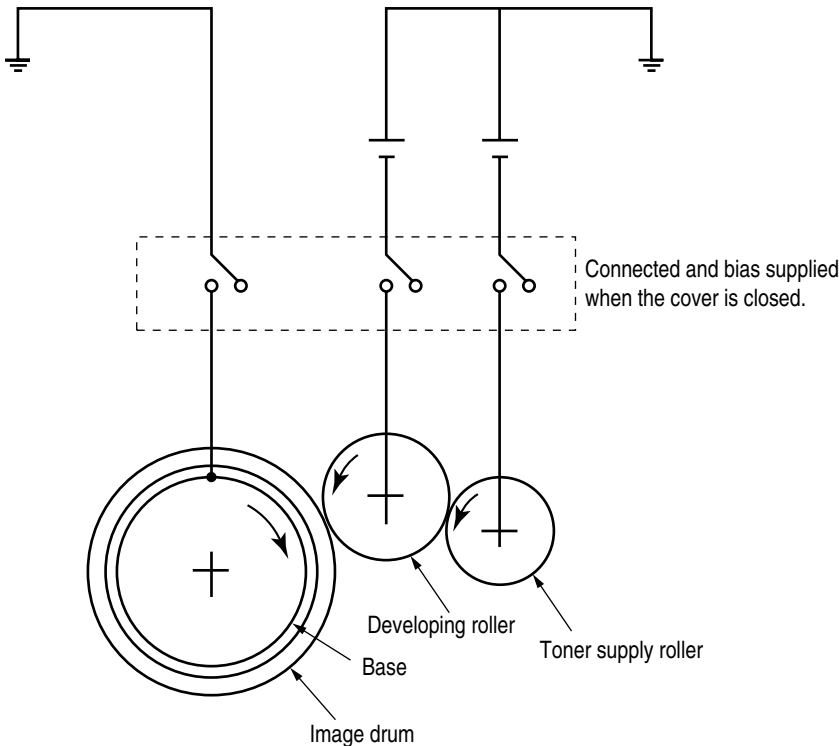

(5) Transfer

The transfer roller is composed of conductive sponge material, and is designed to get the image drum surface and the paper in a close contact.

Paper is placed over the image drum surface, and the positive charge, opposite in polarity to that of the toner, is applied to the paper from the reverse side.

The application of a high positive voltage from the power supply to the transfer roller causes the positive charge inducement on the transfer roller surface, transferring the charge to the paper as it contacts the transfer roller. The toner with negative charge is attracted to the image drum surface, and it is transferred to the upper side of the paper due to the positive charge on the reverse side of the paper.

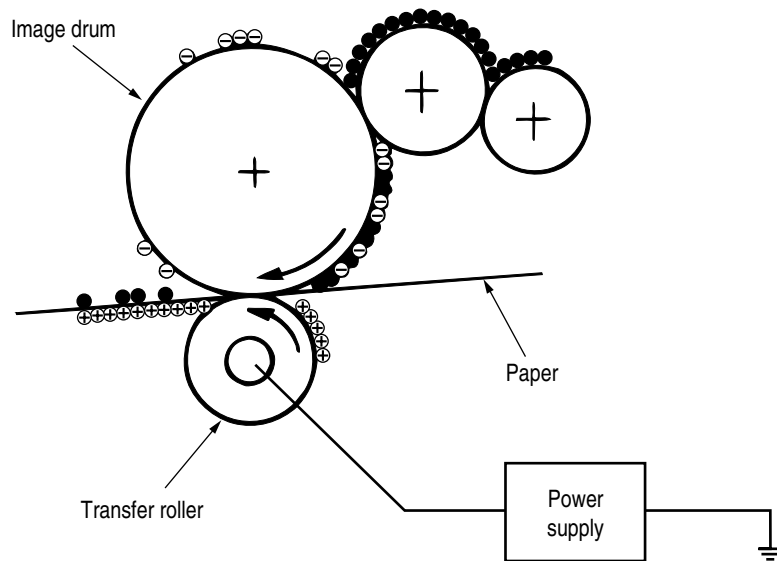

(6) Fusing

When the transfer is completed, the toner image is fused to the paper by heat and pressure as the paper with unfused toner image passes between the heater roller and the back-up roller. The heater roller with Teflon coating incorporates a 550W heater (Halogen lamp), which generates heat.

A thermistor which is in contact with the heater roller regulates the temperature of the heater roller to a designated temperature in the menu, depending on the thickness of the paper (tray 1&2: light=175~185°C, medium light=180~190°C, medium=185~195°C, medium heavy and heavy=195~205°C/manual feeding and power envelope feeder: light=165~180°C, medium light=170~185°C, medium=175~190°C, medium heavy=180~195°C, heavy=190~205°C, transparency = 170~185°C). A safety thermostat cuts voltage supply to the heater off by opening the thermostat in the event of abnormal temperature rises.

The back-up roller is held under a pressure of 3.76 kg applied by the pressure spring on each side.

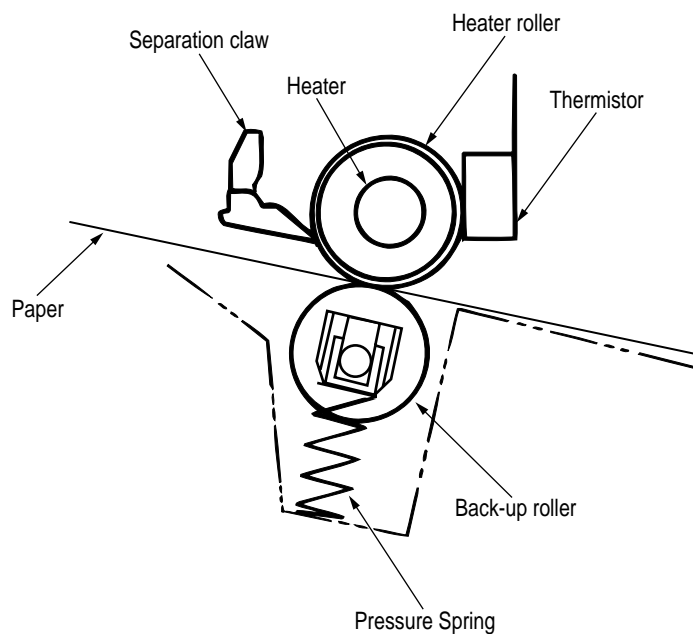

(7) Cleaning

When the transfer is completed, the residual toner left on the image drum is attracted to the cleaning roller temporarily by static electricity, and the image drum surface is cleaned.

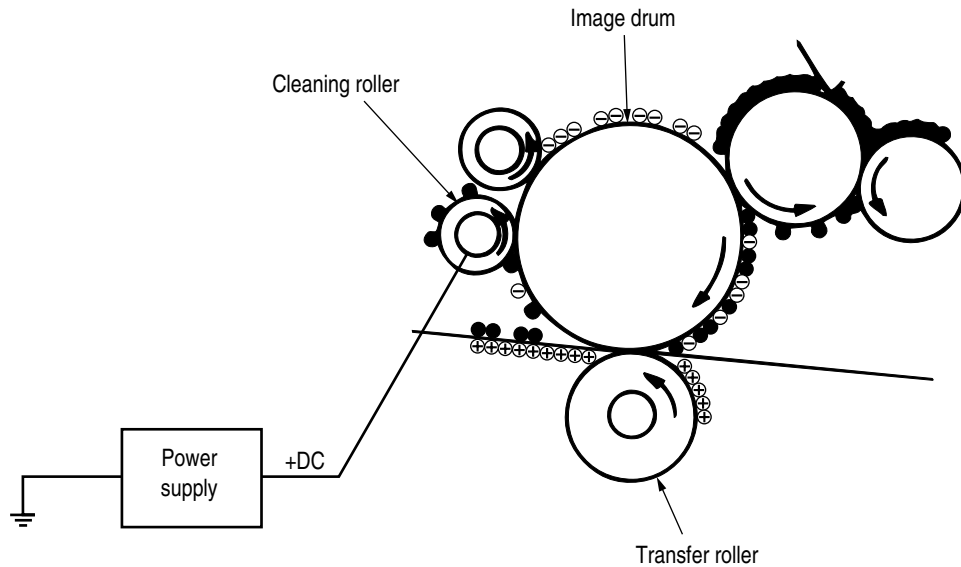

(8) Cleaning of rollers

The charge, transfer and cleaning rollers are cleaned for the following cases:

- Warming up when the power is turned on.
- Warming up after the opening and closing of the cover.
- When the number of sheets accumulated reaches 14 or more.
- When the printout operation ends.

Changes in bias voltage applied to each roller move the attaching toner off the roller to the image drum and return it to the developer.

2.4 Paper Jam Detection

The paper jam detection function monitors the paper condition when the power is turned on and during printing. When any of the following conditions arises, this function interrupts the printing process. If any of the following errors is encountered, printing can be recovered by removing the jammed paper (by opening the upper cover, removing the jammed paper and closing the upper cover).

Error	Cause of error
Paper input jam	<ul style="list-style-type: none"> The paper is in contact with the inlet sensor when the power is turned on. After hopping operation is attempted three times, the leading edge of the paper does not reach the inlet sensor.
Paper feed jam	<ul style="list-style-type: none"> The paper is in contact with the paper sensor when the power is turned on. The leading edge of the paper does not reach the paper sensor within a predetermined feeding distance since the paper has reached the inlet sensor. The trailing edge of the paper does not pass over the paper sensor within a predetermined feeding distance after the same has passed over the inlet sensor. The leading edge of paper does not reach the outlet sensor within a predetermined feeding distance after the paper has reached the paper sensor.
Paper exit jam	<ul style="list-style-type: none"> The paper is in contact with the outlet sensor when the power is turned on. The paper does not pass over the outlet sensor within a predetermined feeding distance after the leading edge of the paper has reached the outlet sensor. The paper size check for manual feeding finds that the paper size is free size.
Paper size error	<ul style="list-style-type: none"> The size of the paper is monitored by the inlet sensor 1. The paper is not detected by the inlet sensor 1 within predetermined feeding distance. The inlet sensor 2 detects that the size of the loaded paper is A4 or larger, or smaller than A4. The detected paper size differs from the paper size set by command or menu. The paper size check for manual feeding finds that the paper size is free size.

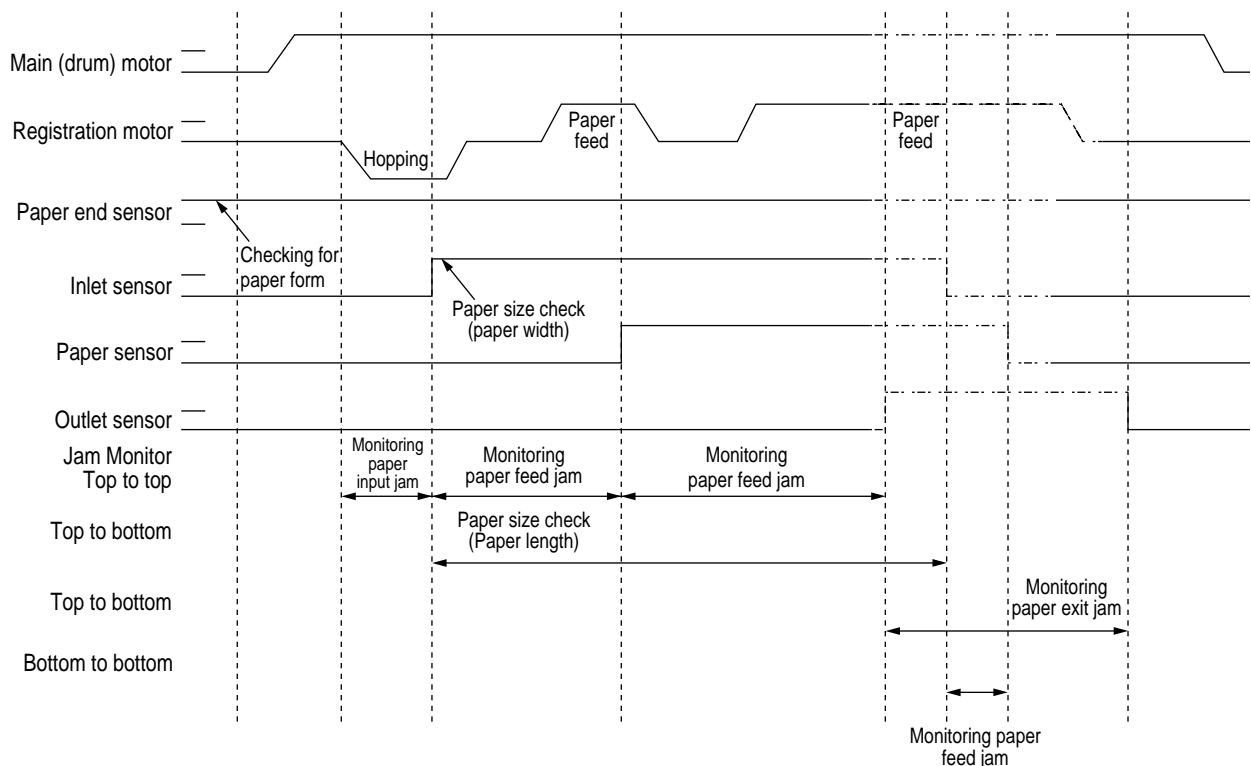

Paper Feed Timing Chart

Paper Feed Check List

Type of error	Monitor		Standard value	Error	
				Plus	Minus
Paper feed error	Hopping start	to In sensor on	72.0	36.0	-
Paper feed jam	In sensor on	to Write sensor on	20.0	68.0	-
Paper feed jam	Write sensor on	to Out sensor on	140.5	25.0	-
Paper size error	In sensor on	to In sensor off	Depends on the paper length	45.0	45.0
Paper exit jam	Out sensor on	to Out sensor off	Depends on the paper length	45.0	45.0
Paper feed jam	In sensor off	to Write sensor off	22.2	22.0	-

Unit : mm

Note: Hyphen "-" in the table represents "not checked."

Paper Length List

Type	Paper length	Check range	
		Min	Max
A4	297.0	252.0	342.0
A5	210.0	165.0	255.0
B5	257.0	212.0	302.0
LETTER	279.4	234.4	324.4
LEGAL 13	330.2	285.2	375.2
LEGAL 14	355.6	310.6	400.6
EXEC	266.7	221.7	311.7
A6	148.0	103.0	193.0
Monarch	190.5	145.5	235.5
COM-9	225.4	180.4	270.4
COM-10	241.3	196.3	286.3
DL	220.0	175.0	265.0
C5	229.0	184.0	274.0
Free	110.1~355.6	65.0	400.6

Unit : mm

2.5 Cover Open

When the stacker cover is opened, the cover open microswitch on the power supply/sensor board is turned off to cut +5V supply to the high voltage power supply circuit. This results in the interruption of all high-voltage outputs. At the same time, the CVOPN signal is sent to the main control board to notify that the microswitch is off, and the main control board carries out the cover open process.

2.6 Toner Low Detection

- **Device**
The Toner Low Detection device consists of a stirring gear which rotates at a constant rate, a stirring bar and a magnet on the stirring bar. The stirring bar rotation is driven by the link to the gouged portion in the stirring gear.

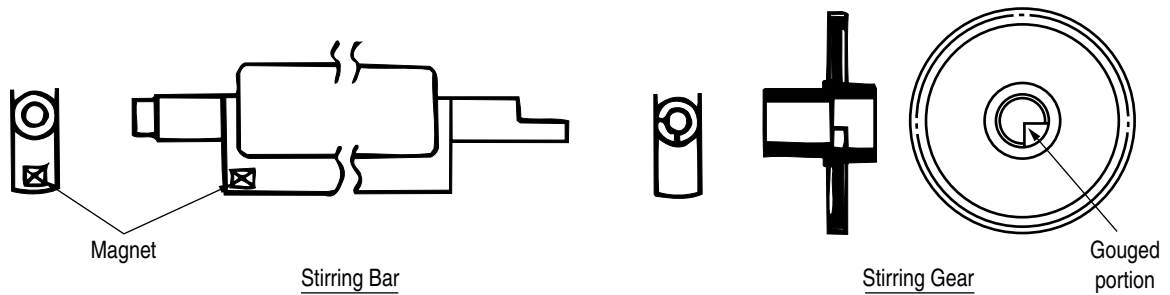

- **Operation**
Toner Low is detected by monitoring the time interval of the encounter of the magnet set on the sensor plate and the magnet on the stirring bar.

Operation during Toner Full state

- The stirring bar rotates due to the mechanical transmission of energy originating from the interlocking with the stirring gear.
- Even when the magnet on the stirring bar reaches the maximum height, the stirring bar is pushed by the stirring gear, since the other side is being dipped in the toner.

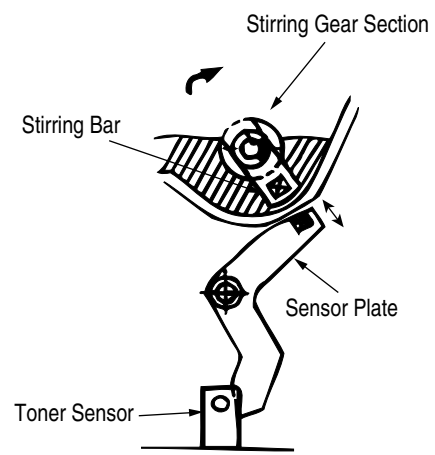

Operation during Toner Low state

- When the stirring bar reaches the maximum height, it falls to the minimum height due to its own weight, since there is no resistance provided by the toner on the other side. Because of this, the time interval during which it is in encounter with the magnet of the sensor plate becomes longer. By monitoring this time interval, Toner Low state can be detected.

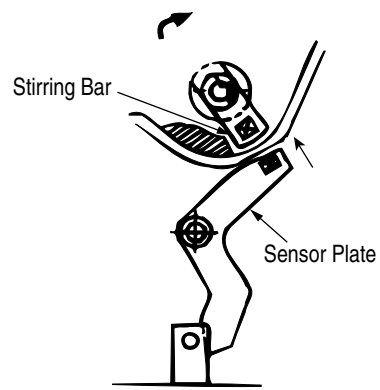

TONER FULL state

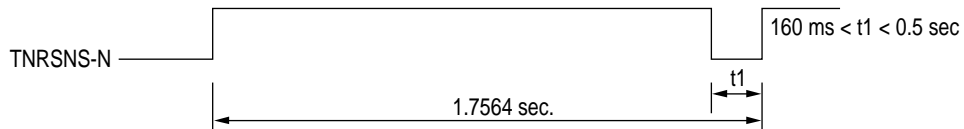

TONER LOW state

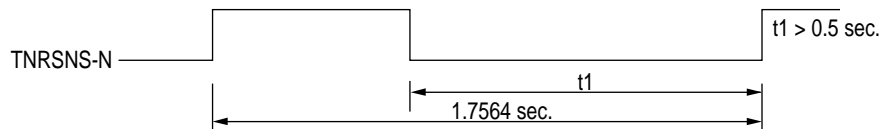

- When the Toner Low state is detected 2 times consecutively, Toner Low is established.
- When the Toner Full state is detected 2 times consecutively, Toner Low is cancelled.
- When there is no change with the toner sensor for 2 cycles ($1.7564 \text{ sec.} \times 2$) or more, then the Toner Sensor Alarm is activated.
- The toner sensor is not monitored while the main (drum) motor is in a halt.

3. PARTS REPLACEMENT

This section explains the procedures for replacement of parts, assemblies, and units in the field. Only the disassembly procedures are explained here. For reassembly, reverse the disassembly procedure.

3.1 Precautions for Parts Replacement

- (1) Before starting to replace parts, remove the AC cord and interface cable.
 - (a) Remove the AC cord in the following sequence:
 - i) Turn off ("o") the power switch of the printer
 - ii) Disconnect the AC inlet plug of the AC cord from the AC receptacle.
 - iii) Disconnect the AC cord and interface cable from the printer.
 - (b) Reconnect the printer in the following procedure.
 - i) Connect the AC cord and interface cable to the printer.
 - ii) Connect the AC inlet plug to the AC receptacle.
 - iii) Turn on ("I") the power switch of the printer.

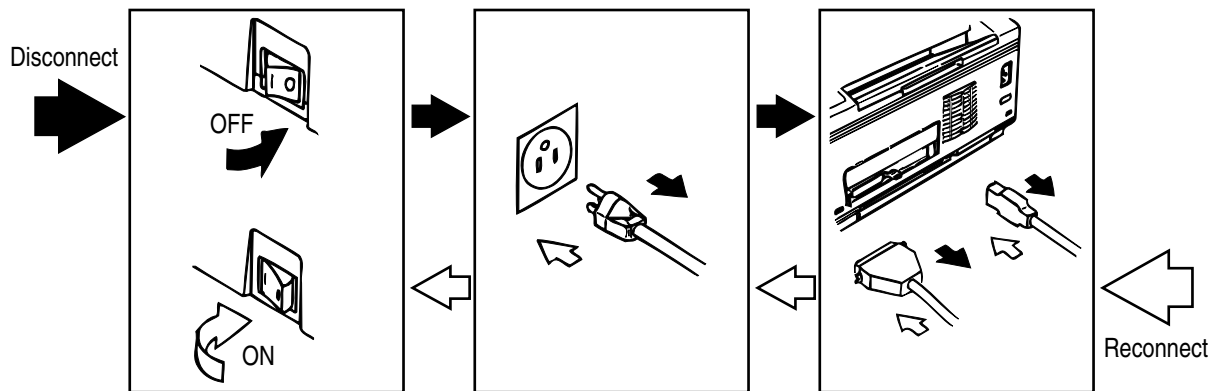





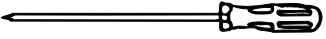

- (2) Do not disassemble the printer as long as it is operating normally.
- (3) Do not remove parts which do not have to be touched; try to keep the disassembly to a minimum.
- (4) Use specified service tools.
- (5) When disassembling, follow the laid out sequences. Parts may be damaged if these sequences are not followed.
- (6) Since screws, collars and other small parts are likely to be lost, they should temporarily be attached to the original positions during disassembly.
- (7) When handling IC's such as microprocessors, ROMs and RAMs, or circuit boards, do not wear gloves that are likely to generate static electricity.
- (8) Do not place printed circuit boards directly on the equipment or floor.

[Service Tools]

The tools required for field replacement of printed circuit boards, assemblies and units are listed in Table 3-1.

Table 3-1 Service Tools

No.	Service Tools	Q' ty	Application	Remarks
1	 No. 1-100 Philips screwdriver	1	2~2.5 mm screws	
2	 No. 2-100 Philips screwdriver	1	3~5 mm screws	
3	 No. 3-100 screwdriver	1		
4	 No. 5-200 screwdriver	1		
5	 Digital multimeter	1		
6	 Pliers	1		
7	 Handy cleaner	1		
8	 LED Head cleaner	1	Cleans LED head	

3.2 Parts Layout

This section explains the layout of main components of the equipment.

[Lower base unit]

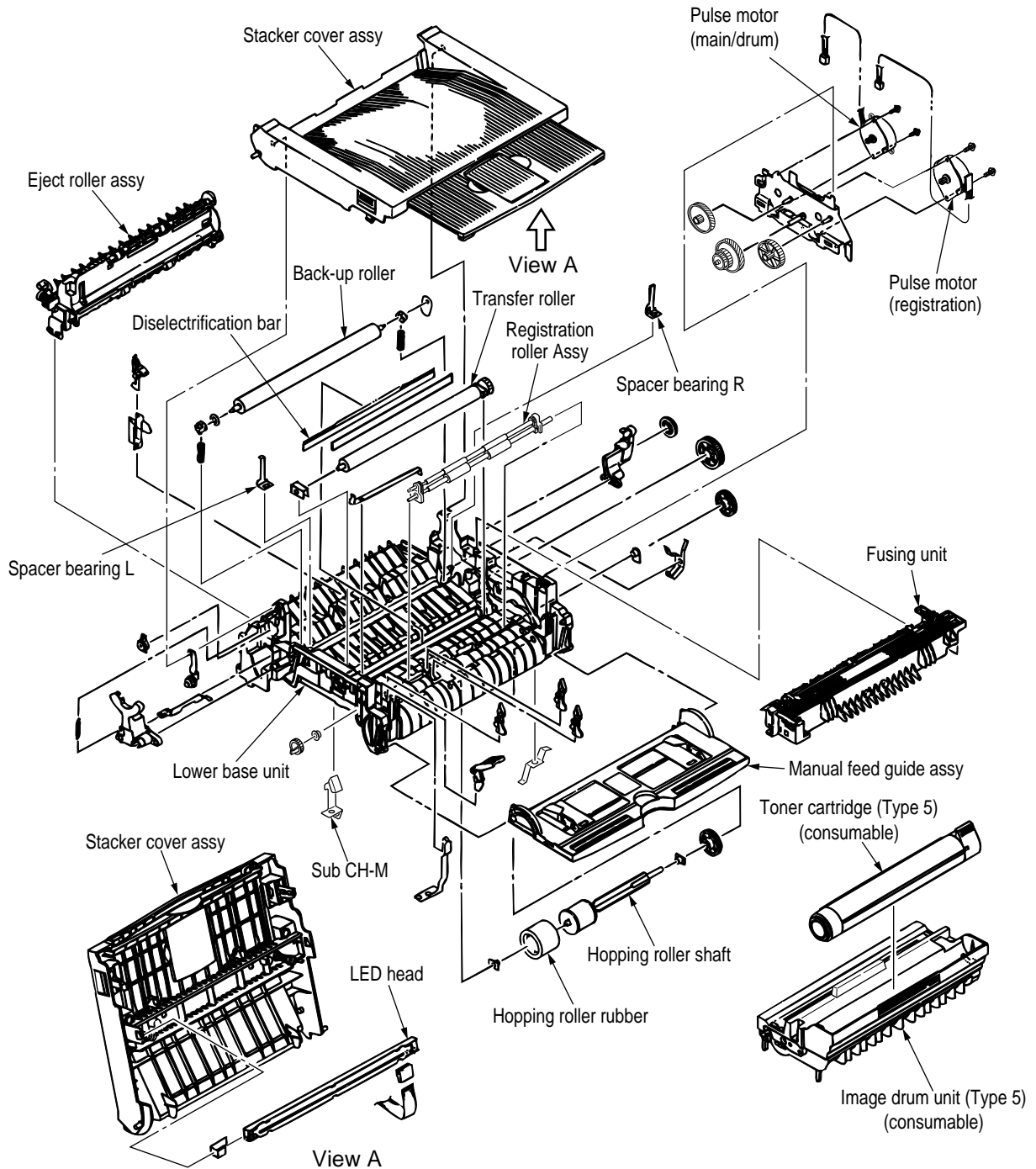

Figure 3-1

[Upper cover unit]

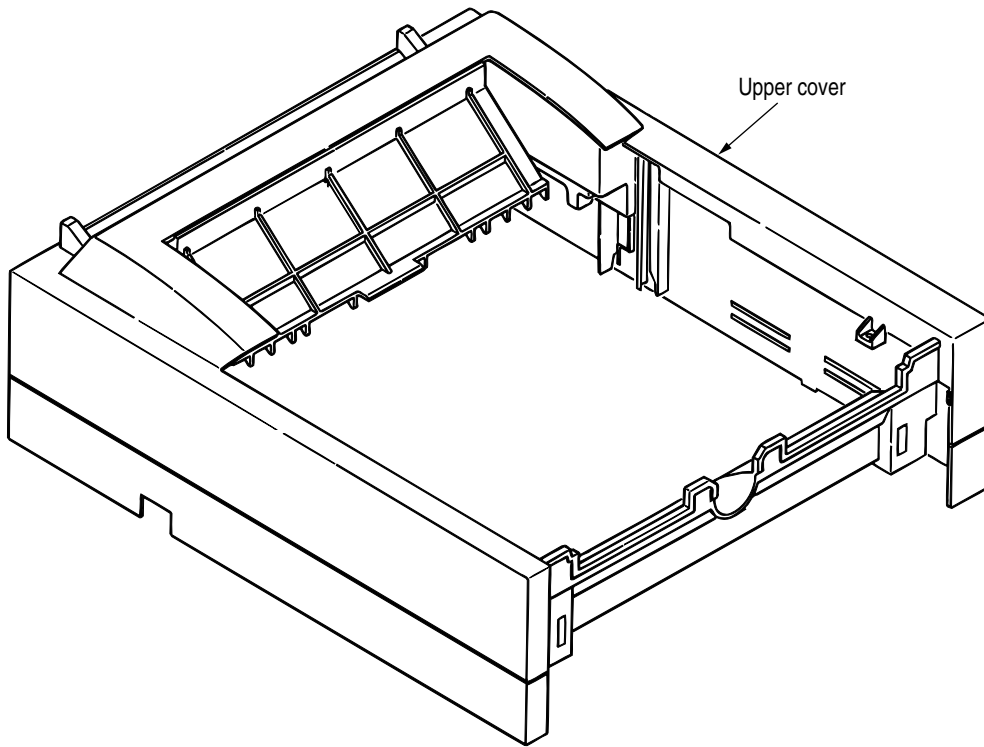

Figure 3-2

[Base unit]

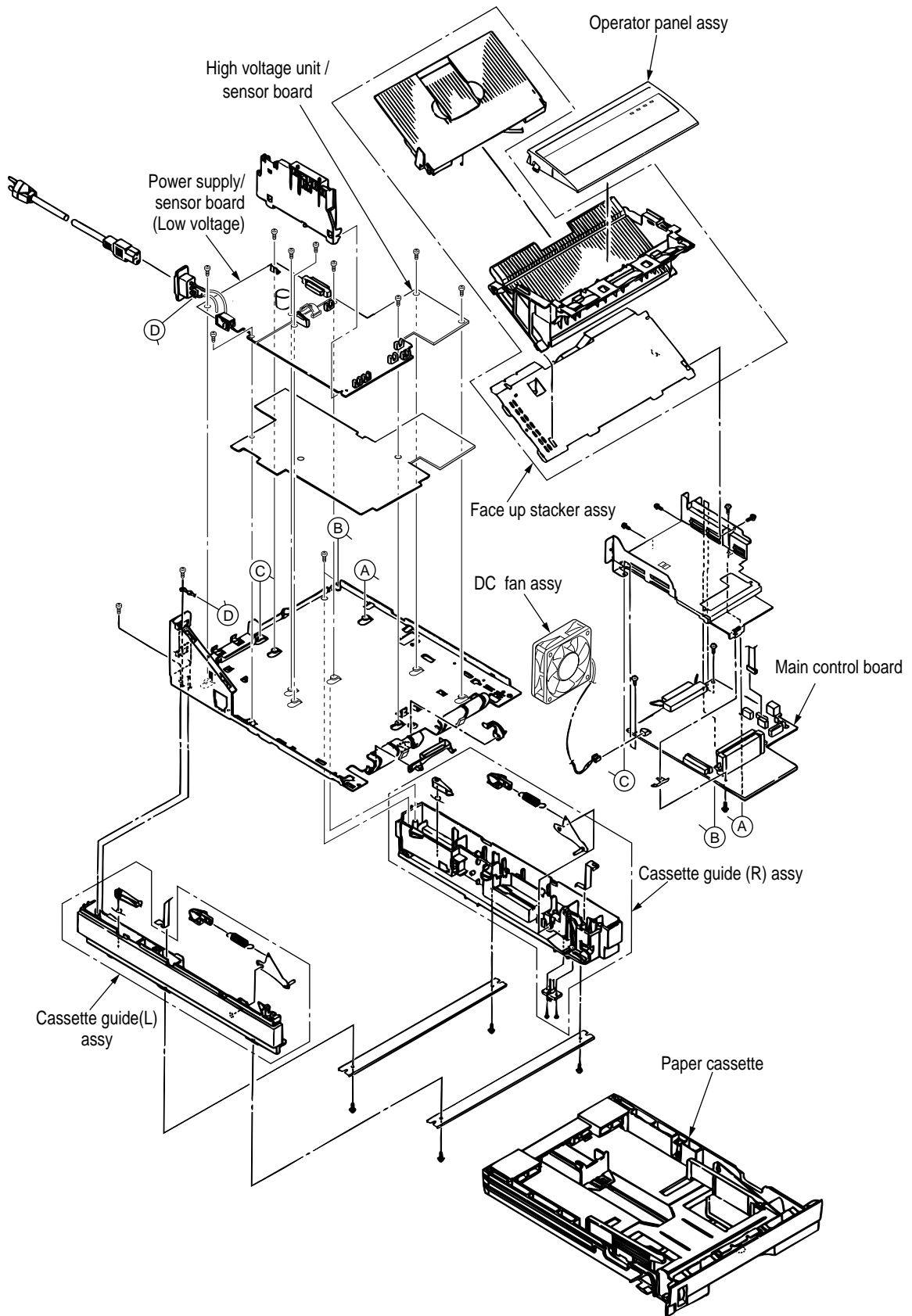
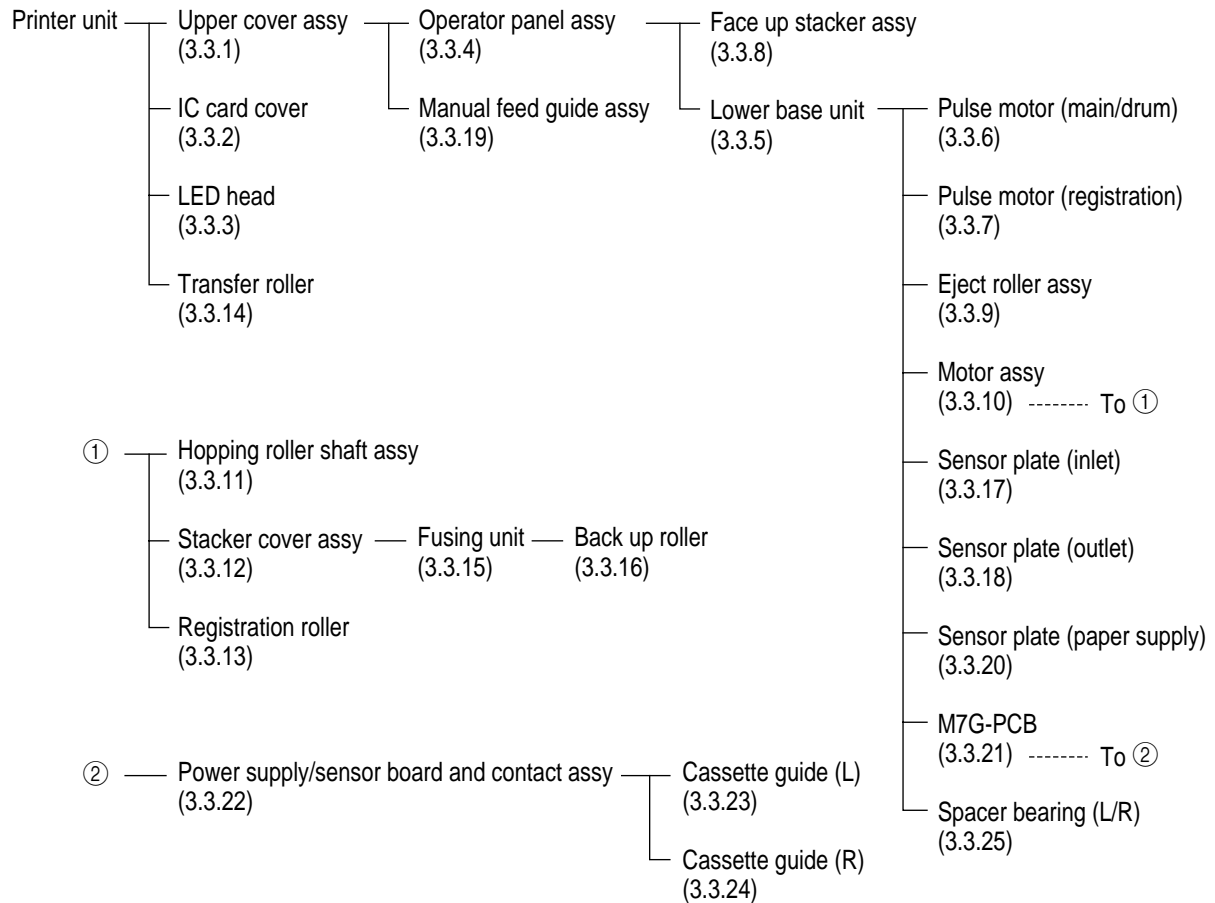

Figure 3-3

3.3 How to Change Parts

This section explains how to change parts and assemblies listed in the disassembly diagram below.

In the parts replacement procedure, those parts marked with the part number inside ● with white letters are RSPL parts.



3.3.1 Upper Cover Assy

- (1) With the power switch turned off, unplug the AC power cord from the outlet.
- (2) Disconnect the interface cable ①.
- (3) Press the knobs ② on left and right sides and open the stacker cover Assy ③.
- (4) Take out the image drum unit ④.
- (5) Remove two screws ⑤, and open the manual feed guide Assy ⑥. Lift the front side of the upper cover ⑦ up and unlock the latches at two locations on the back side. Lift and remove the upper cover Assy ⑦.

Notes : 1. When removing or reinstalling the upper cover, be careful not to get the motor cables tangled or caught.

2. When reinstalling the screws ⑤, be sure to direct the screws into preexisting threads.

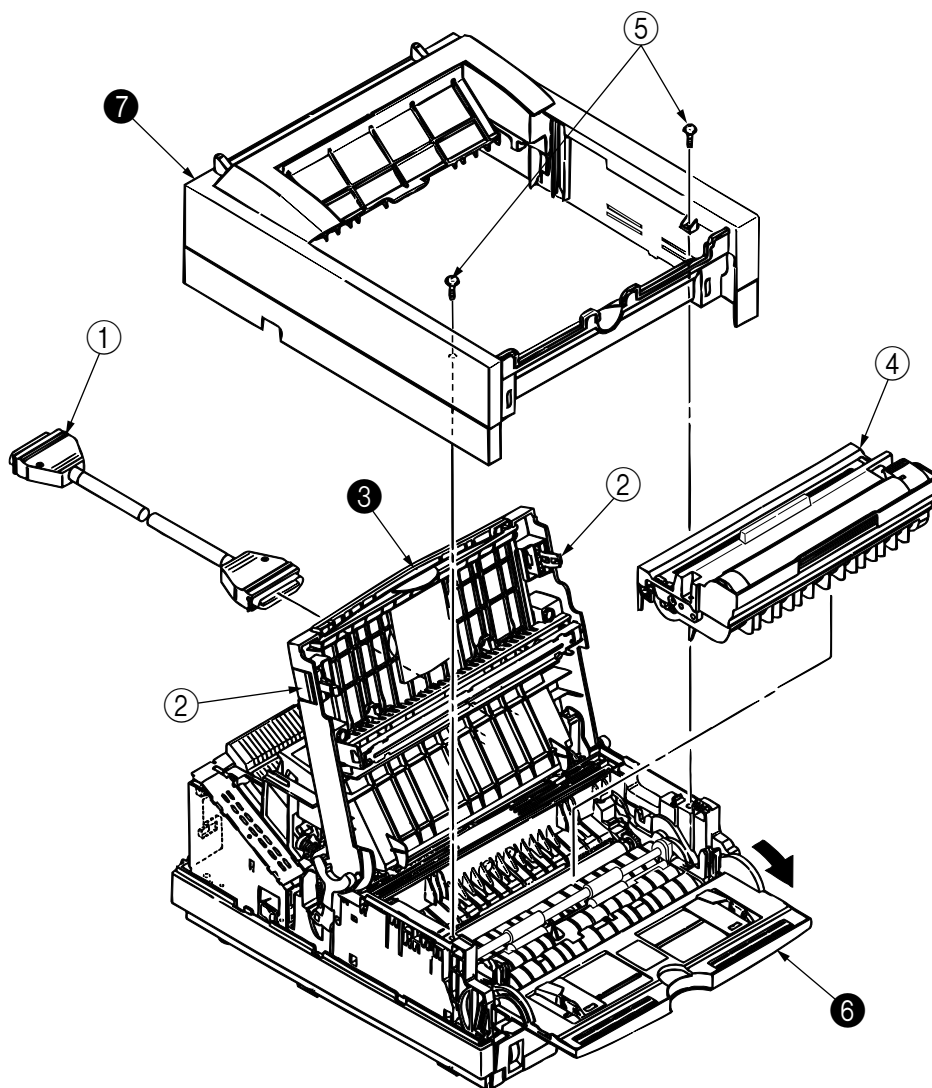

3.3.2 IC Card Cover

- (1) Open the IC card cover ①, press it from both sides at the hinges in the directions of arrows shown below and remove it.

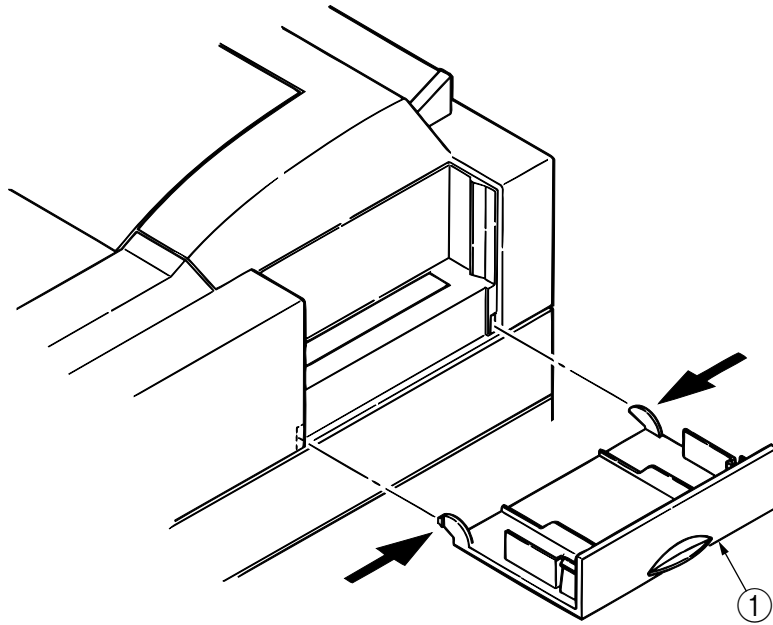

3.3.3 LED Head

- (1) Press the knobs on left and right sides and open the stacker cover assy ❶.
- (2) Open the hook section on the left side of the stacker cover and remove the LED head ❷.

- Note:**
- Be sure not to touch directly or push on the SLA part of the LED head.
 - Do not remove the LED cable ❸ from the connector.
 - Remove connector ❹ and cable ❸ together as an assembly from the LED head.
 - After mounting the new LED head and reinstalling the cable, set drive time of the LED head according to the marking on the LED head (see 4.2.1).

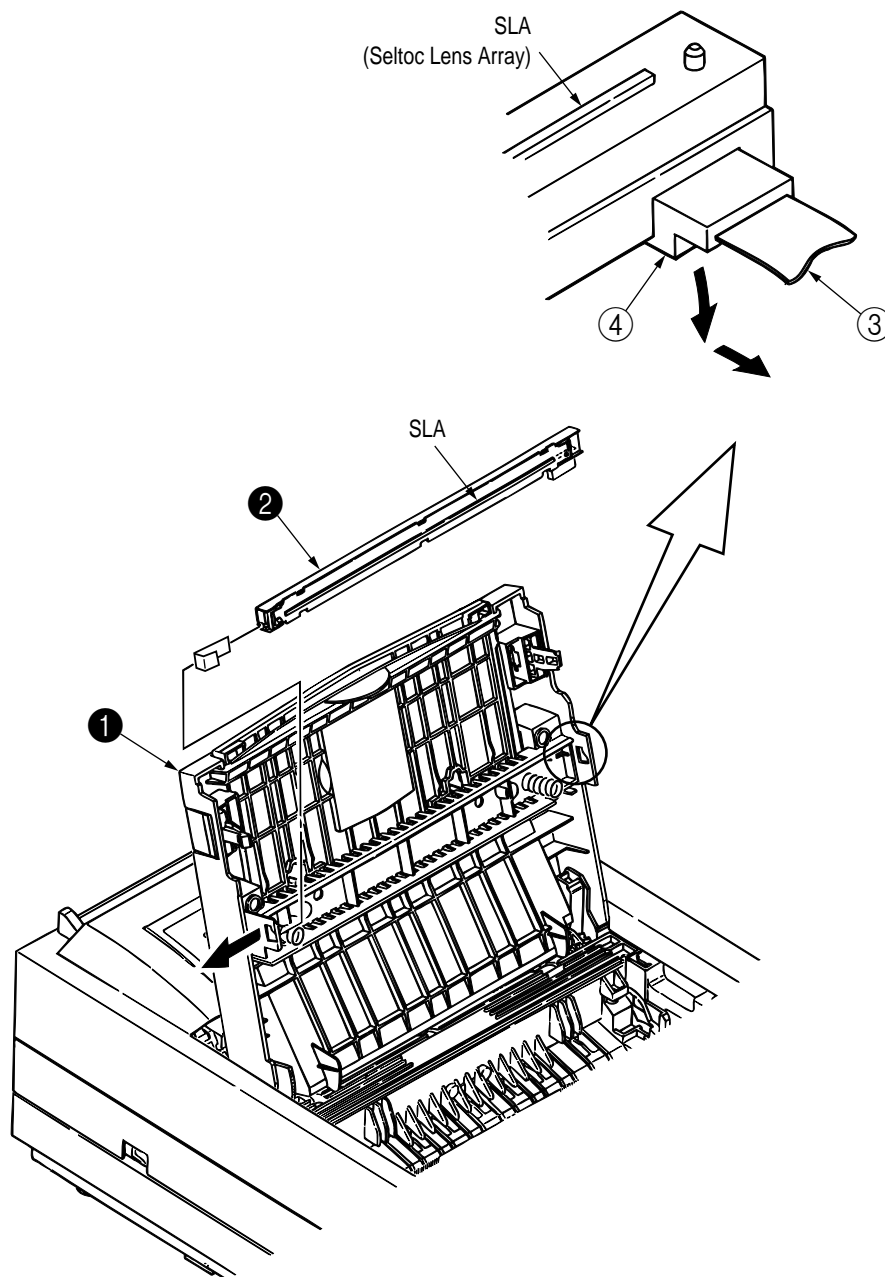

3.3.4 Operator Panel Assy

- (1) Unlock two latches on the upper cover from the rear side, lift the operator panel assy ❶ from the back and remove it.
- (2) Remove the Sumi card (operator panel) ❷ from the connector (CN1) ❸.

Note : You can remove the operator panel assy while the upper cover installed on the unit. However, it is much easier to remove the panel assy after removal of upper cover.

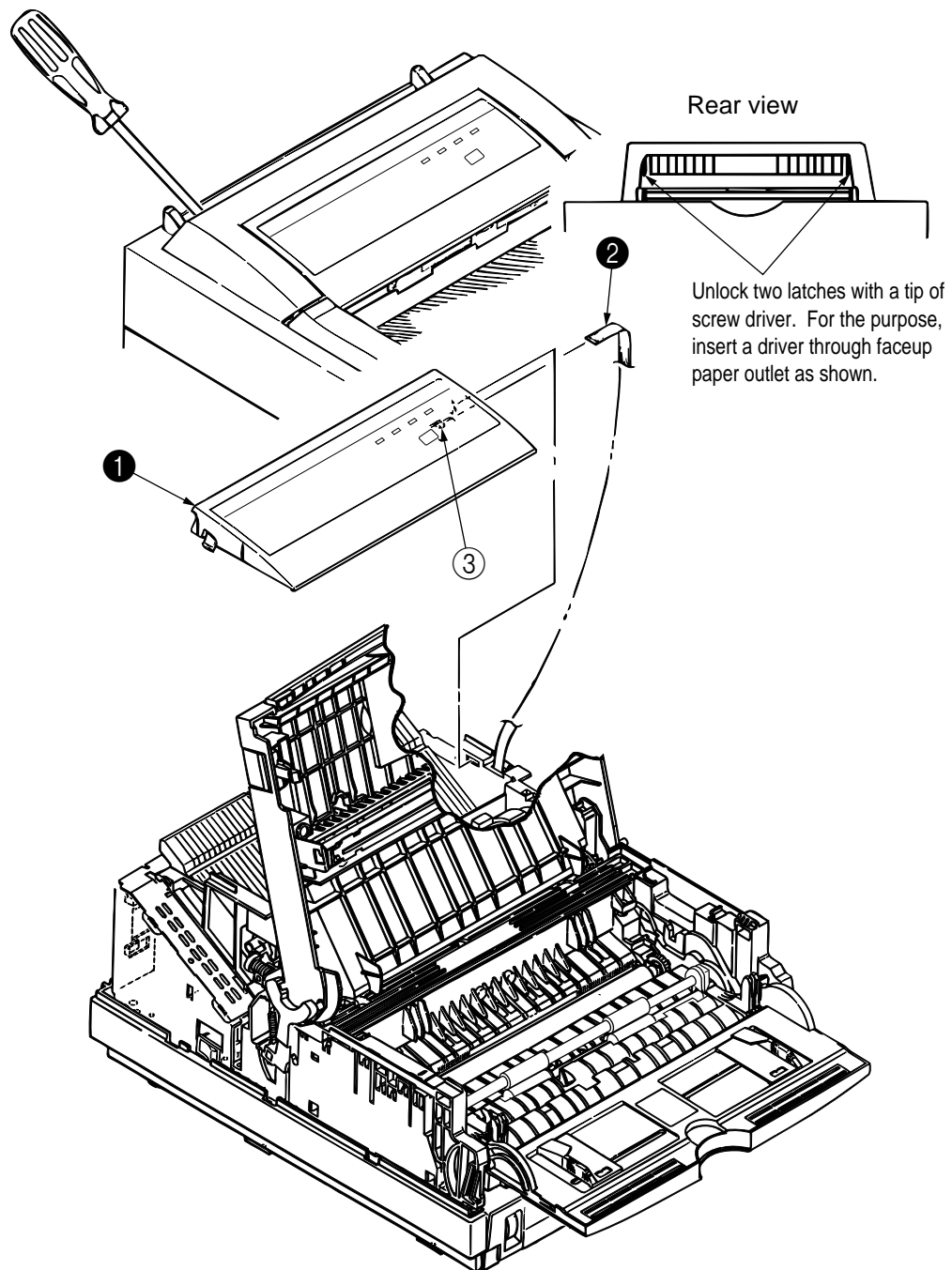

3.3.5 Lower Base Unit

- (1) Remove the upper cover assy (see 3.3.1).
- (2) Remove the operator panel assy (see 3.3.4).
- (3) Remove the face up stacker assy (see 3.3.8).
- (4) Remove the connecting cables ② and ③ of the pulse motors from the connectors (DM, RM) of the M7G-PCB ①.
- (5) Remove the LED head cables ④ from the connectors (HEAD1).
- (6) Open the manual feed guide assy, remove six screws ⑦, then remove the lower base unit ⑥.

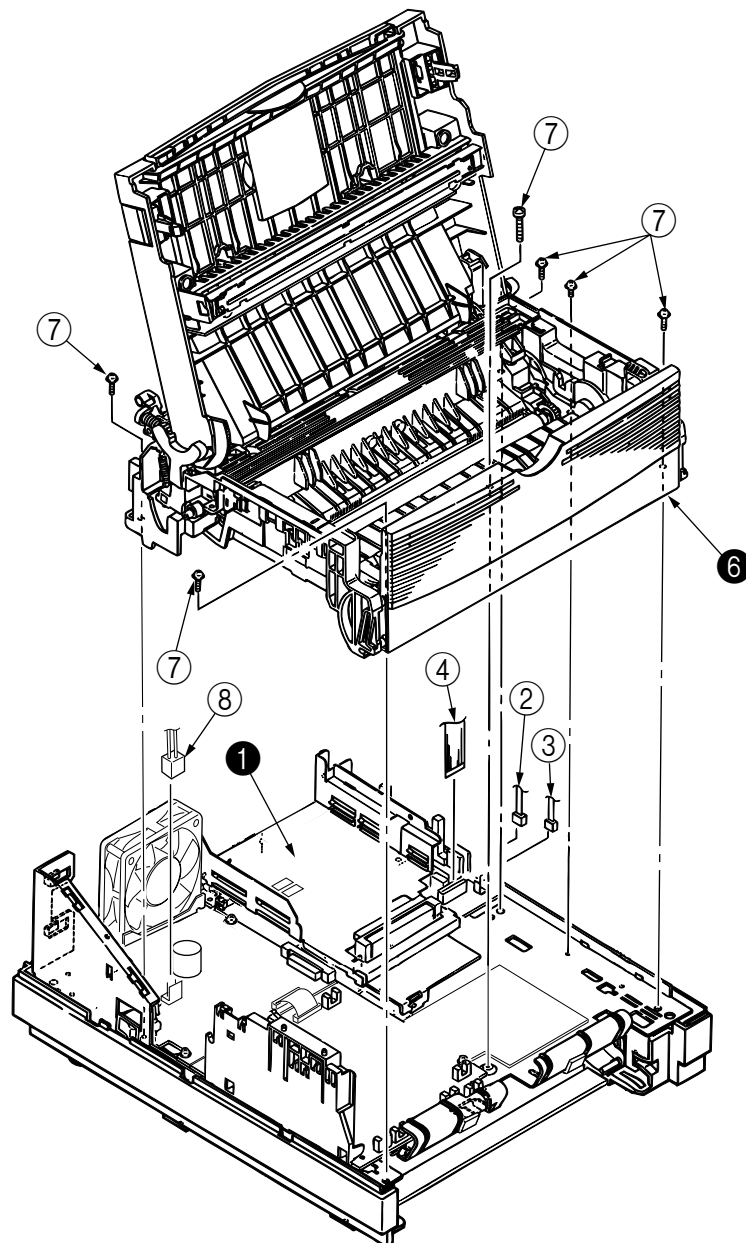

3.3.6 Pulse Motor (Main/Drum)

- (1) Remove the upper cover assy (see 3.3.1).
- (2) Remove the lower base unit (see 3.3.5).
- (3) Remove two screws ① and remove the pulse motor (main/drum) ② from the motor bracket ③.

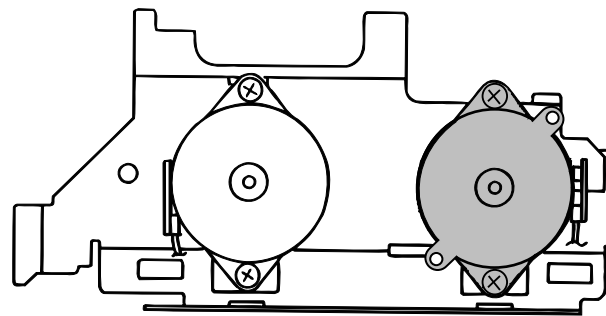

View A

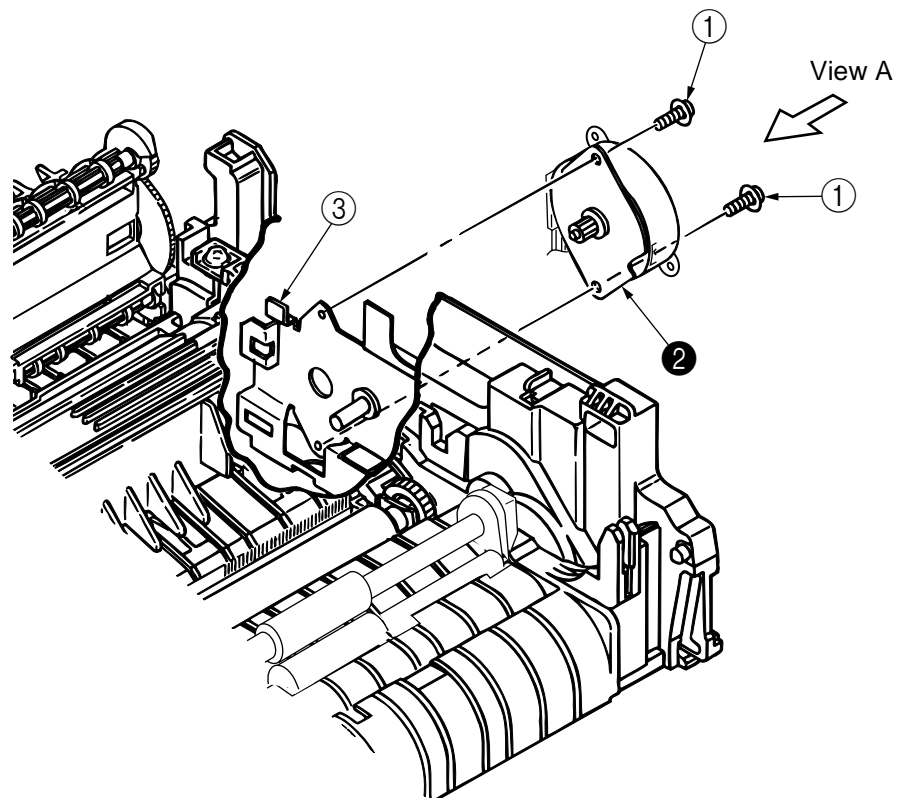

3.3.7 Pulse Motor (Registration)

- (1) Remove the upper cover assy (see 3.3.1).
- (2) Remove the lower base unit (see 3.3.5).
- (3) Remove two screws ① and remove the pulse motor (registration) ② from the motor bracket ③.

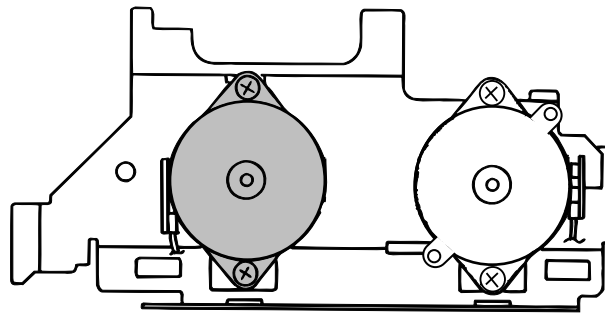

View A

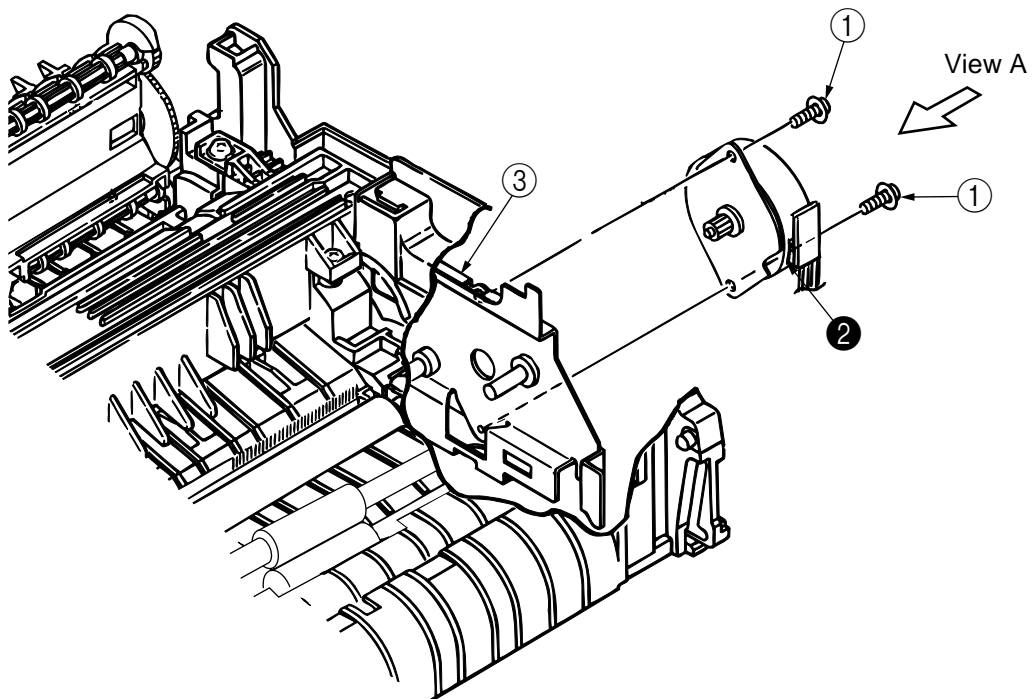

3.3.8 Face Up Stacker Assy

- (1) Remove the upper cover assy (see 3.3.1).
- (2) Remove the operator panel assy (see 3.3.4).
- (3) Remove the screw ① and remove the Sumi card (operator panel cable) ② off the latch section of face up stacker ④. Remove both the shield plate ③ and face up stacker ④ together.
- (4) Unlock the latches at two locations, and remove the face up stacker ④.

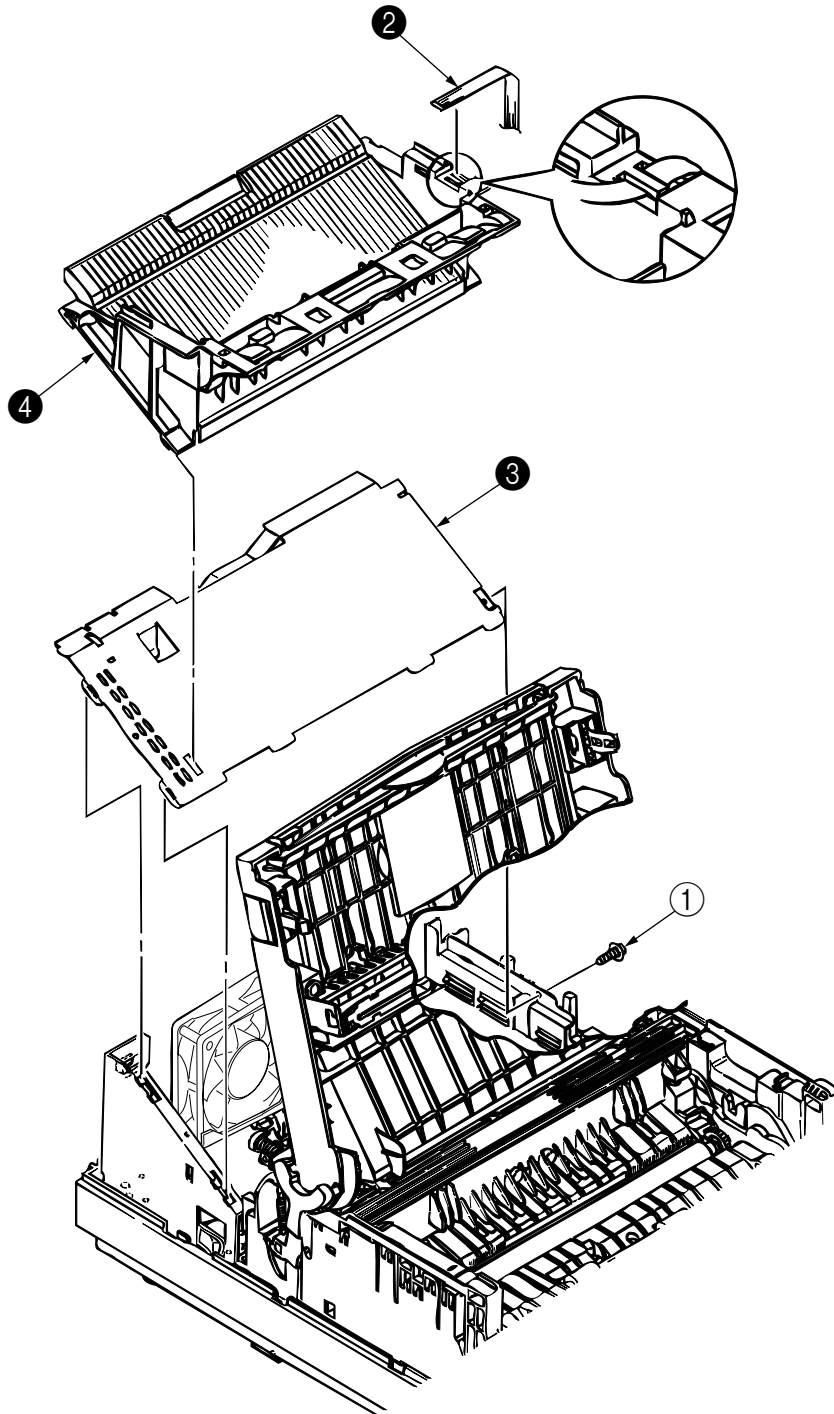

3.3.9 Eject Roller Assy

- (1) Remove the upper cover assy (see 3.3.1).
- (2) Remove the operator panel assy (see 3.3.4).
- (3) Remove the face up stacker assy (see 3.3.8).
- (4) Remove the lower base unit (see 3.3.5).
- (5) Disengage the eject roller assy ❶ from the lower base ❷ by pressing the latch section of the eject roller assy ❶ in the direction of the arrow shown below, and remove the eject roller assy ❶.

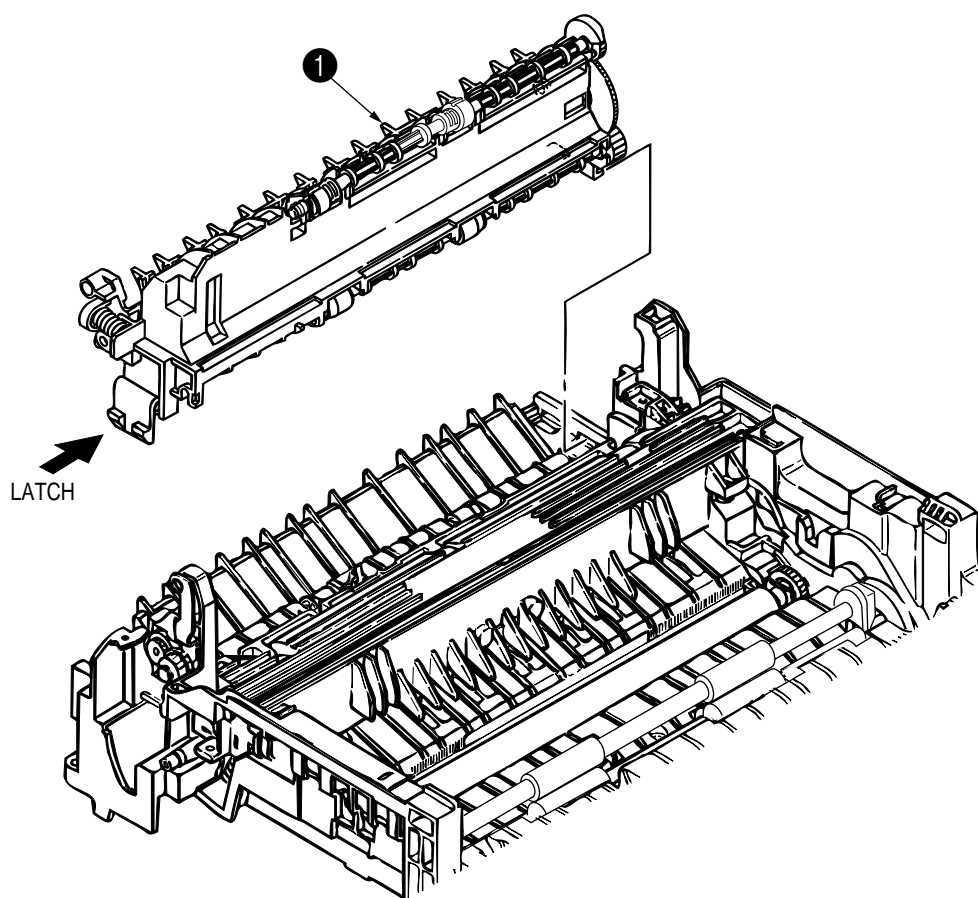

3.3.10 Motor Assy

- (1) Remove the upper cover assy (see 3.3.1).
- (2) Remove the operator panel assy (see 3.3.4).
- (3) Remove the face up stacker assy (see 3.3.8).
- (4) Remove the lower base unit (see 3.3.5).
- (5) Stand the lower base unit on its side as shown, and unlock two latches, then remove the motor assy ①.

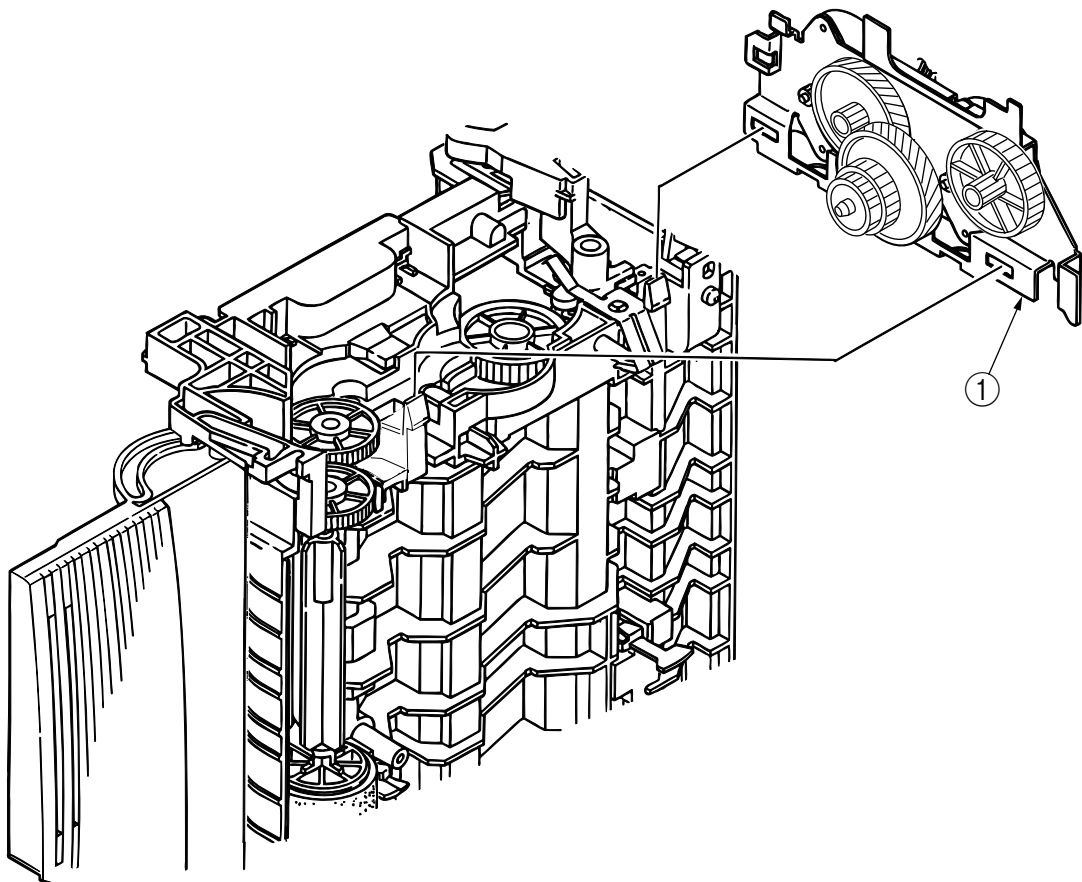

3.3.11 Hopping Roller Shaft Assy

- (1) Remove the upper cover (see 3.3.1).
- (2) Remove the operator panel assy (see 3.3.4).
- (3) Remove the face up stacker assy (see 3.3.8).
- (4) Remove the lower base unit (see 3.3.5).
- (5) Remove the motor assy (see 3.3.10).
- (6) With the lower base unit ① standing on its side, remove the one-way clutch gear ② and the bearing (A) ③.
- (7) Remove the hopping roller shaft assy ④ (the bearing (B) ⑤ comes off, so be careful not to lose it).

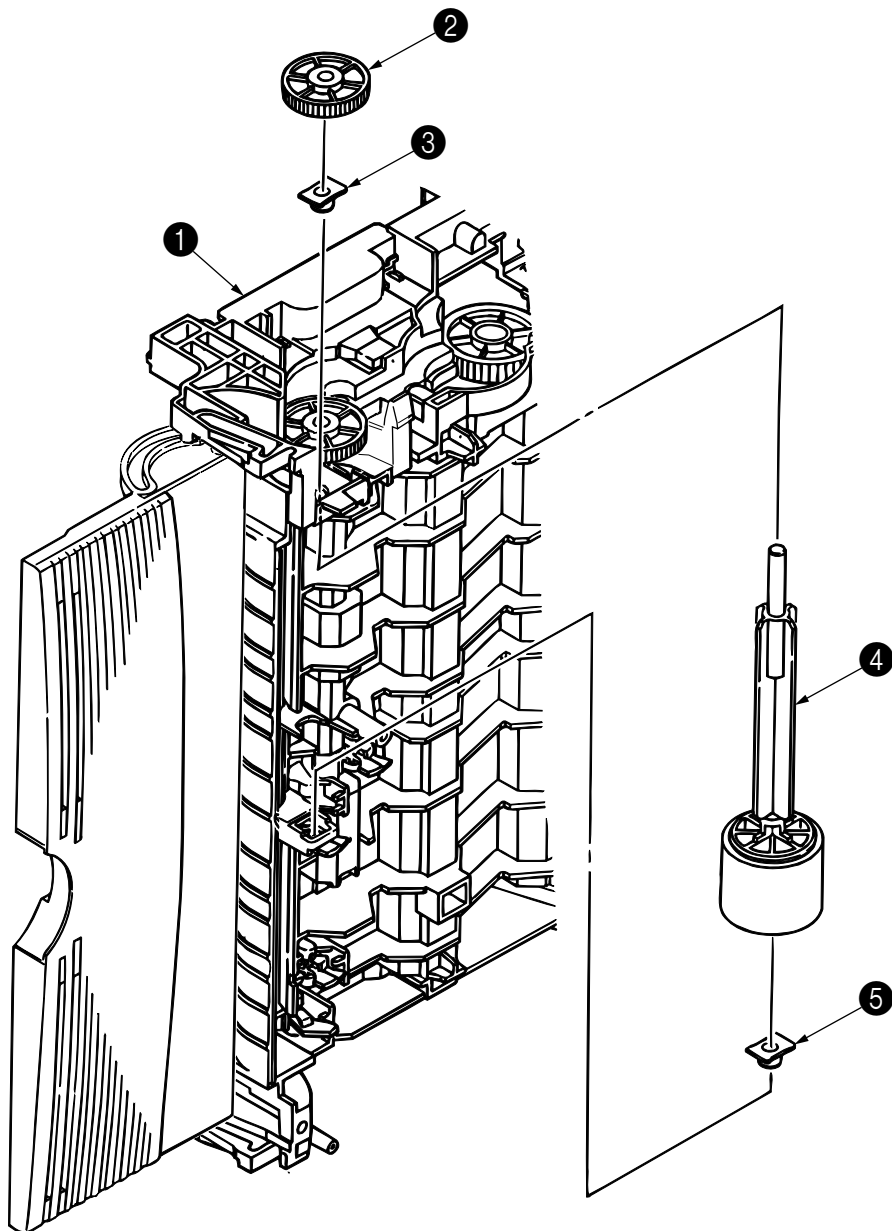

3.3.12 Stacker Cover Assy

- (1) Remove the upper cover assy (see 3.3.1).
- (2) Remove the operator panel assy (see 3.3.4).
- (3) Remove the face up stacker assy (see 3.3.8).
- (4) Remove the reset lever R ①.
- (5) Detach the reset spring ② from the lower base unit ③, turn the reset lever L ④ in the direction of arrow ⑤ until it stops, and remove it in the direction of arrow ⑥.
- (6) Unlock two latches of the lower base unit ③, then remove the stacker cover assy ⑤.

Note : When reinstalling the reset lever L ④, fit it onto the guide of the lower base unit ③, turn it in the direction of arrow ⑦ while pressing down the shaft of back up roller, and engage the reset lever L ④.

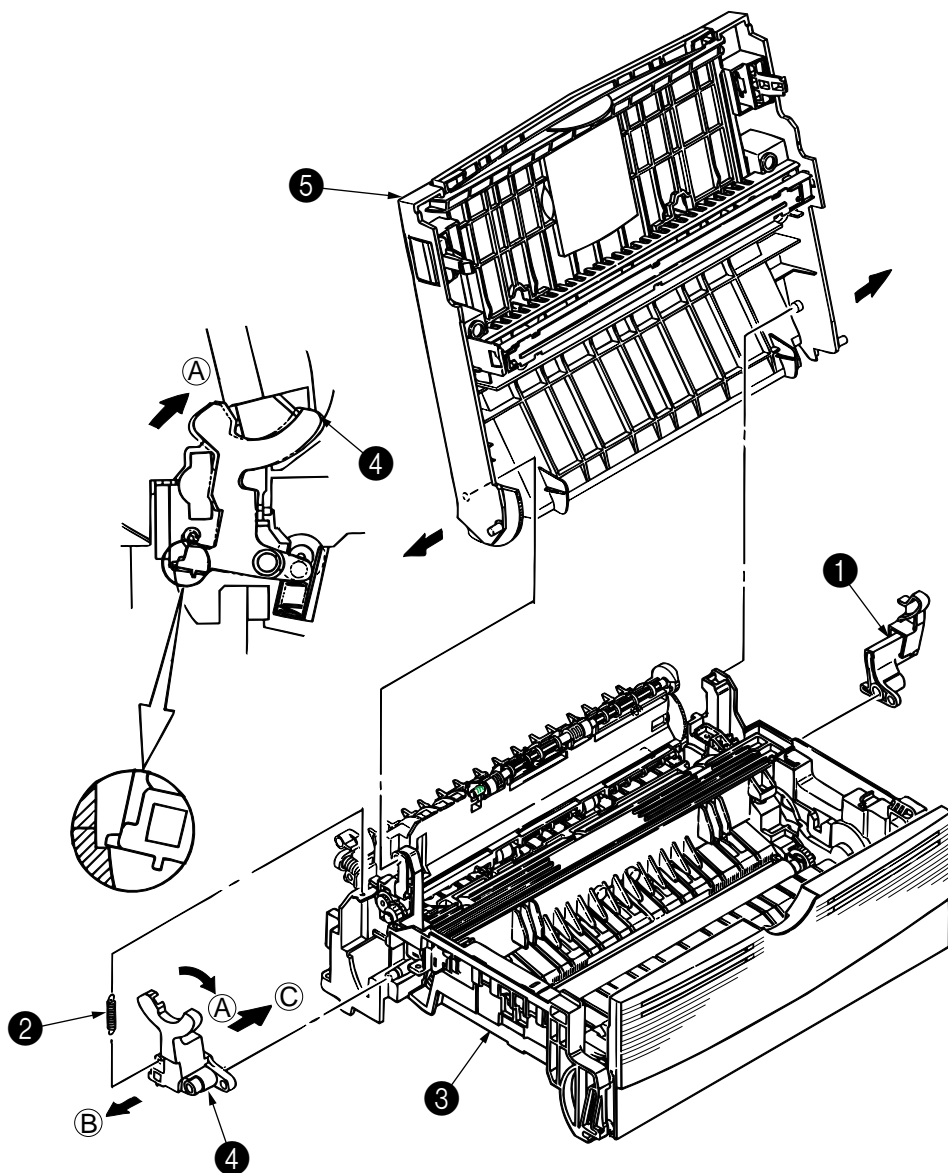

3.3.13 Registration Roller

- (1) Remove the upper cover (see 3.3.1).
- (2) Remove the operator panel assy (see 3.3.3).
- (3) Remove the face up stacker assy (see 3.3.8).
- (4) Remove the lower base unit (see 3.3.5).
- (5) Remove the motor assy (see 3.3.10).
- (6) With the lower base unit standing on its side, remove the one-way clutch gear ① and the bearing ⑨.
- (7) Remove the Registration Gear by unlatching of the Gear ④ .
- (8) Remove the Registration Bearing(L) ③ .
- (9) Press the registration roller Assy ② in the direction of arrow ① and lift up the left side of it, then remove the registration roller Assy ② .
- (10) Pull out the registration roller Assy ② in the direction of arrow ②.
- (11) Remove the pressure roller gear ⑤ by unlockin the lach of the gear ⑤ .
- (12) Remove the bearing-Registration L 6 and besring-Registration R 7.
- (13) Remove the spring ⑧ from the bearing ⑥ , ⑦ .

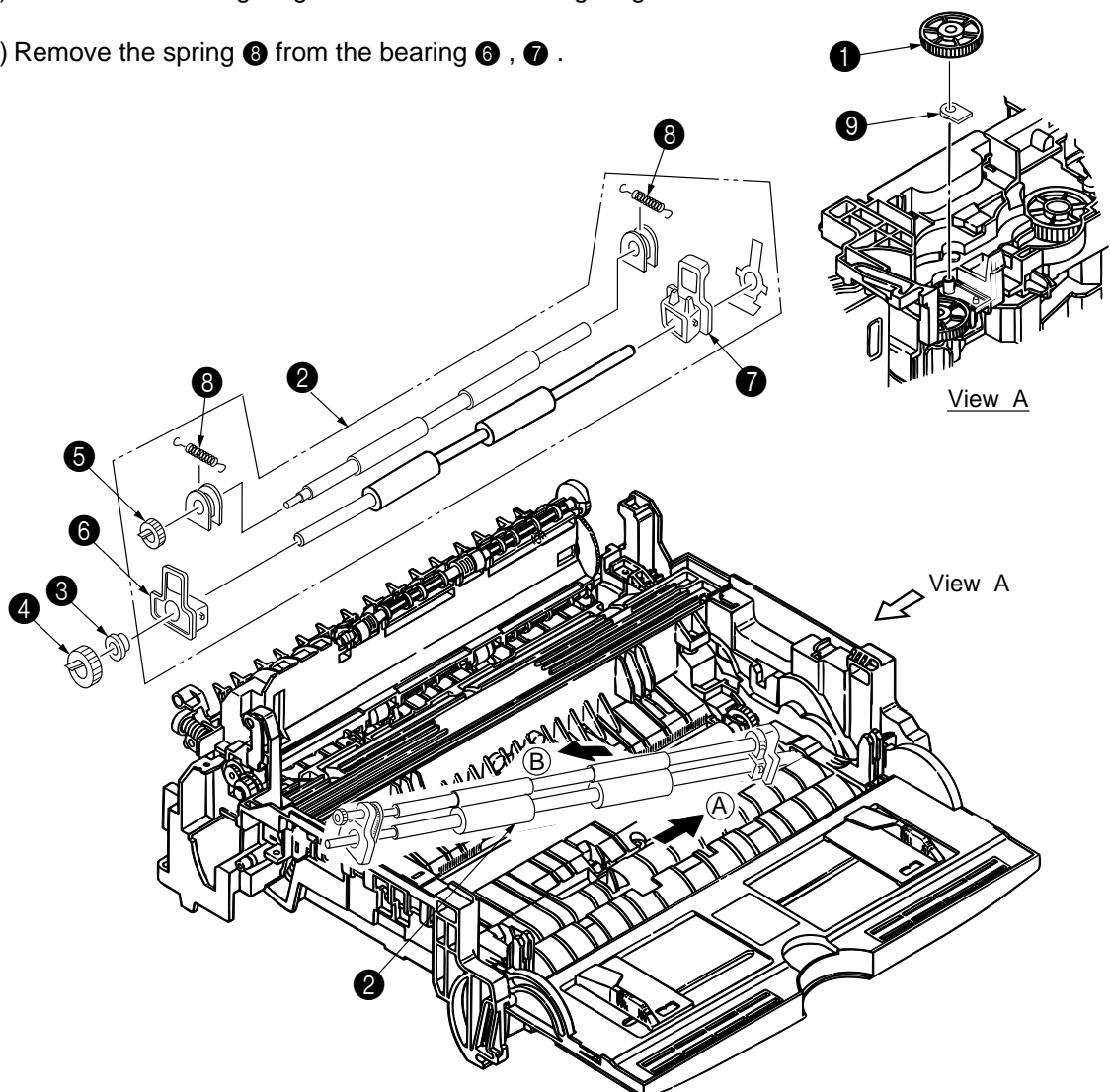

3.3.14 Roller Transfer Assy

- (1) With the power switch turned off, unplug the AC cord from the outlet.
- (2) Open the stacker cover.
- (3) Release the roller transfer assy ❶ by unlocking the latch of the main unit (never apply excessive force when unlocking the latch).
- (4) Lift the right side of the roller transfer assy ❶, and shift it to the right side, then pull it out from the main unit (at this time, the bearings ❷ of the left and right sides of the roller transfer assy ❶ will also come off).

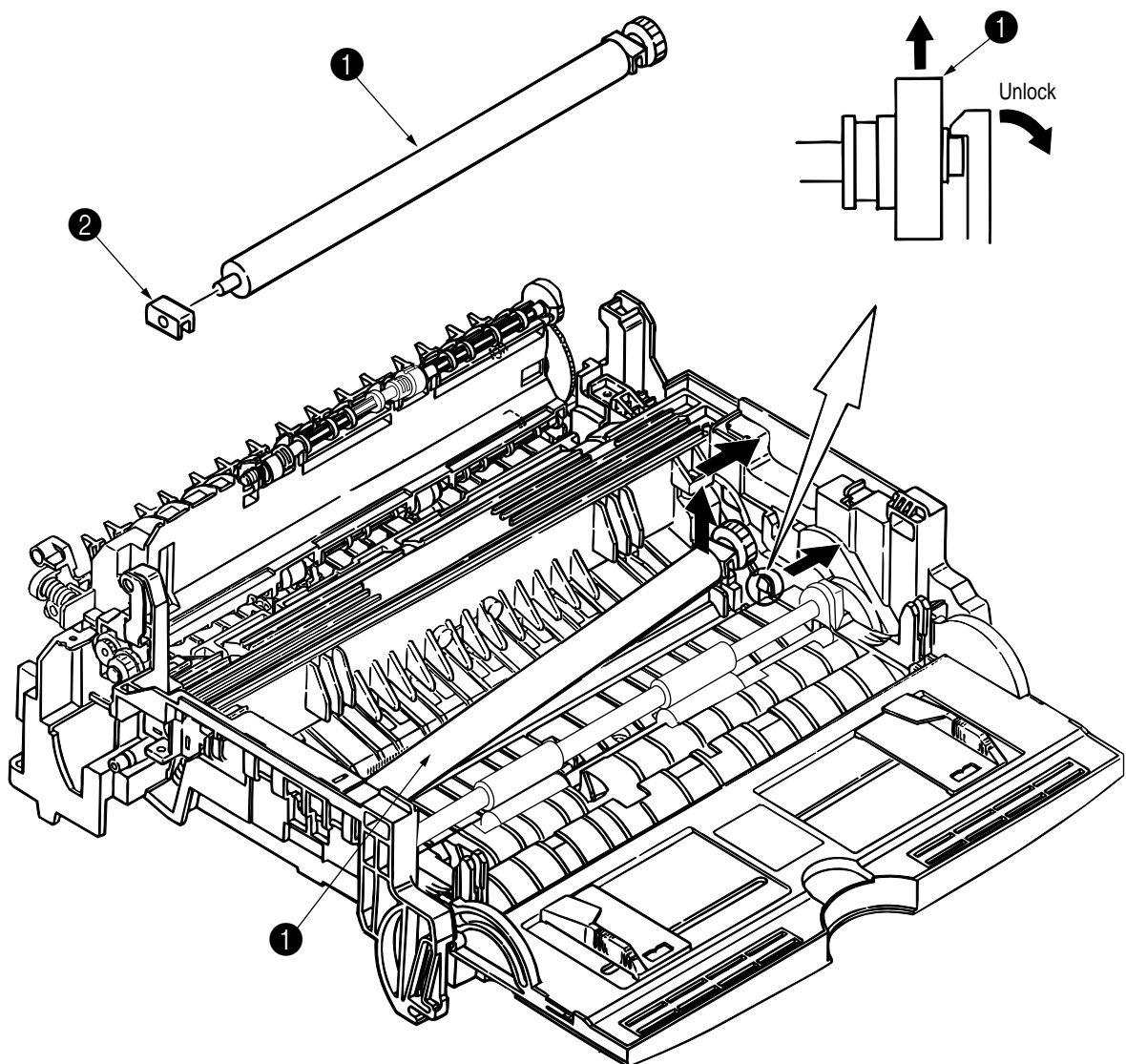

3.3.15 Fusing Unit

- (1) Remove the upper cover (see 3.3.1).
- (2) Remove the operator panel assy (see 3.3.4).
- (3) Remove the face up stacker assy (see 3.3.8).
- (4) Remove the lower base unit (see 3.3.5).
- (5) Remove the stacker cover assy (see 3.3.12).
- (6) Remove four screws ①, lift and remove the fusing unit ②.

Caution: Fusing unit may be hot. Use care when handling.

- Notes :**
1. When reinstalling or removing the fusing unit, tighten or loosen the screws while holding the fusing unit assy ② down with your hand (it is being pushed up by back up roller).
 2. When reinstalling the screws ①, be sure to direct the screws into preexisting thread and avoid damaging the threads.
 3. Do not apply excessive torque when tightening the screws ①.

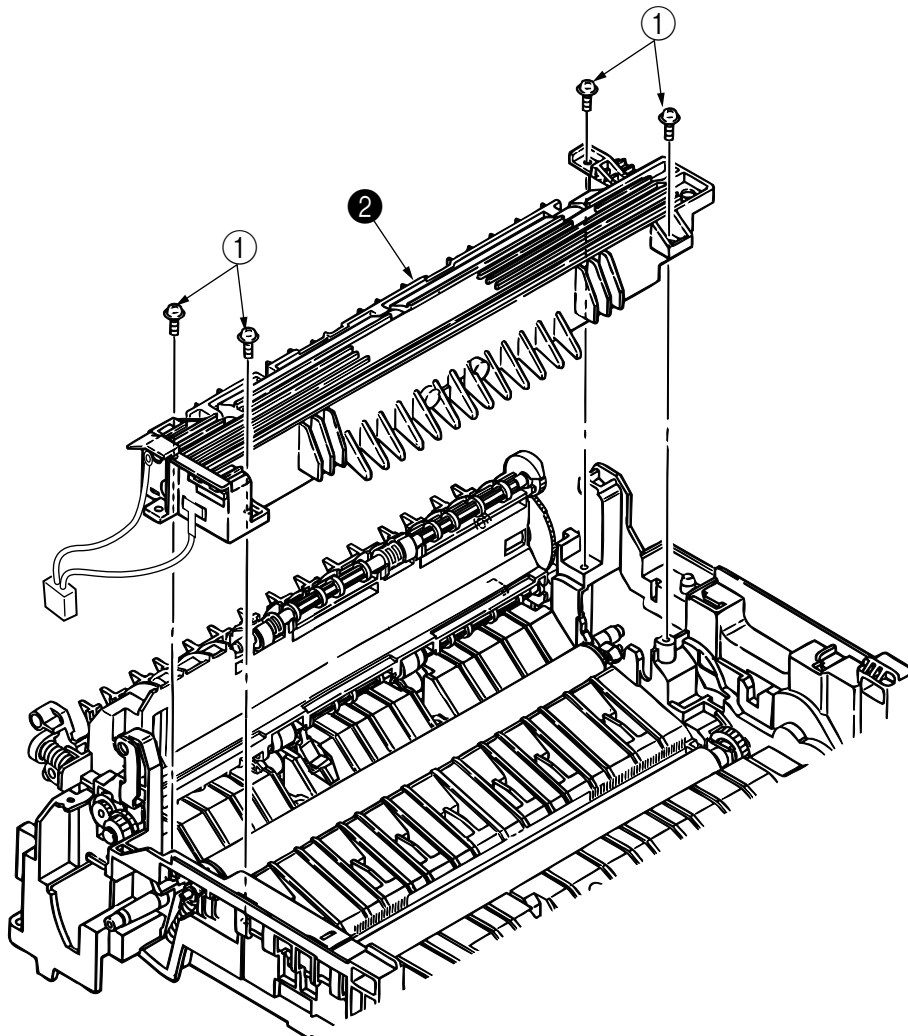

3.3.16 Back-up Roller

- (1) Remove the fusing unit assy (see 3.3.15).
- (2) Lift the left side of the back-up roller **1**, and pull it out to the left side (at this time, two bearing holders (back-up) **2** and the bias springs (back-up) **3** and the two ball-bearing **4**, washer B **5**, washer C **6** will also come off).

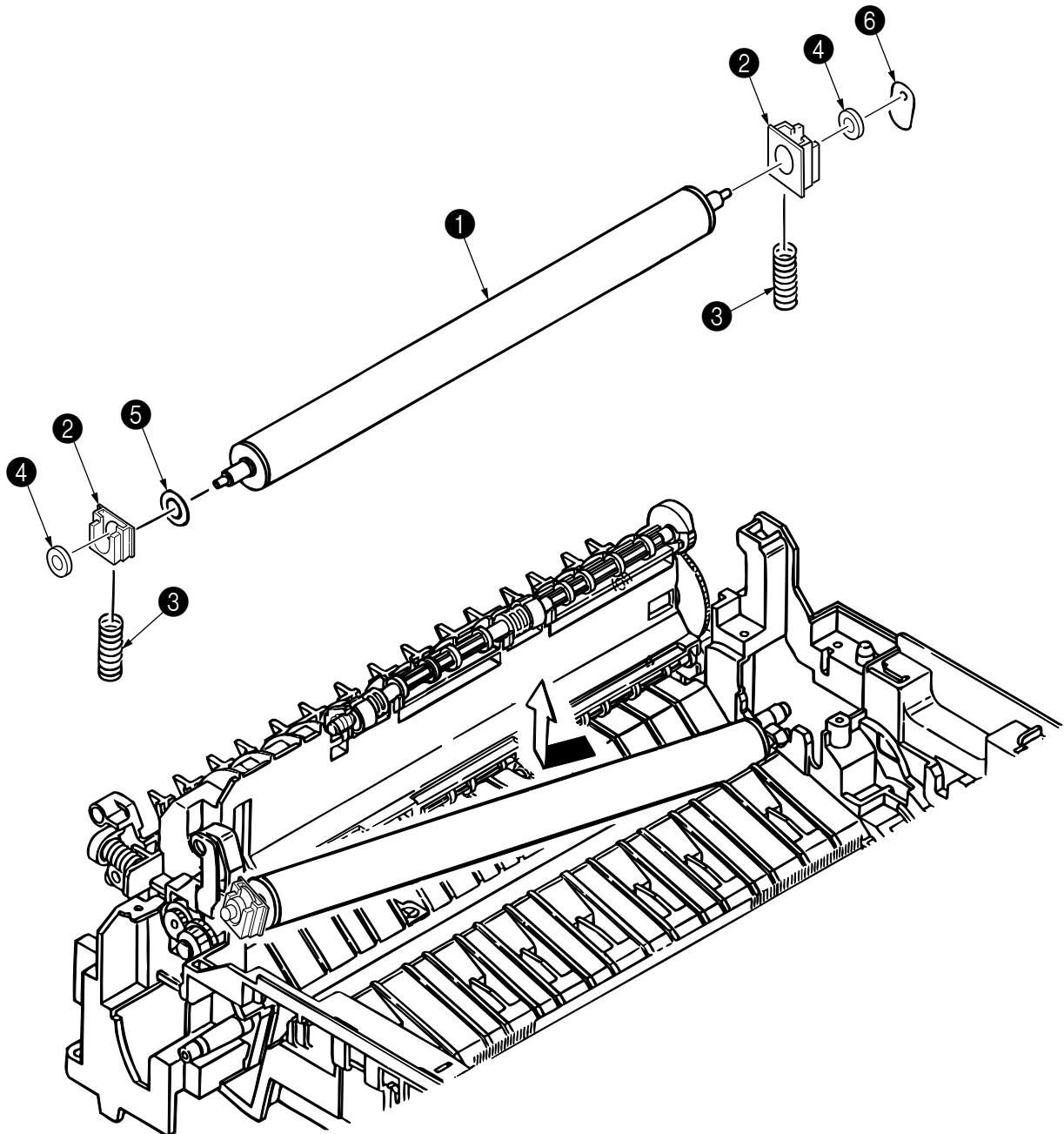

3.3.17 Sensor Plate (Inlet)

- (1) Remove the upper cover (see 3.3.1).
- (2) Remove the operator panel assy (see 3.3.4).
- (3) Remove the face up stacker assy (see 3.3.8).
- (4) Remove the lower base unit (see 3.3.5).
- (5) Press the clamps of three sensor plates (inlet and paper) ❶, and remove them by pressing them upward from the bottom.

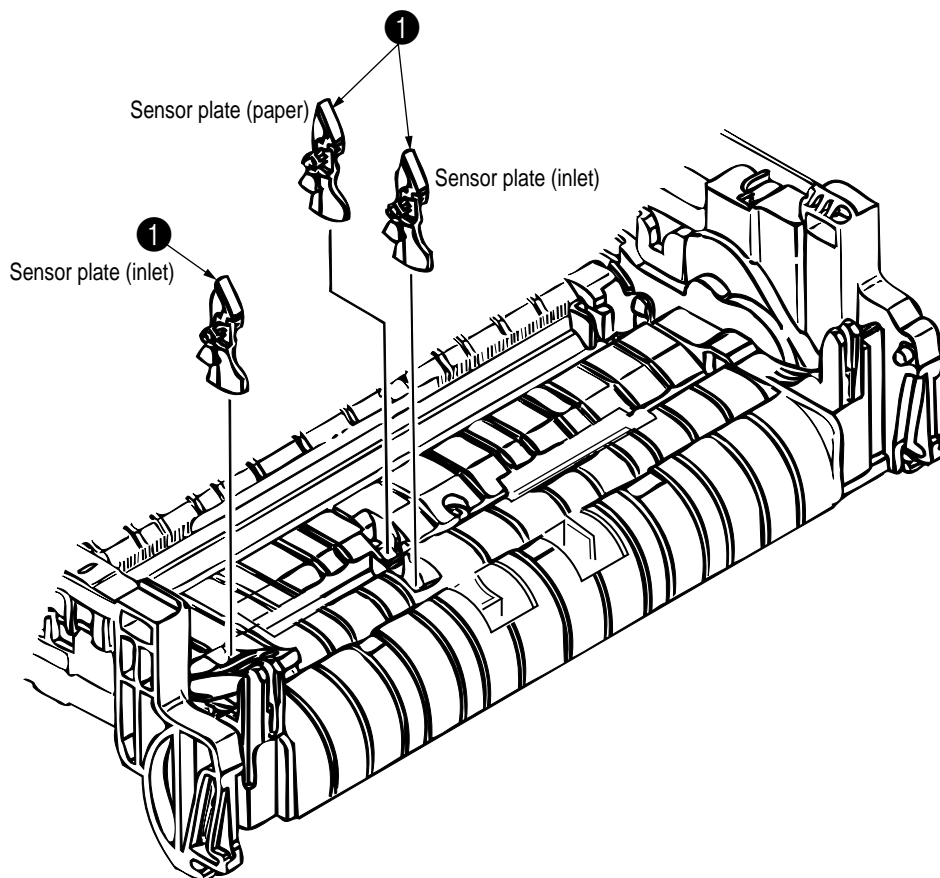
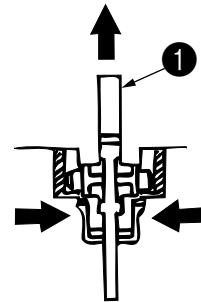

3.3.18 Sensor Plate (Outlet), Sensor Wire Assy

- (1) Remove the upper cover assy (see 3.3.1).
- (2) Remove the operator panel assy (see 3.3.4).
- (3) Remove the eject roller assy (see 3.3.9).
- (4) Remove the face up stacker assy (see 3.3.8).
- (5) Remove the lower base unit (see 3.3.5).
- (6) Remove the fusing unit assy (see 3.3.15).
- (7) Press the clamps of the sensor plate (outlet) ①, and remove the sensor plate by pushing it up.
- (8) Turn the clamps of the sensor wire assy ② remove the sensor wire assy from the lower base unit.

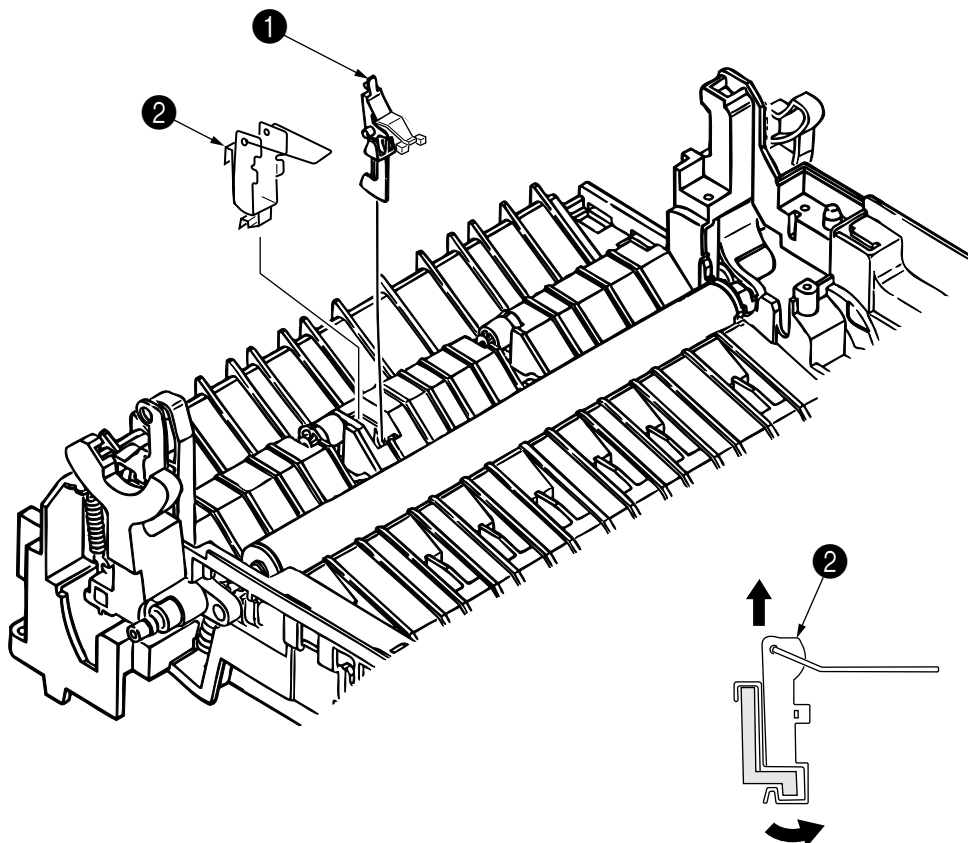
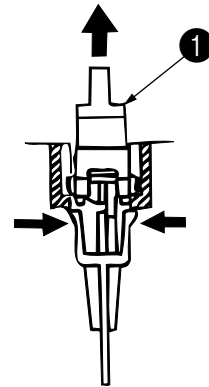

3.3.19 Manual Feed Guide Assy

- (1) Remove the upper cover assy (see 3.3.1).
- (2) Open the manual feed guide assy ❶, and release the engagement on both sides with the main unit by carefully bending the manual feed guide assy ❶.

Note : When remounting, verify the proper the engagements as shown in the diagram.

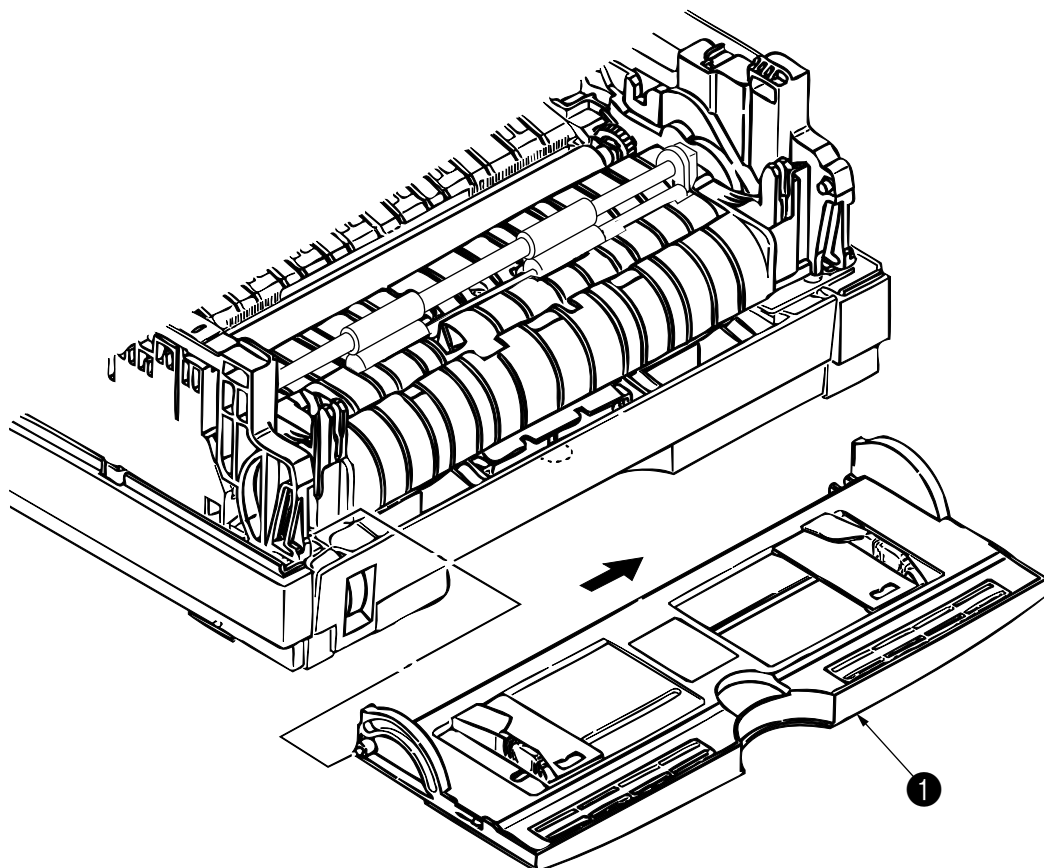
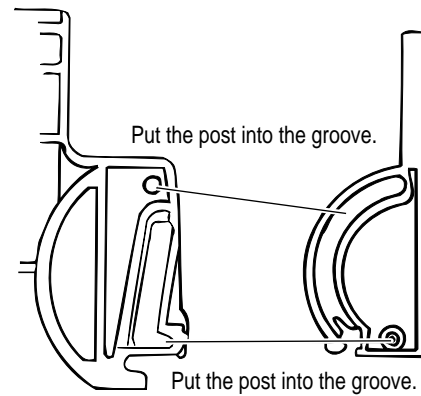

3.3.20 Sensor Plate (Paper Supply)

- (1) Remove the upper cover assy (see 3.3.1).
- (2) Remove the operator panel assy (see 3.3.4).
- (3) Remove the face up stacker assy (see 3.3.8).
- (4) Remove the lower base unit (see 3.3.5).
- (5) Press the clamps of the sensor plate (paper supply) ❶ to unlock the latch, and remove it from the base plate ❷.

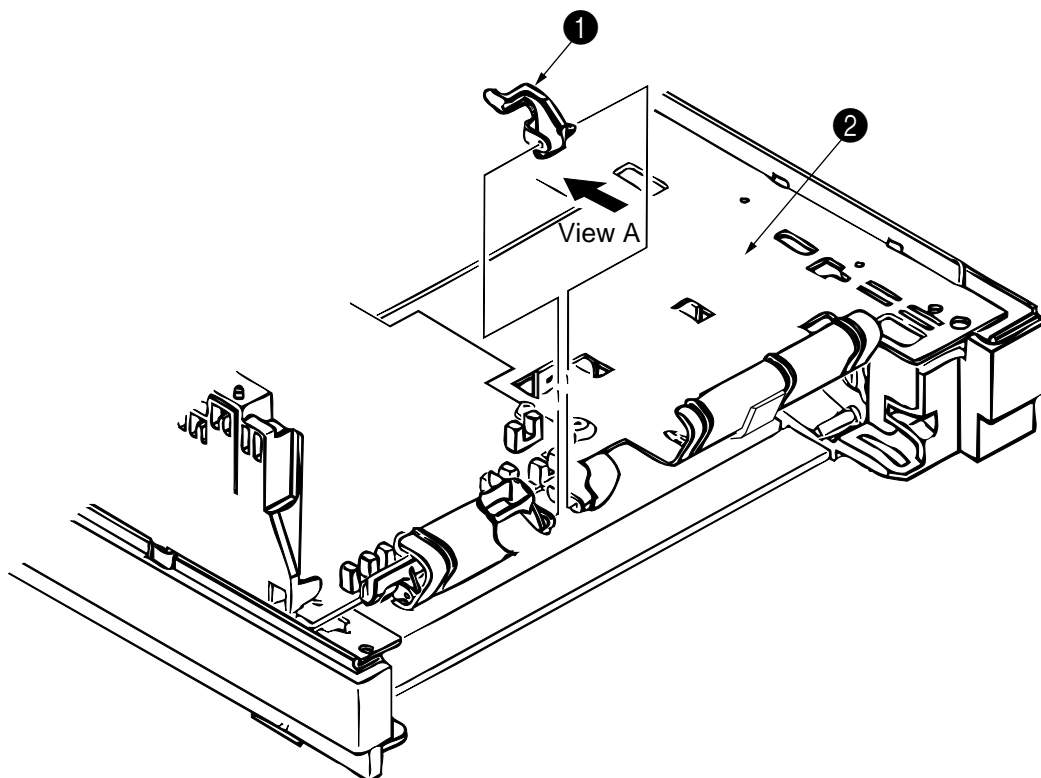
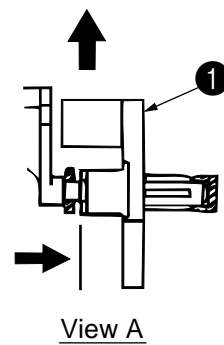

3.3.21 M7G-PCB

- (1) Remove the upper cover assy (see 3.3.1).
- (2) Remove the operator panel assy (see 3.3.4).
- (3) Remove the face up stacker assy (see 3.3.8).
- (4) Remove the lower base unit (see 3.3.5).
- (5) Remove the connector (2NDTRAY) ⑥.
- (6) Remove three screws ①.
- (7) Move the M7G-PCB ② in the direction of arrow to disconnect it from the power supply/sensor board ③.
- (8) Remove the connector FAN, and disconnect the fan motor ④.
- (9) Remove the M7G-PCB ②, together with the PCB guide plate (remove the fan motor ④ at the same time).
- (10) Remove four screws ⑧ and remove the PCB guide plate ⑦ from the M7G-PCB ②.

Note : When reinstalling the M7G-PCB ② onto the guide plate ⑦, be careful not to bend the base plate (it is desirable to place a block underneath it to prevent bending).

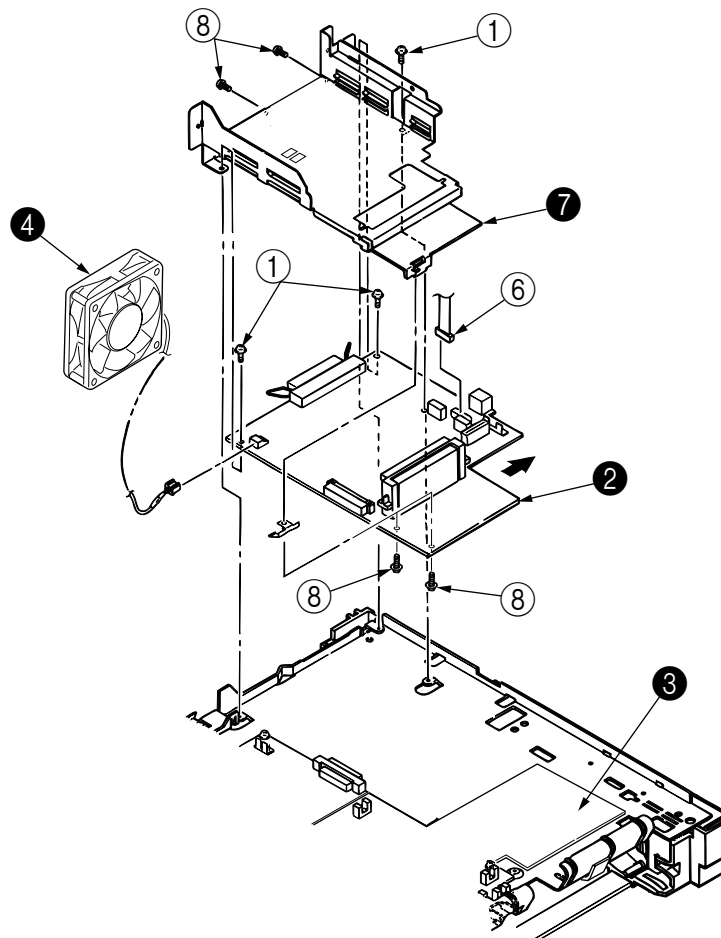

3.3.22 Power Supply/Sensor Board, High Voltage Unit and Contact Assy

- (1) Remove the upper cover assy (see 3.3.1).
- (2) Remove the lower base unit (see 3.3.5).
- (3) Remove the M7G-PCB (See 3.3.21).
- (4) Remove the AC inlet ① from the base plate ②.
- (5) Remove the screw ③ and remove the grounding (earth) wire ④.
- (6) Remove the Ferite core ⑨ from the grounding wire.
- (7) Remove nine screws ⑤, and remove the power supply/sensor board ⑥ and contact assy ⑦ together.
- (8) Unlock two latches ⑧, and remove contact assy ⑦ from the power supply/sensor board ⑥.
- (9) Remove the Insulator plate ⑨ from the base plate ②.

- Note :**
1. Be careful about the sensor (paper supply) when reinstalling the lower base.
 2. Make sure that no excessive force is applied to the power supply switch.
 3. When installing the power supply/sensor onto the base plate, be careful not to bend the base plate (it is desirable to place a block underneath it to prevent bending).

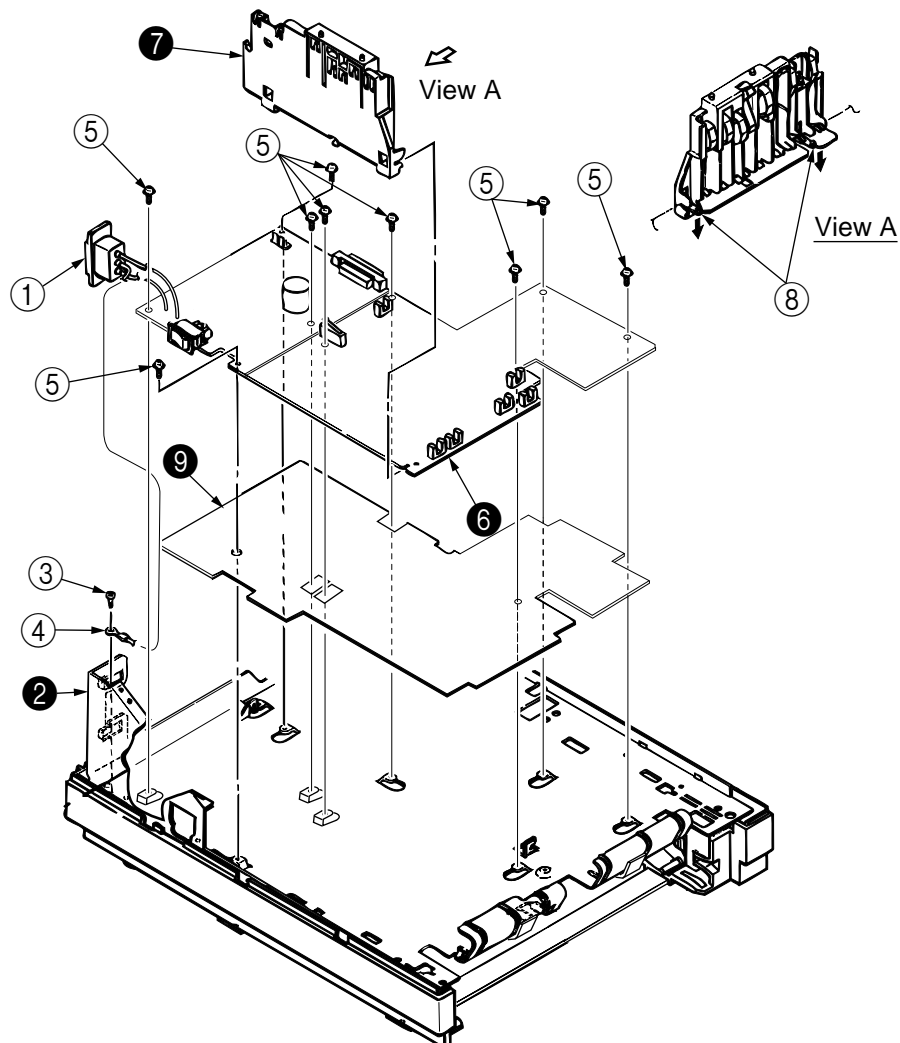

3.3.23 Cassette Guide L Assy

- (1) Remove the paper cassette.
- (2) Remove the upper cover assy (see 3.3.1).
- (3) Remove the lower base unit (see 3.3.5).
- (4) Remove the M7G-PCB (see 3.3.21).
- (5) Remove the power supply/sensor board (see 3.3.22).
- (6) Remove two screws ①, and remove the guide rails ②.
- (7) Remove the screw ③, and remove the cassette guide L assy ⑨ by shifting it in the direction of the arrow as shown below.
- (8) Remove cassette lock lever ④ and torsion spring ⑤.
- (9) Remove cassette lock lever spring ⑧ then remove the sheet link (L) ⑥ and Pull block ⑦.

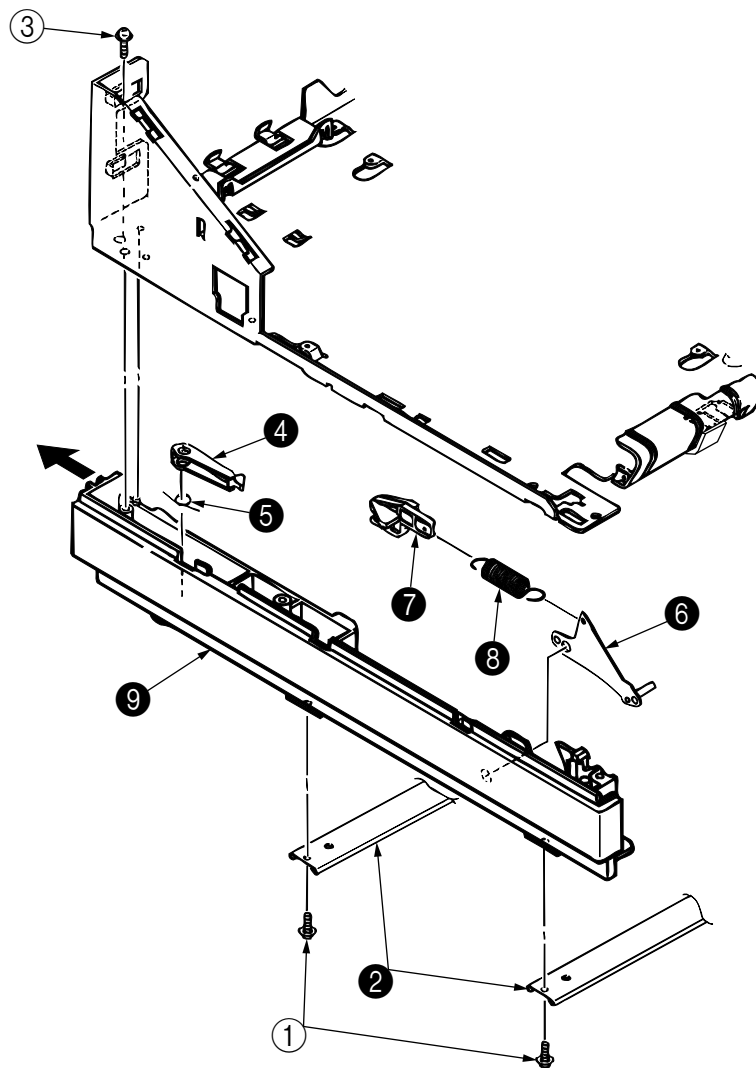

3.3.24 Cassette Guide R Assy

- (1) Remove the paper cassette.
- (2) Remove the upper cover assy (see 3.3.1).
- (3) Remove the lower base unit (see 3.3.5).
- (4) Remove the M7G-PCB (see 3.3.21).
- (5) Remove two screws ①, and remove the guide rails ②.
- (6) Remove the screw ③, and remove the cassette guide R assy ④ by shifting it in the direction of arrow.
- (7) Remove the cassette lock lever ⑤ and torsion spring ⑥.
- (8) Remove the cassette lock lever spring ⑨, then remove the sheet link (R) ⑦ and link pull block ⑧.
- (9) Remove two screws ⑩, and remove the square-shaped connector ⑪.

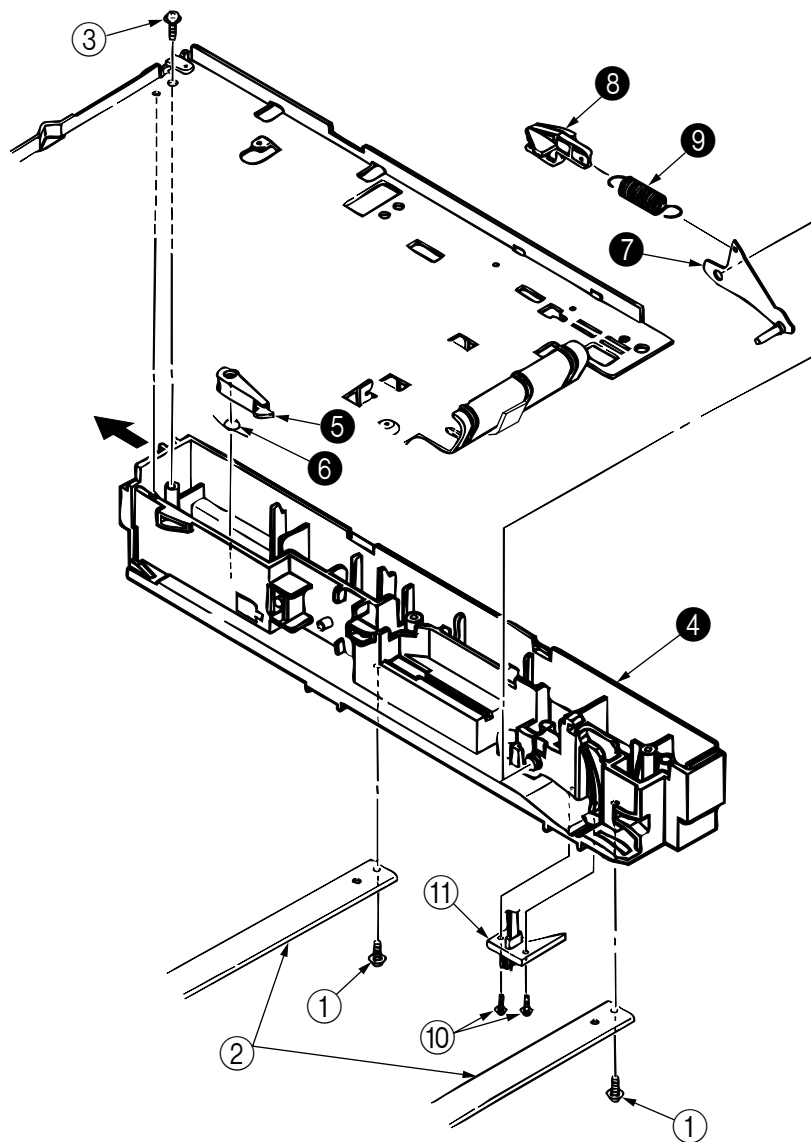

3.3.25 Spacer Bearing (L/R)

- (1) Remove the back-up roller (see 3.3.16).
- (2) Remove spacer bearing (L/R) with a tip of screw driver.

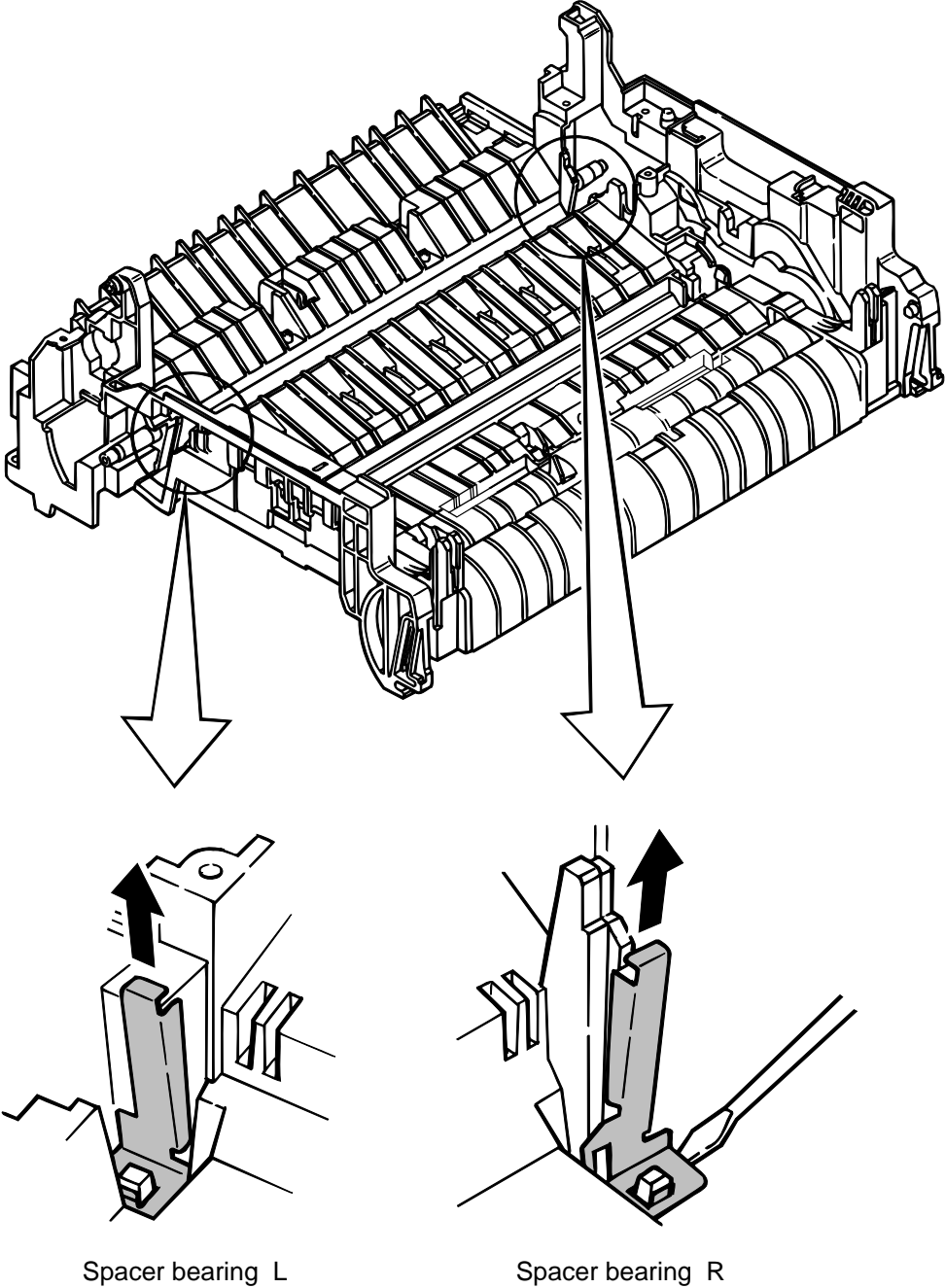

4. ADJUSTMENT

This chapter explains adjustment necessary when a part is replaced.

This adjustment is made by changing the parameter values set in EEPROM on the main control board. The status monitor or maintenance utility can be used to change these values.

Only servicemen and maintenance personnel can use the maintenance utility. This utility cannot be made public for printer end users.

4.1 Adjustment Types and Functions

4.1.1 Status Monitor (For Microsoft Windows)

This status monitor has the following functions:

- Drum counter reset
- Charge roller cleaning

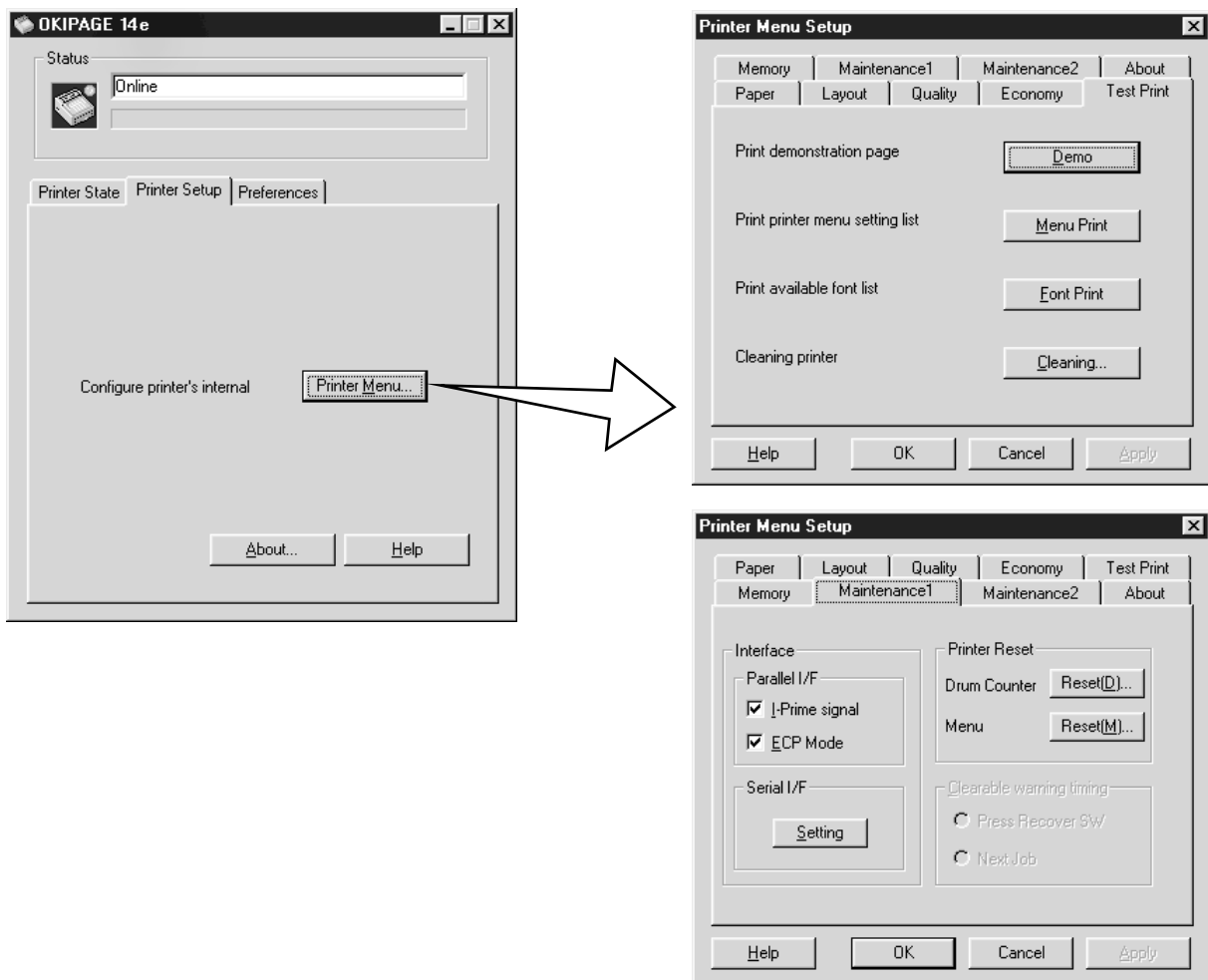

Figure 4-1

- (1) Drum counter reset
This function resets the life of the drum counter when the EP unit is replaced. Clicking the "Reset" button resets the life.
- (2) Cleaning Page Function
This function cleans the charge roller of the EP unit; it is used when printing is unclear. For details on how to operate this function, refer to "5.2.2".

4.1.2 Engine Maintenance Utility

See Appendix C.

4.2 Adjustment When Replacing a Part

The table below lists the parts that requires adjustment when they are replaced.

Part Replaced	Adjustment
LED Head	Set the LED Head drive time. Set the LED Head Width Set the LED Head Wire Set the Head type
EP unit	Reset the drum counter.(refer to "User's manual".)
Main Control Board	Upload or download EEPROM data

4.2.1 Setting of LED Head Drive Time

Caution: When the luminous intensity of a new LED head is the same as that of the old LED head, do not set the LED head drive time.

Use "LED Head Marking No." in the engine menu tab of the maintenance driver to set the luminous intensity displayed on the LED head as the LED head drive time. (See Figure 4-2.)

- Luminous intensity of LED head

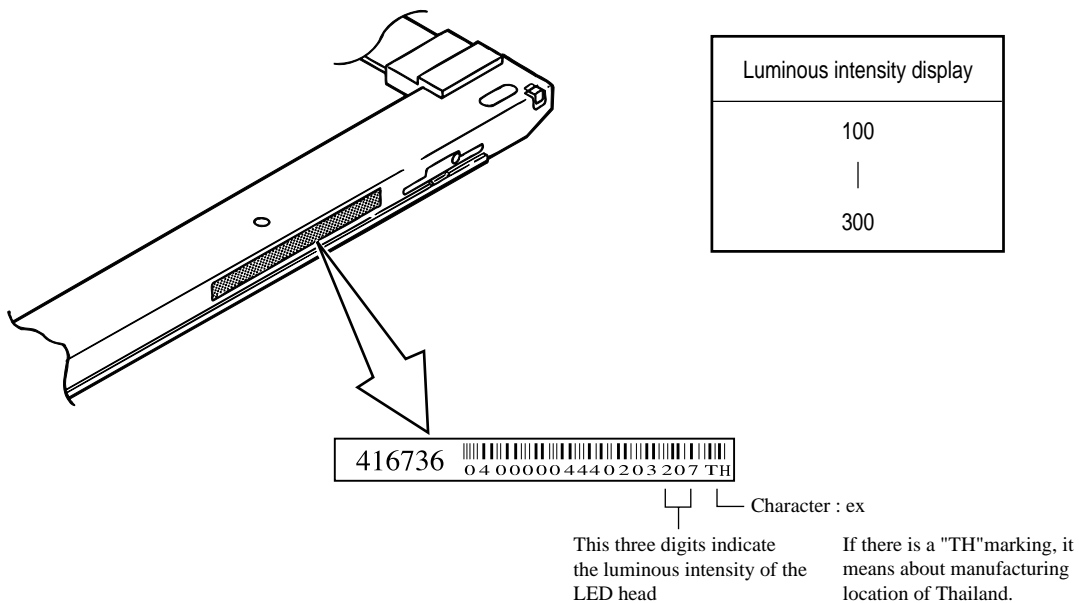

Figure 4-2

- Changing of LED Head Marking No.
 - (1) Connect the printer with the PC.
 - (2) Turn on the printer and the PC.
 - (3) Start the maintenance utility on the PC.
 - (4) Choose the LED Head, mounted on the printer, in the List Box of LED Head Marking No. (See P.133)
 - (5) Press <Entry> button to see up the LED Head for the printer.
 - (6) Press <Exit> button to end.

4.2.2 Uploading and Downloading EEPROM Data

When the main control board is replaced, EEPROM data must be reflected on a new main control board. Use "EEPROM Operations" in the option tab of the maintenance utility to reflect EEPROM data on the new main control board.

Reflect EEPROM data on the new main control board in the following procedures:

- (1) Check that the printer and PC are connected by the parallel I/F, then execute the maintenance utility.
- (2) Click the "Option" button in "Main Menu Dialog".
- (3) Click the "Upload" button (Upload EEPROM Data) in "EEPROM Operations." (EEPROM data read is completed.)
- (4) The read EEPROM data is displayed in "Dialog" of the maintenance driver.
- (5) Leave the display of the maintenance driver as is and replace the main control board.
- (6) Click the "Download" button (Download EEPROM Data) in "EEPROM Operations". (EEPROM data write is completed.)

Depending on the level of a main control board failure (parallel I/O failure, etc.), however, EEPROM data may be unable to be uploaded.

In such a case, use the maintenance utility to perform the following adjustment after replacing the main control board:

- Setting the LED head drive time (Section 4.2.1)
- Setting the LED Head Width
- Setting the LED Head Wire
- Setting the Head type
- Setting specifications (ODA/OEL/INT-A/INT-L)

5. PERIODICAL MAINTENANCE

5.1 Periodical Replacement Parts

The parts are to be replaced periodically as specified below:

Part name	Condition for replacement	Cleaning	Remarks
• Toner cartridge(Type 5)	About 2,000(ODA) or 2,500(OEL/INT) sheets of paper have been printed.	• LED head	Consumables
• Image drum cartridge (Type 8)	About 20,000 sheets of paper have been printed. See 1.4. (14)		Consumables

5.2 Cleaning

Remove any toner or dust accumulated inside the printer. Clean in and around the printer with a piece of cloth when necessary. Use the handy cleaner (service tool) to clean inside the printer.

Note: Do not touch the image drum, LED lens array, or LED head connector block.

5.2.1 Cleaning of LED Lens Array

Clean the LED lens array or replace the toner cartridge when white lines or stripes (void, light printing) are generated vertically down the page, as shown below.

Note: The LED lens array must be cleaned with an LED head cleaner included in the replacement toner kit.

White lines or stripes
(void, light printing)

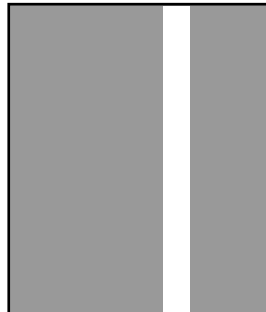

- (1) Set the LED head cleaner to the LED lens array as shown in the figure, then slide the cleaner back and forth horizontally several times to clean the head.

Note: Gently press the LED head cleaner onto the LED lens array.

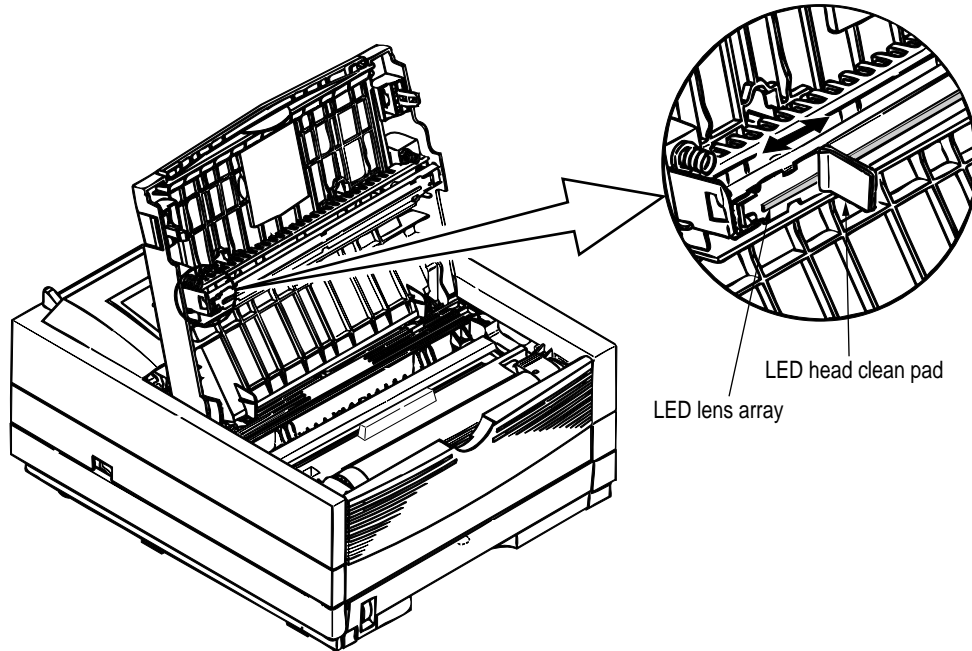

- (2) Throw the cleaner pad away.

6. TROUBLESHOOTING PROCEDURES

6.1 Troubleshooting Tips

- (1) Check the basic check points written in the user's manual.
- (2) Gather detailed failure information as much as possible from the customer.
- (3) Check the printer under the condition close to that under which the failure occurred.

6.2 Check Points Before Correcting Image Problems

- (1) Is the printer running in proper ambient conditions?
- (2) Are consumables (toner and EP unit) replaced correctly?
- (3) Are sheets of paper normal?
- (4) Is the EP unit set correctly?

6.3 Notes When Correcting Image Problems

- (1) Do not touch the surface of the OPC drum nor place foreign matter on it.
- (2) Do not expose the OPC drum to direct sunlight.
- (3) Do not touch the fuser because it heats up during operation.
- (4) Do not expose the image drum to light for more than five minutes at room temperature.

6.4 Preparation Before Troubleshooting

- (1) Message display

The failure status of printer is displayed on the status monitor of the PC.

Take proper action according to the message displayed on the status monitor.

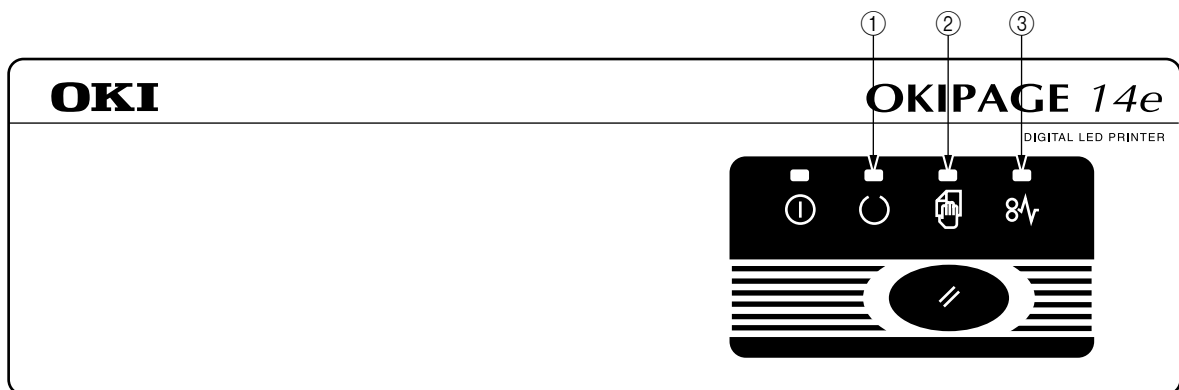

- (2) LED indicator

Printer is equipped with three LED. These LED indicates one of the following statuses:



- ① Ready LED Indicator
- ② Manual Feed LED Indicator
- ③ Error LED Indicator

LED Functions

Status	○ Ready (green)	 Manual Feed (amber)	 Error (amber)	Remark
Ready	ON	OFF	Undefined	
During suspending data processing (in OFF-LINE) (Data is left in the buffer)	Flash 1	OFF	Undefined	Printing contents of buffer by pressing switch two seconds. Clearing buffer by pressing switch five seconds.
During receiving data or processing data	Flash 2	OFF	Undefined	
Manual request	Undefined	Flash 2	OFF	
Low toner	Undefined	OFF	Flash 1	
Warning change drum	Undefined	Undefined	Flash 3	
Warning toner low, toner sensor (total page > 30 sheets)	Undefined	Undefined	Flash 1	
Error (printing Error) Buffer Overflow	OFF	OFF	Flash 2	Recovered by pressing and releasing a switch
Error Paper out, Input Jam	OFF	OFF	Flash 2	Recovered by pressing and releasing a switch and the printing can be continued.
Error Paper Jam (Paper Size Check Error, Feed Jam, Exit Jam)	OFF	OFF	Flash 2	The printing can be continued by cover open/close
Error Cover Open	OFF	OFF	Flash 2	
Program error (Watch Dog Timer Error, Controller Error)	Flash 2	Flash 2	Flash 2	Re-power on
Hardware error (fatal error) (ROM/RAM error, fuser error, thermister error and toner sensor error) (total page < 30)	Flash 3	Flash 3	Flash 3	Service call even if the printer cannot recover from one of these errors.
During printer resetting.	Flash 2	OFF	OFF	
During initializing.	ON and then OFF	ON and then OFF	ON and then OFF	
During initializing EEPROM	Flash 2, 3 times	Flash 2, 3 times	Flash 2, 3 times	
Drum counter being reset	Flash 2, 2 times	Flash 2, 2 times	Flash 2, 2 times	

Flash 1: Slow blinking

Flash 2: Blinking

Flash 3: Fast blinking

6.5 Troubleshooting

If a trouble occurs in the printer, troubleshoot according to the following procedures:

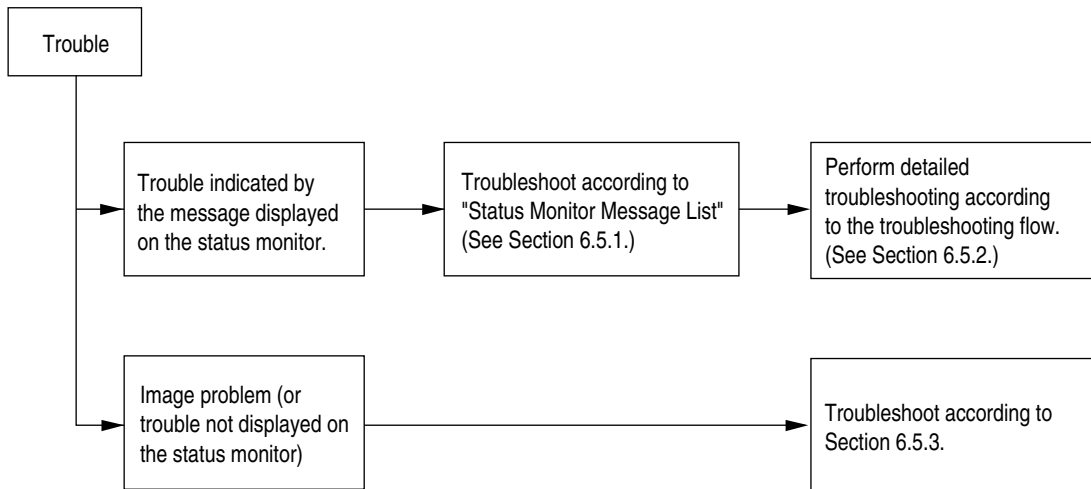

6.5.1 Status Monitor Message List

Table 6-1 lists the statuses and troubles to be displayed on the status monitor in the message format.

Table 6-1

Category	Status Message	Code	Display Content	Remedy
Normal status	Warming Up	10003	Warming-up status	Normal operation
	Online (Ready)	10001	Online (ready) status	Normal operation
	Power Save Mode	10094	Power save status	Normal operation
	Toner Low	10006	The toner amount of the toner cartridge is small.	Normal operation
	Toner Sensor	10093	The I/D unit is not installed or the toner sensor is faulty.	Install the I/D Unit or replace the toner sensor.
	Change Drum	40093	Life of I/D drum	Change the I/D Unit and reset Drum counter see Section 4.1.1 (1)
	Manual Paper In	10097	The paper is in the manual feed mode.	Replace the I/D unit. (Note: Be sure to reset the drum counter after replacing the I/D unit.)
	Printing In Progress	10098	Printing in progress X=0, Non Warning X=1, Toner Low X=2, 3 Change Drum	Normal operation
	Ejection In Progress	10099	Ejection in progress X=0, Non Warning X=1, Toner Low X=2, 3 Change Drum	Normal operation
	Manual Request Executive Letter Legal 14 Legal 13 A6 A5 A4 B5 Monarch COM-10 DL C5 COM-9	411xx	Request the paper to be set in the manual feed mode. The paper sizes are as follows: Executive, Letter, Legal 13, A4, A5, A6, B5, Monarch, DL, C5, COM-10, COM-9 xx: Paper size in the tray being selected	Set the requested paper in the manual feed mode.

Table 6-1 (Cont'd)

Category	Status Message	Code	Display Content	Remedy
Paper size error	Paper Size Error	30034	Paper of improper size was fed. 2.52" (64 mm) L 15.77" (400.56 mm)	Check the paper. Also check whether more than one sheet of paper were fed simultaneously. To release the error display, open the cover, then close it. If this error occurs frequently, see Section 6.5.2.3.
Paper jam	Paper Input Jam	40077	A paper jam occurred when sheets of paper were being supplied.	Check the paper. To release the error display, close the cover, then close it. If this error occurs frequently, see Section 6.5.2.2-1.
	Paper Feed Jam	40078	A paper jam occurred during paper feeding.	Open the cover, then remove the jammed paper. To release the error display, close the cover. If this error occurs frequently, see Section 6.5.2.2-2.
	Paper Exit Jam	40079	A paper jam occurred during paper ejection.	Open the cover, then remove the jammed paper. To release the error display, close the cover. If this error occurs frequently, see Section 6.5.2.2-3.
Cover open	ID Not Installed	40019		Installed I/D Unit
	Cover Open	40021	The upper cover is open.	To release the error display, close the cover. If this error occurs frequently, replace the power supply board.
Buffer overflow	Page Buffer Overflow	30097	The page buffer overflowed because there are a large number of print data.	To release the error display, press the reset button on the status motor of the printer driver. Install RAM or reduce the number of print data.
Device configuration error	Program ROM Check Error		An error occurred during program ROM check.	Replace program ROM or the main control board. (When replacing the main control board, also adjust EEPROM data.) (See Section 4.2.4.)
	Resident RAM Check Error		An error occurred during resident RAM check.	Replace the main control board. (When replacing the main control board, also adjust EEPROM data.) (See Section 4.2.4.)
	EEPROM Check Error		An error occurred during EEPROM check.	Replace the main control board. (When replacing the main control board, also adjust EEPROM data.) (See Section 4.2.4.)

Table 6-1 (Cont'd)

Category	Status Message	Code	Display Content	Remedy
Device configuration error	Option RAM Check Error		An error occurred during option RAM check.	Check the connection of the Option RAM PC board. If the option RAM PC board is faulty, replace it.
	Fuser Error	40084	A heater timeout error occurred.	See Section 6.5.2 4.
	Thermister Open Check Error		The thermistor is open.	Replace the heater Assy.
	Thermister Short Check Error		A thermistor short occurred.	Replace the heater Assy.
	Watch Dog Timeout Error		A watchdog timeout occurred.	To release the error display, turn on the power supply again. Replace the main control board.
	Motor Timeout Error		A motor timeout occurred.	To release the error display, turn on the power supply again. Replace the main control board.

6.5.2 Status Message Troubleshooting

If the problems cannot be corrected by using the status message/problem list, follow the troubleshooting flowcharts given here to deal with them.

No.	Trouble	Flowchart number
1.	The printer does not work normally after the power is turned on.	①
2.	Jam alarm <ul style="list-style-type: none">— Paper input jam— Paper feed jam— Paper exit jam	②-1 ②-2 ②-3
3.	Paper size error	③
4.	Fusing unit error	④
5.	SSIO (Synchronous Serial Input/Output) error I/F timeout (no response) between the printer and an optional tray (High Capacity Second Paper Feeder, Power Envelope Feeder).	⑤
6.	Fan error	⑥

① The printer does not work normally after the power is turned on.

- Turn the power off, then back on.

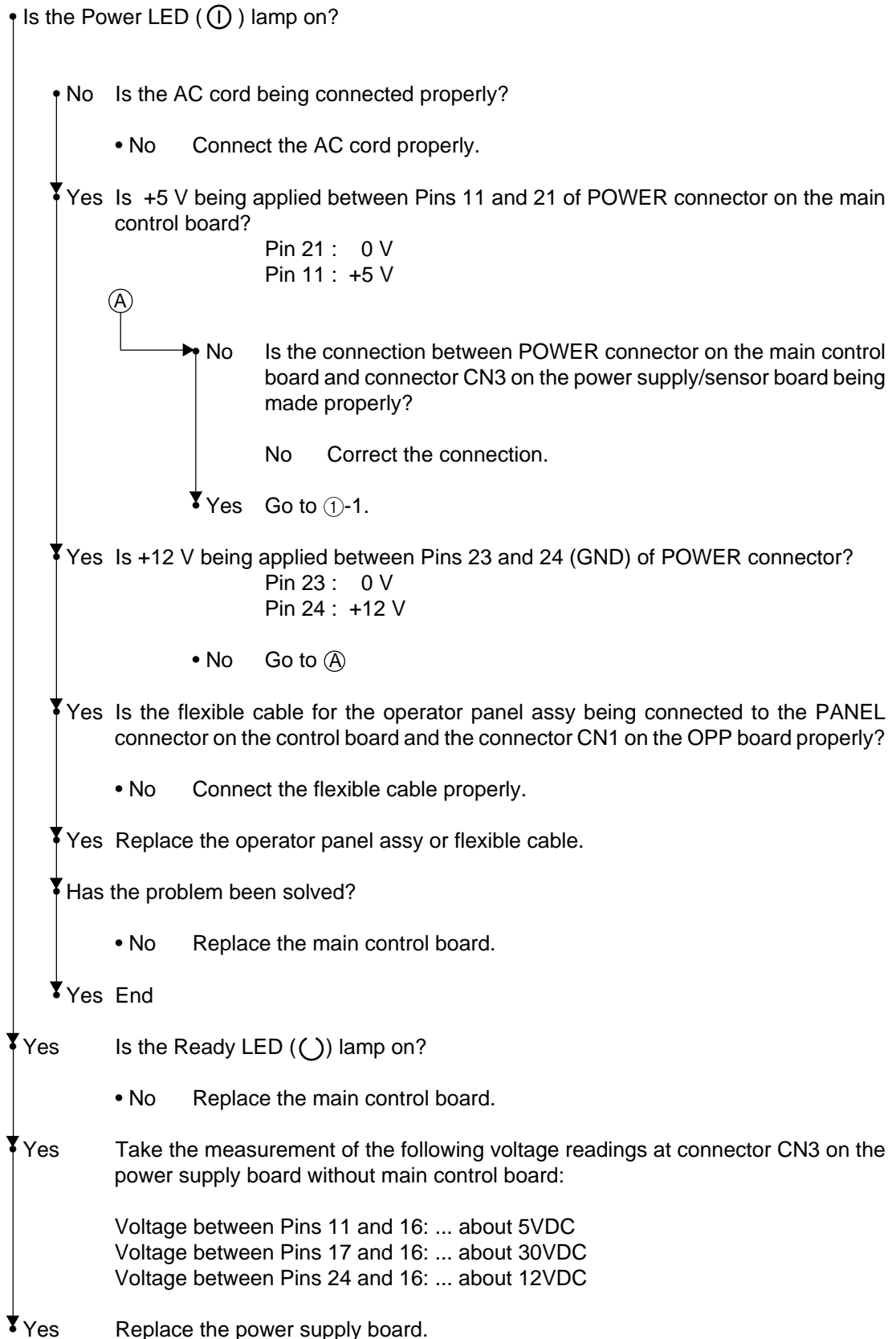

②-1 Paper input jam

- Does the JAM error occur when the power is turned on?
 - Yes Is the paper at the inlet sensor?
 - Yes Remove the paper.
 - No Is the operation of the inlet sensor plate normal (moves freely when it is touched)?
 - No Replace the inlet sensor plate.
 - Yes Clean the inlet sensor on the power supply/sensor board, or replace the power supply/sensor board.
- No Does the JAM alarm occur after paper feeding?
 - Yes Is the paper fed to the inlet sensor plate?
 - Yes Is the operation of the input sensor plate normal (moves freely when it is touched)?
 - No Replace the inlet sensor plate.
 - Yes Clean the inlet sensor on the power supply/sensor board or replace the power supply/sensor board.
 - No Replace the hopping roller rubber or paper cassette.
- No Is the hopping roller rotating?
 - Yes Set the paper tray properly.
- No Is the registration motor rotating?
 - Yes Replace the one-way clutch gear of the hopping roller assembly.
- No Is RM connector on the main control board being connected properly?
 - No Connect RM connector properly.
- Yes Is the coil resistance (normal resistance: both between Pins 1 and 2, as well as Pins 3 and 4 are about 9.5Ω) of the registration motor normal?
 - No Replace the registration motor.
- Yes Replace the main control board.

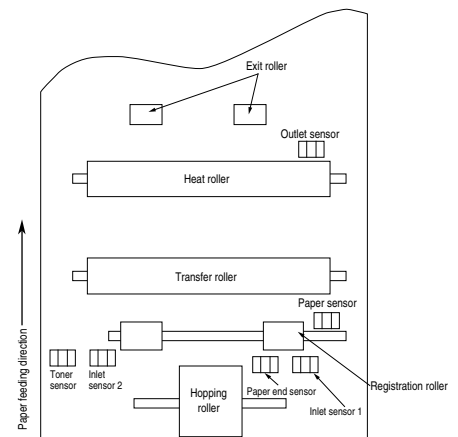

②-2 Paper feed jam

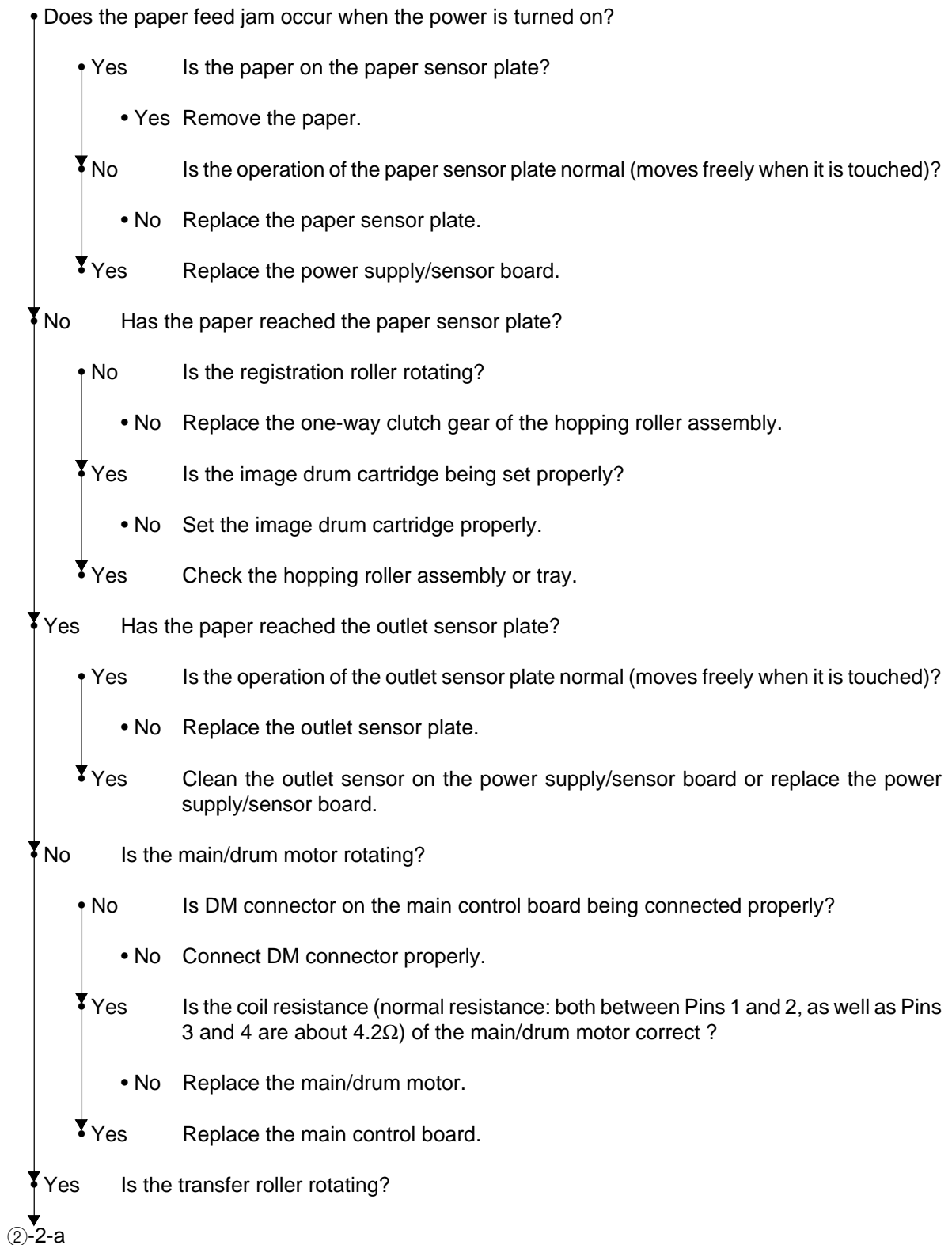

②-2-a

- No Check the gears (transfer roller gear, idle gear and reduction gear).
- ▼ Yes Is the fusing unit being installed properly?
 - No Install the fusing unit properly.
- ▼ Yes Is the image drum cartridge being set properly?
 - No Set the image drum cartridge properly.
- ▼ Yes Clean the paper sensor on the power supply/sensor board or replace the power supply/sensor board.

[JAM error]

②-3 Paper exit jam

- Does the paper exit jam error occur when the power is turned on?
 - Yes Is the paper on the outlet sensor plate?
 - Yes Remove the paper.
 - ▼ No In the operation of the outlet sensor plate normal (moves freely when it is touched)?
 - No Replace the outlet sensor plate.
 - ▼ Yes Clean the outlet sensor on the power supply/sensor board or replace the power supply/sensor board.
- ▼ No Is the face-up stacker pulled out completely from the printer or, pushed into the printer completely?
 - No Pull the face-up stacker out of the printer completely or push it into the printer completely.
- ▼ Yes Is the eject roller assembly being installed properly?
 - No Install the eject roller assembly properly.
- ▼ Yes Has the coil spring come off the eject roller assembly?
 - Yes Install the coil spring to the eject roller assembly.
- ▼ No Replace the eject roller assembly.

③ Paper size error

- Is paper of the specified size being used?
 - No Use paper of the specified size.
- Yes Are inlet sensor plates 1 and 2 operating properly (moves freely when they are touched)?
 - No Replace the inlet sensor plate or clean the inlet sensor on the power supply/sensor board.
- Yes Does the outlet sensor plate operate properly (moves freely when it is touched)?
 - No Replace the outlet sensor plate or clean the outlet sensor on the power supply/sensor board.
- Yes Replace the power supply/sensor board.

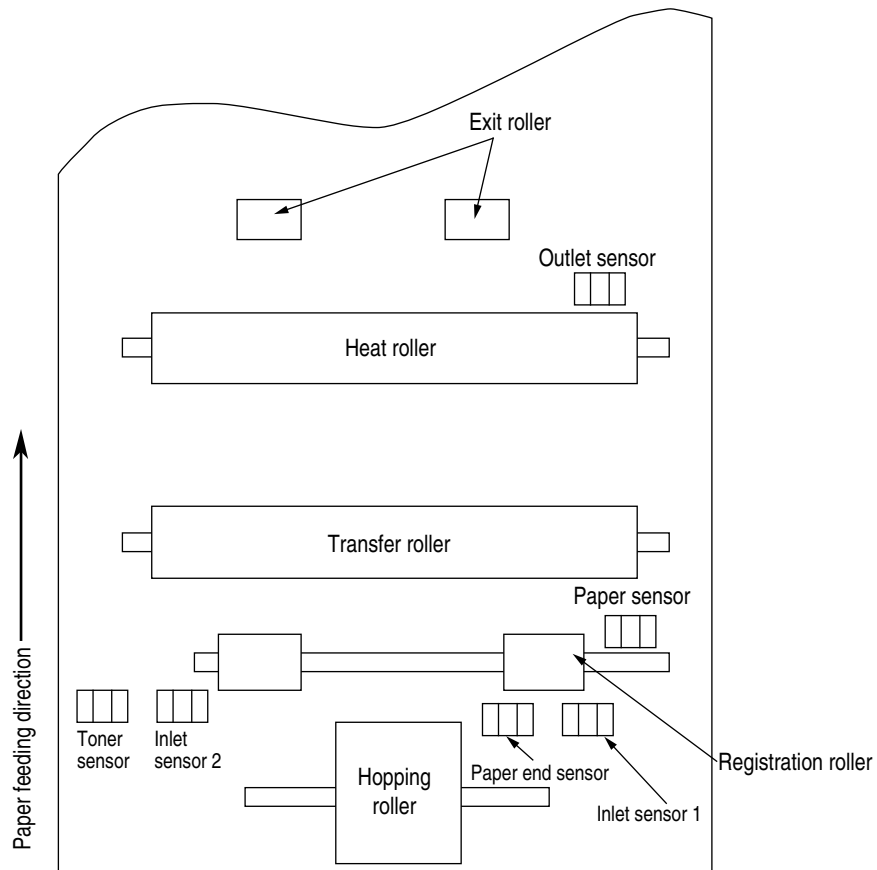

④ Fusing unit error (Status Message : Thermister Open Error
: Thermister Short Check Error
: Fuser Error)

- Turn the power off, then back on again.
- ▼ Yes Is the thermistor open or shorted? Measure the resistance between thermistor contacts (heater contacts 120V/3Ω or 240V/10Ω, and thermistor contacts 220KΩ at room temperature) (see Figure 6-2 or Section 7.3).
 - Yes Replace the fusing unit.
- ▼ No Do the thermistor contacts touch the contact assembly properly when the fusing unit is mounted in the printer?
 - No Adjust the contacts of the contact assembly.
- ▼ Yes Is the heater of the fusing unit turned on (when the heater is turned on, light is emitted)?
 - Yes Check the thermistor contacts or replace the main control board or the fusing unit.
- ▼ No Is the AC voltage being supplied to the connector for the heater of the power supply board? (see Figure 6-2)
 - No Replace the main control board or the power supply/sensor board.
- ▼ Yes Check the heater connector cord and the heater contact for poor contact (see Figure 6-4 contact ㉔).

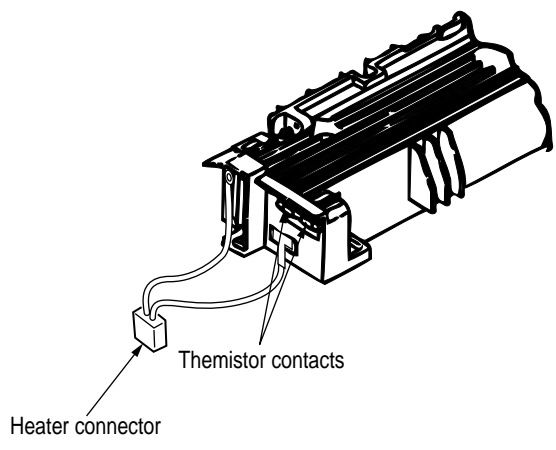
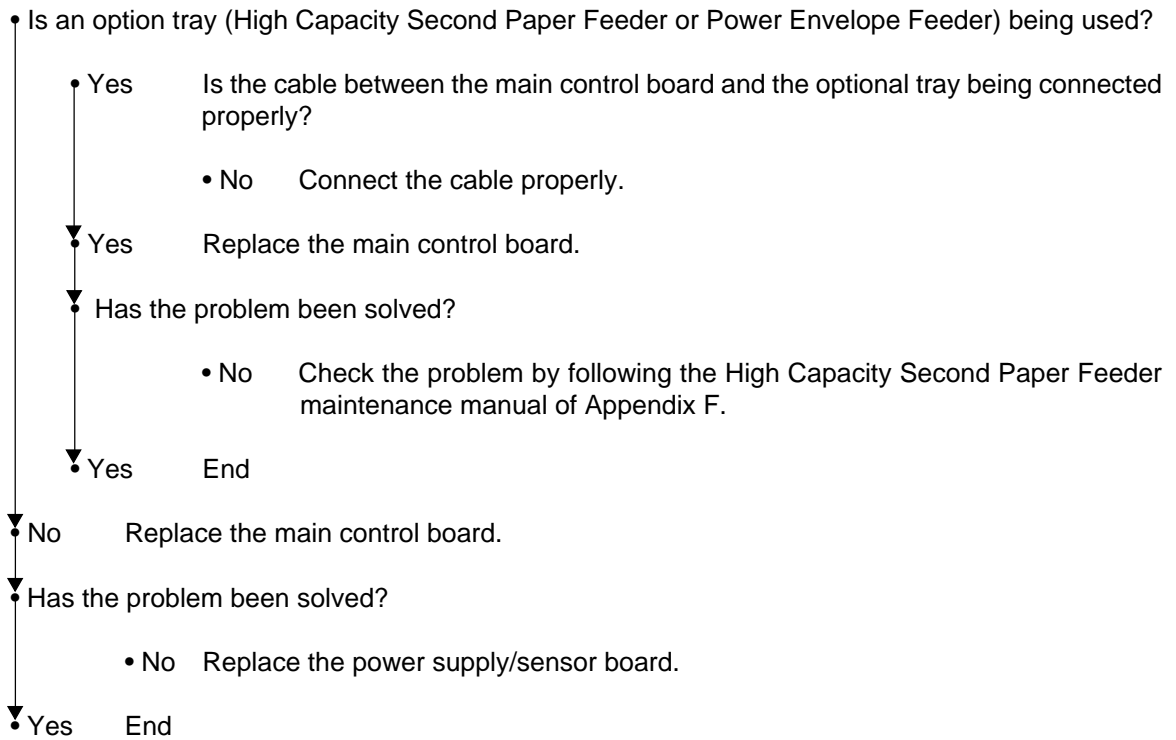
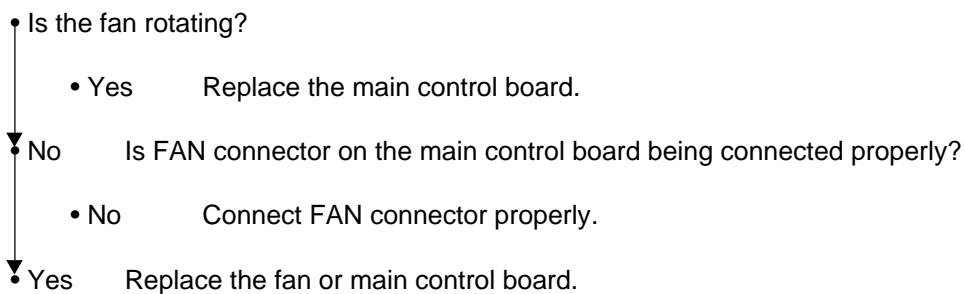

Figure 6-2

⑤ Synchronous serial I/O error (Status Message : SSIO Error) or I/F timeout between printer and optional tray (Status Message : Tray2 Timeout Error or Feeder Timeout Error)



⑥ Fan error (Status Message : FAN Motor Error)



6.5.3 Image Troubleshooting

Procedures for troubleshooting for abnormal image printouts are explained below. Figure 6-3 below shows typical abnormal images.

Problem	Flowchart number
Images are light or blurred entirely (Figure 6-3 (A))	①
Dark background density (Figure 6-3 (B))	②
Blank paper is output (Figure 6-3 (C))	③
Black vertical belts or stripes (Figure 6-3 (D))	④
Cyclical defect (Figure 6-3 (E))	⑤
Prints voids	⑥
Poor fusing (images are blurred or peels off when the printed characters and images on the paper are touched by hand)	⑦
White vertical belts or streaks (Figure 6-3 (F))	⑧

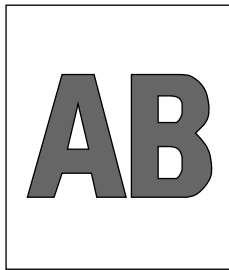

Ⓐ Light or blurred images entirely

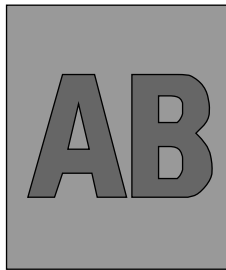

Ⓑ Dark background density

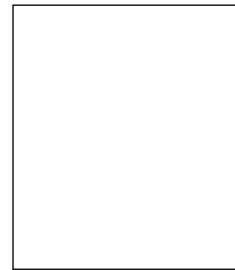

Ⓒ Blank paper

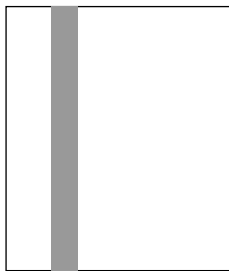

Ⓓ Black vertical belts or stripes

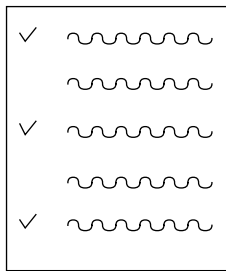

Ⓔ Cyclical defect

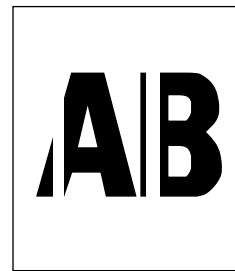

Ⓕ White vertical belts or streaks

Figure 6-3

① Images are light or blurred entirely.

- Is toner low (is the TONER LOW message displayed)?
 - Yes Supply toner.
- ▼ No Is paper of the specified grade being used?
 - No Use paper of the specified grade.
- ▼ Yes Is the lens surface of the LED head dirty?
 - Yes Clean the lens.
- ▼ No Is the LED head being installed properly (check the HEAD1 connector of the main control board and PC connector on the LED head for proper connection)?
 - No Install the LED head properly.
- ▼ Yes Is the contact plate of the transfer roller in contact with the contact assembly of the power supply/sensor board properly (see Figure 6-5)?
 - No Adjust the contact plate of the transfer roller to make a proper contact with the power supply/sensor board and shaft of the transfer roller.
- ▼ Yes Are the contact of the developing roller and the contact of the toner supply roller of the image drum cartridge in contact with the contact assembly properly (see Figure 6-4 (A) and (B))?
 - No Adjust the contacts of the developing and toner supply roller to make a proper contact with the contact assembly.
- ▼ Yes Replace the transfer roller.
- ▼ Has the problem been solved?
 - Yes End
- ▼ No Replace the image drum cartridge.
- ▼ Has the problem been solved?
 - Yes End

Note: After replacing the image drum cartridge, reset the drum counter by clicking the "Reset" button in the Status Monitor. (See Printer Handbook).
- ▼ No Is the tension between the back-up roller (7.52kg) and the surface of back-up roller normal?
 - No Replace the back-up roller or bias spring.
- ▼ Yes Replace the main control board or power supply/sensor board.

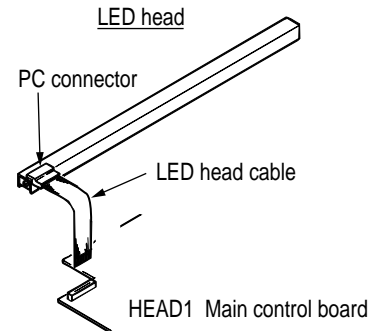

② Dark background density

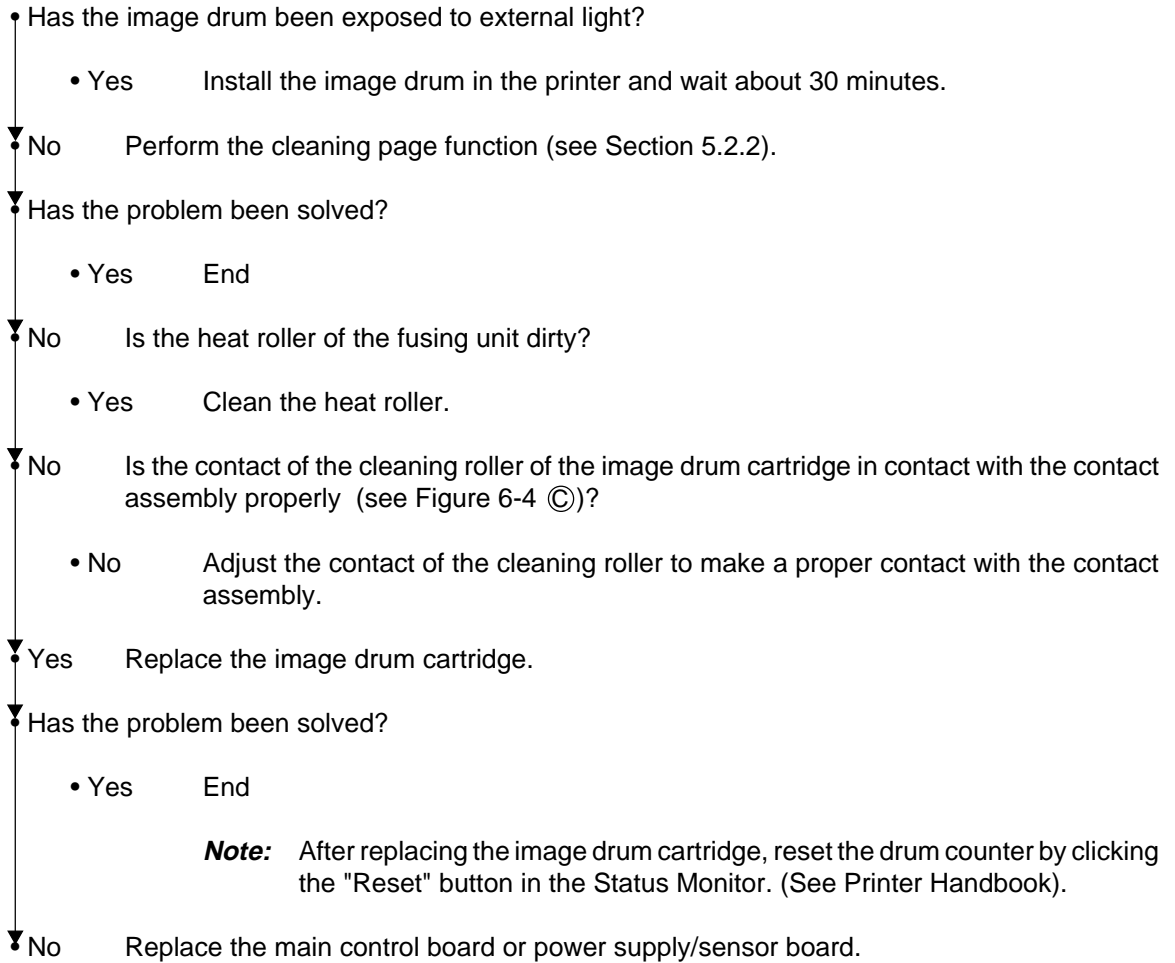

③ Blank paper is output.

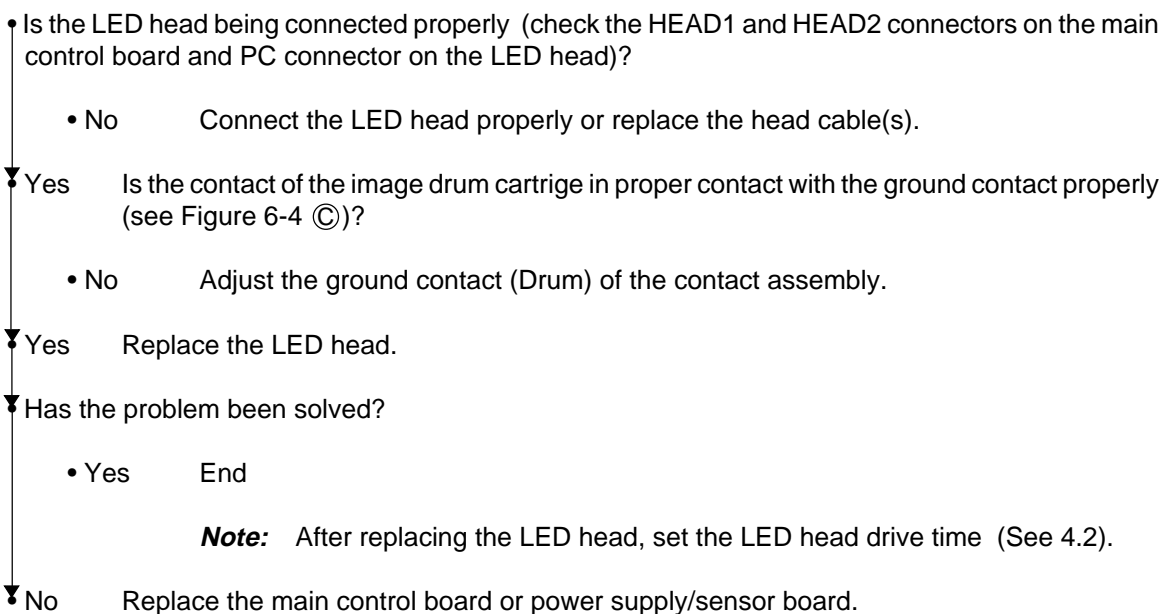

④ Black vertical belts or stripes

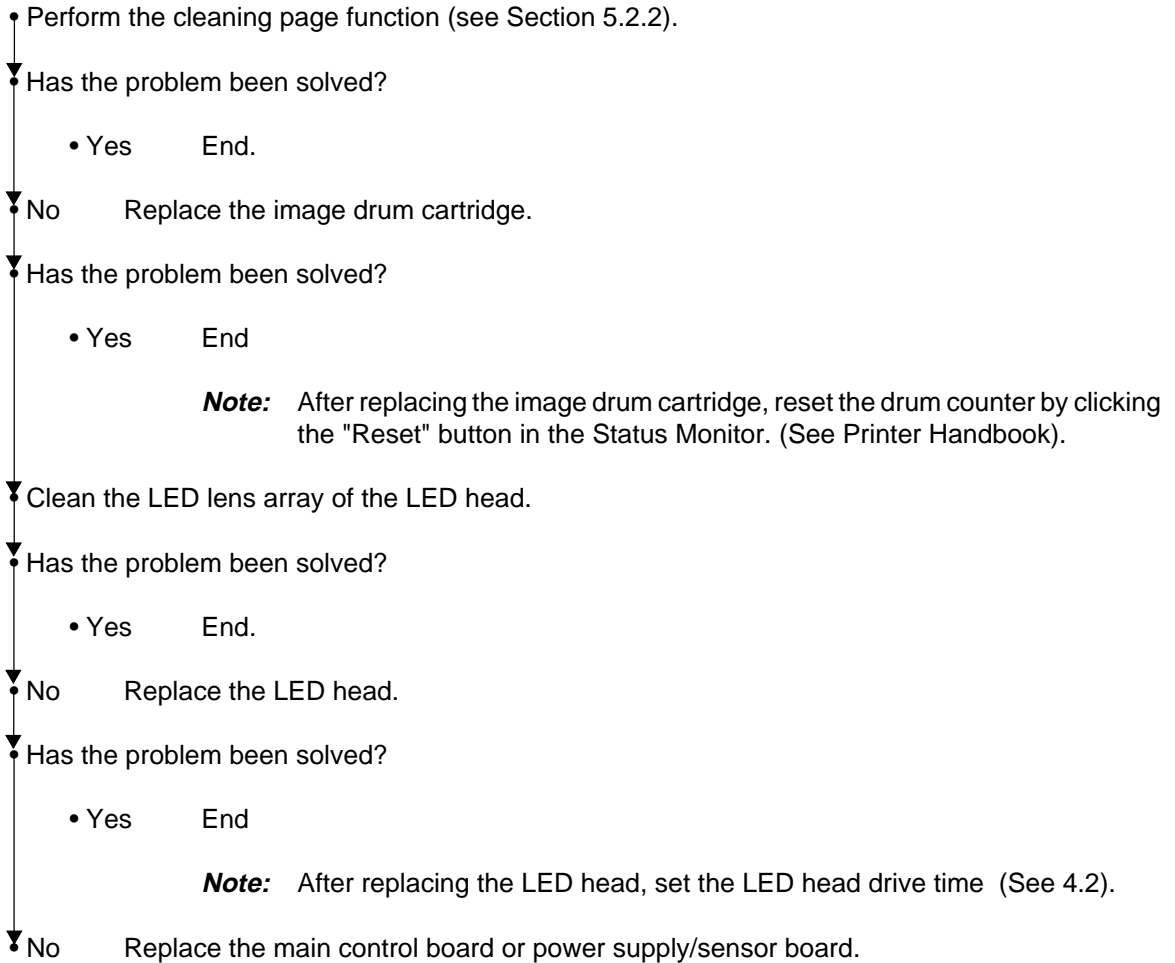

⑤ Cyclical defect

	Frequency	Remedy
Image drum	3.71" (94.2mm)	Replace or clean the image drum cartridge.
Developing roller	1.86" (47.12mm)	Replace the image drum cartridge.
Toner supply roller	2.96" (75.27mm)	Replace the image drum cartridge.
Charging roller	1.21" (30.63mm)	Replace the image drum cartridge.
Cleaning roller	0.93" (23.56mm)	Replace the image drum cartridge.
Transfer roller	1.95" (49.6mm)	Replace the transfer roller.
Heat roller	2.44" (62.0mm)	Replace the fusing unit assy.
Back-up roller	2.73" (69.4mm)	Replace the back-up roller.

Note: After replacing the image drum cartridge, reset the drum counter by clicking the "Reset" button in the Status Monitor. (See Printer Handbook).

⑥ Prints voids

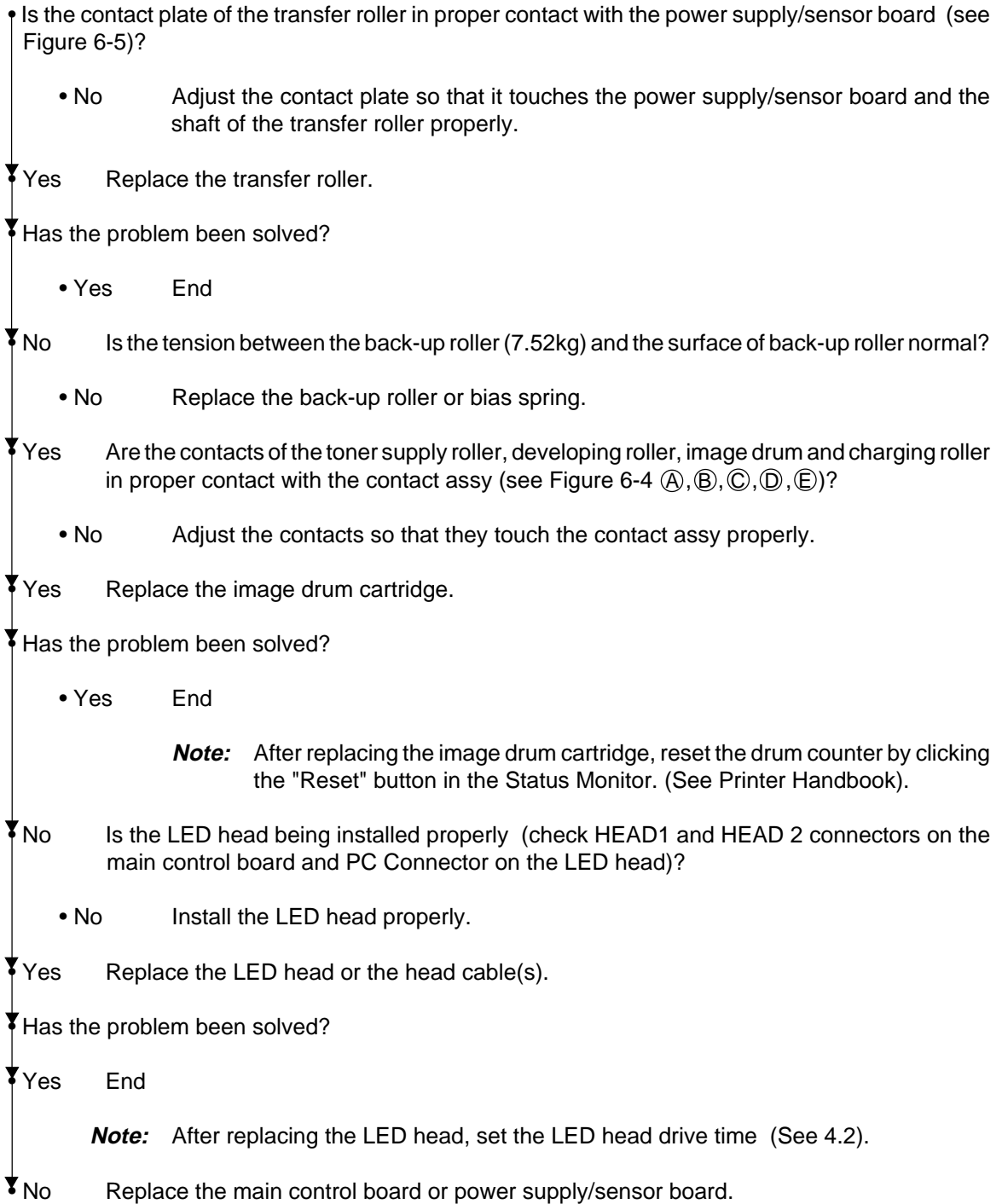

⑦ Poor fusing (images are blurred or peels off when the printed characters and images on the paper are touched by hand)

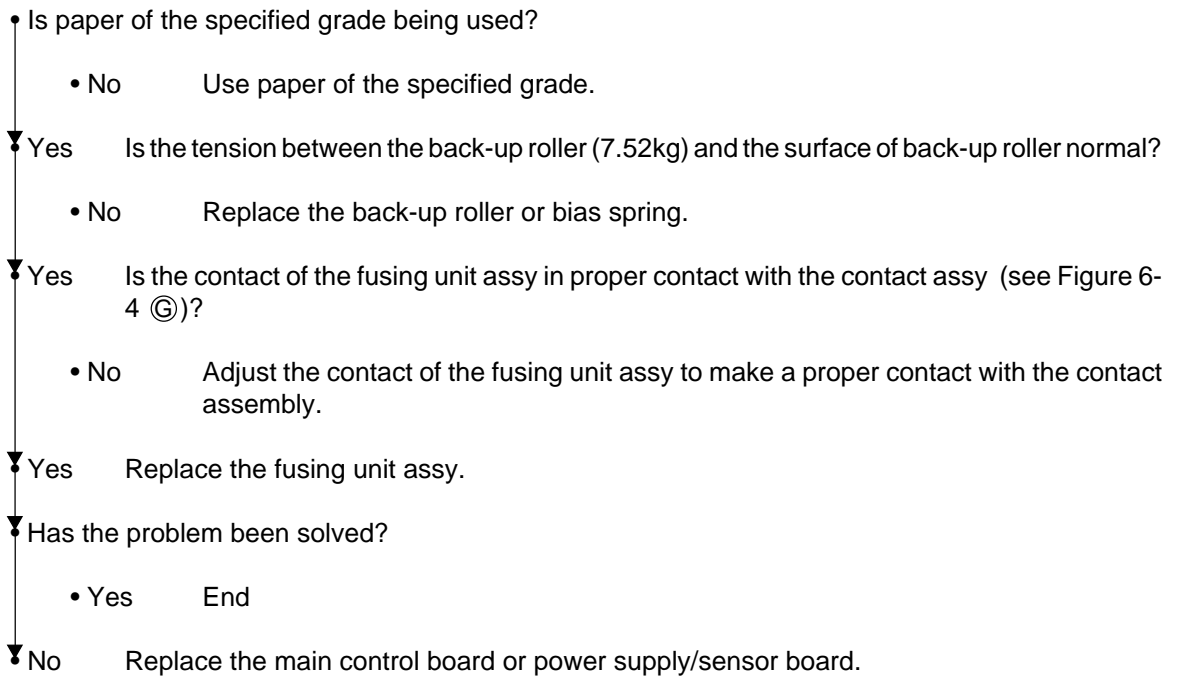

⑧ White vertical belts or streaks

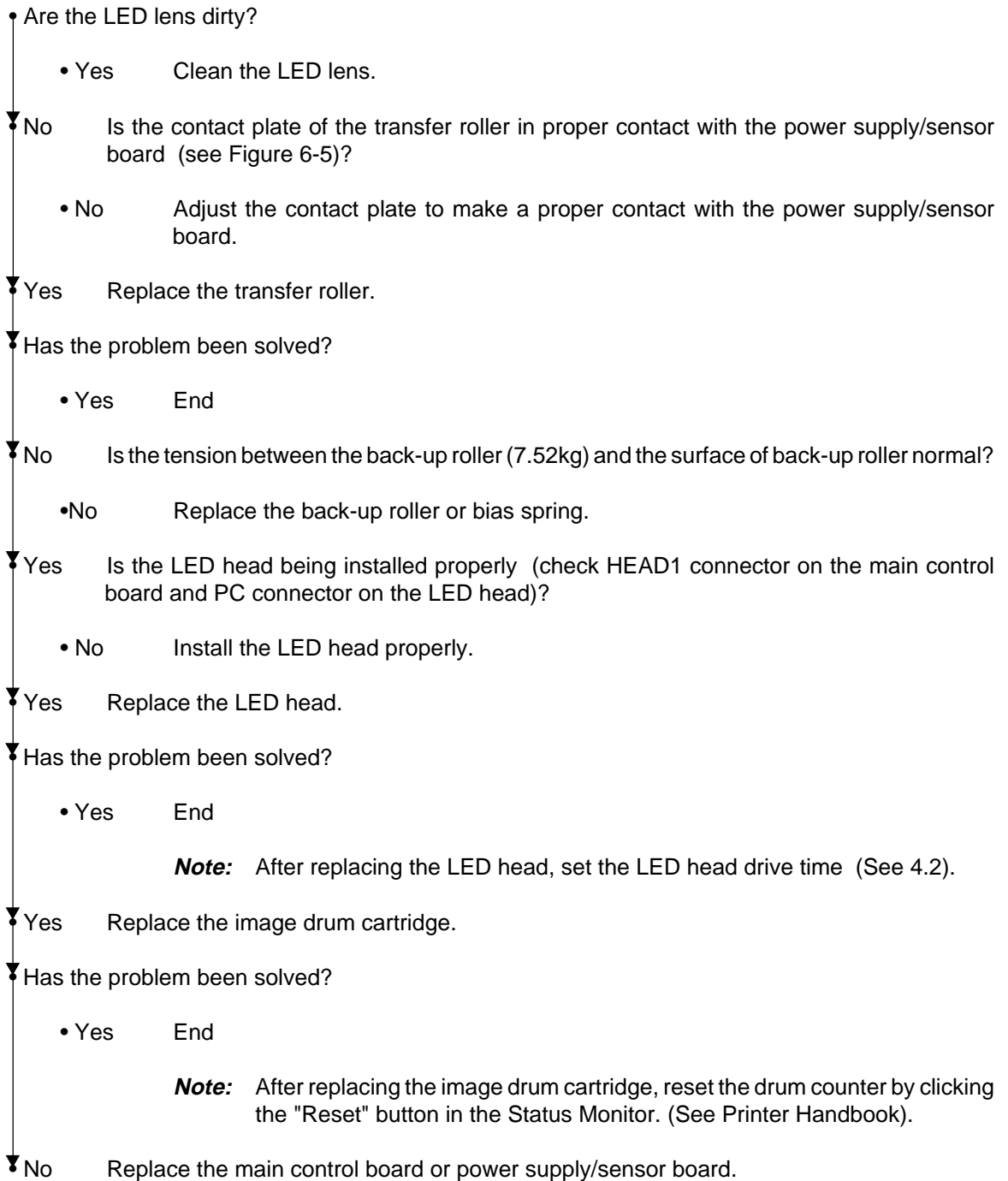

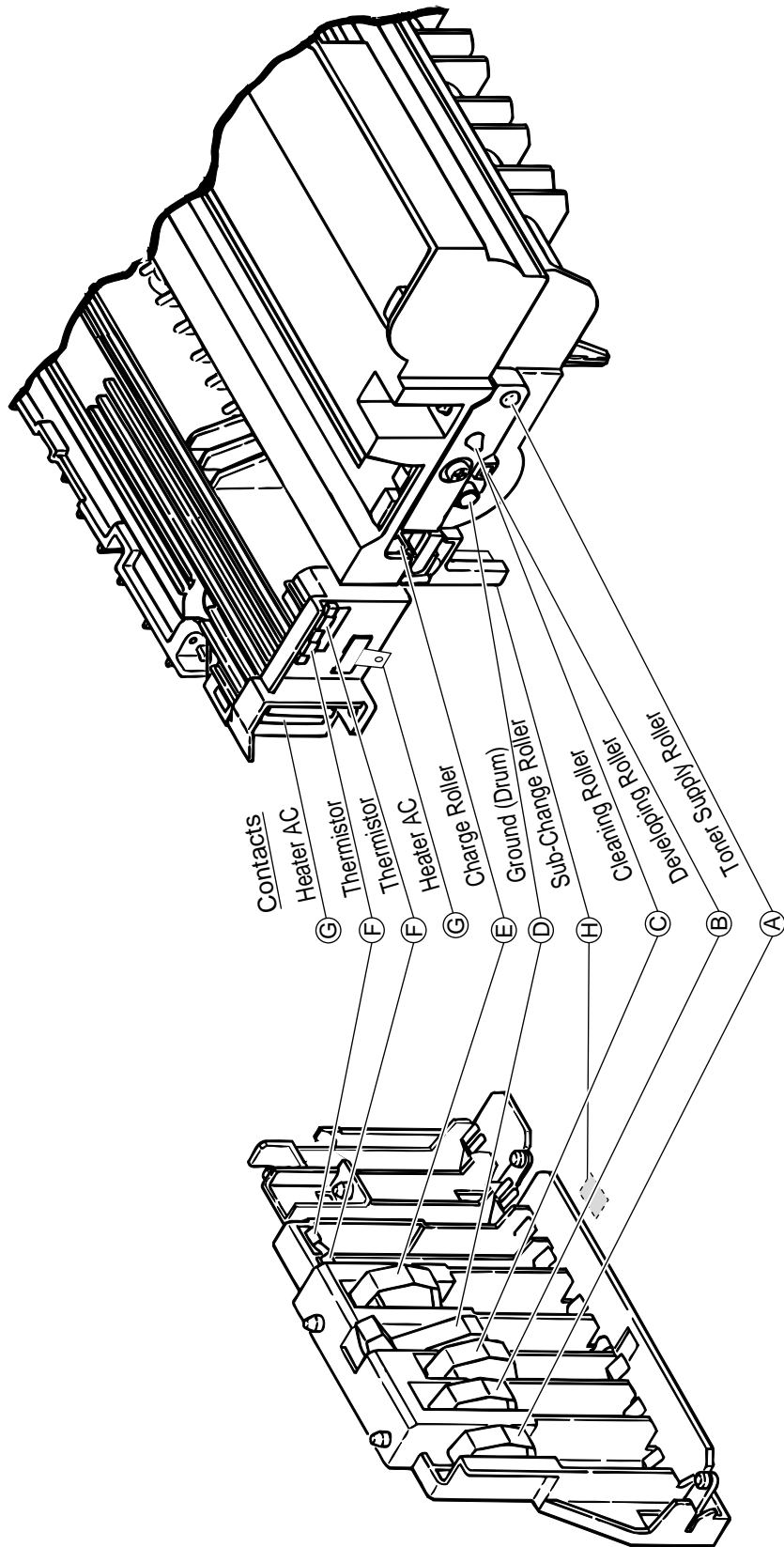

Figure 6-4

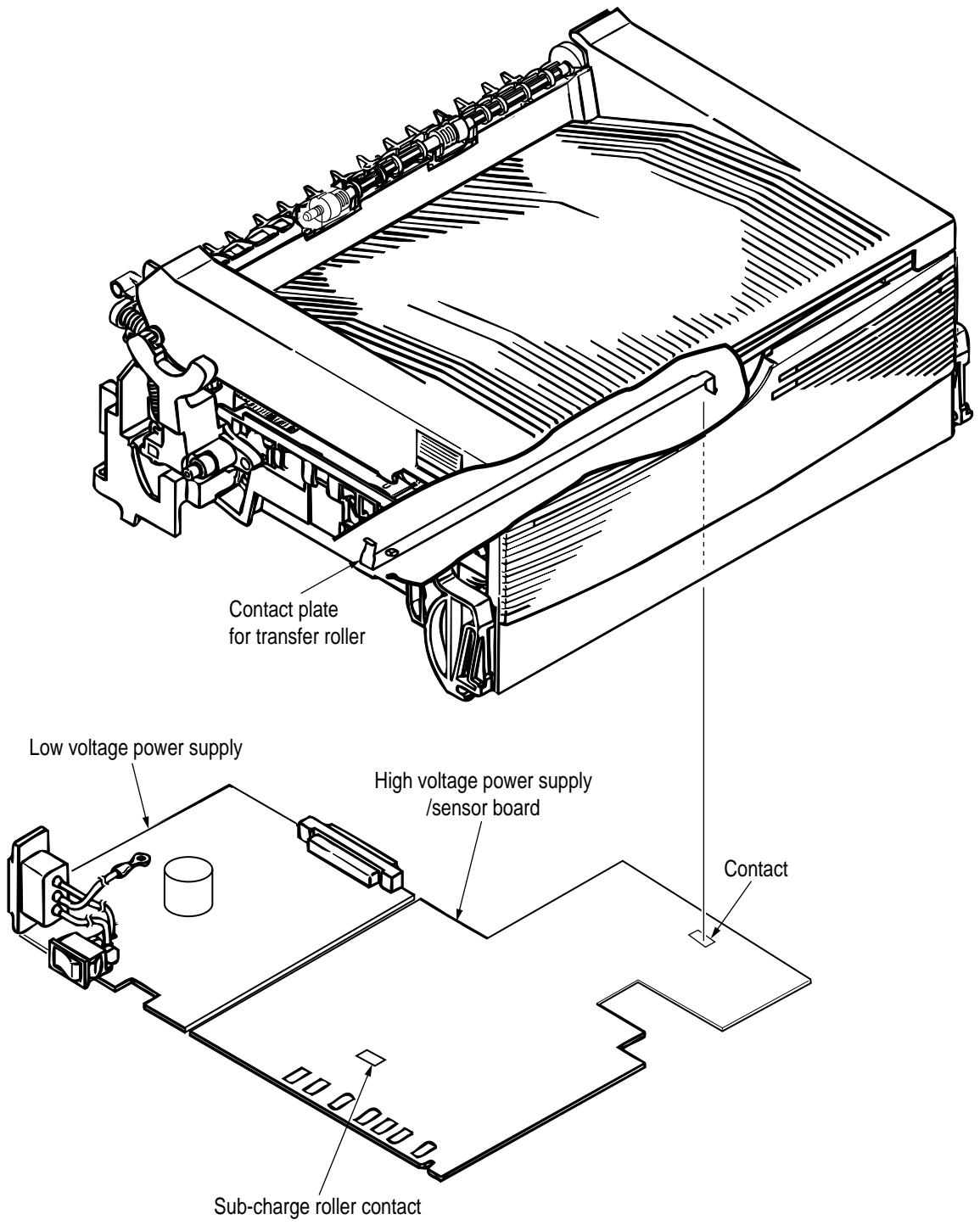
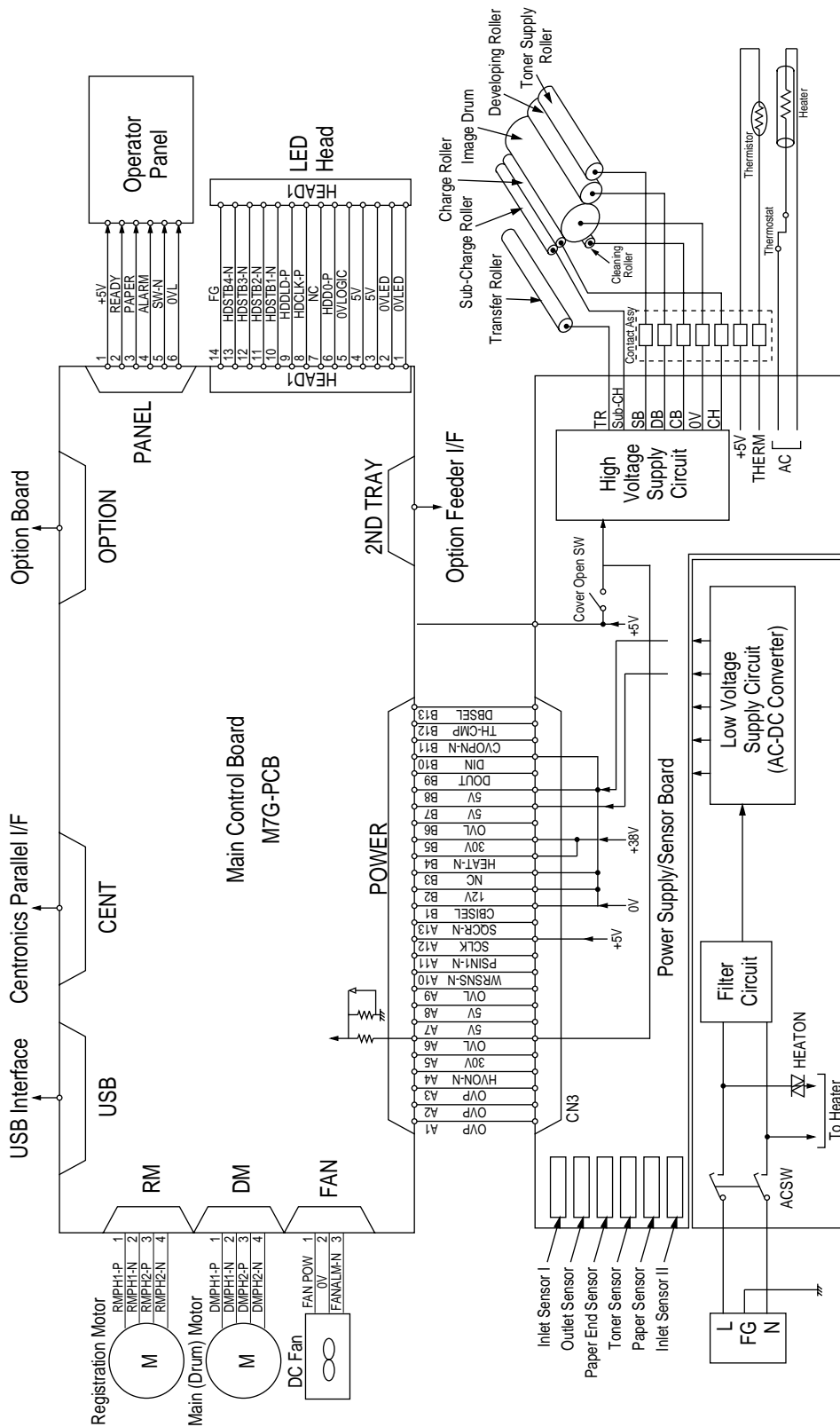

Figure 6-5

7. WIRING DIAGRAM

7.1 Interconnect Signal Diagram



7.2 PCB Layout and Connector Signal List

(1) Main Control Board (M7G-PCB)

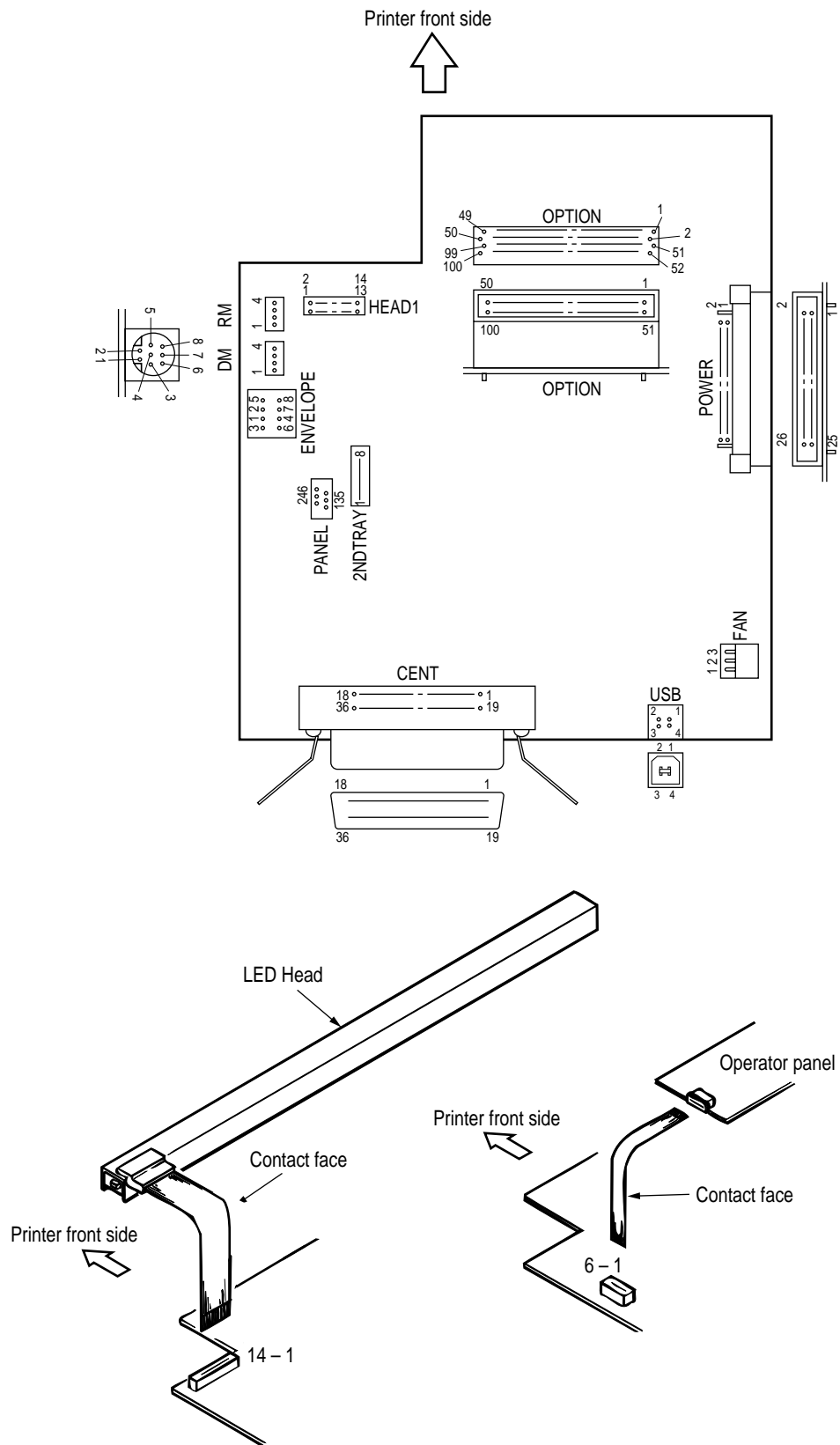

(2) Power Supply/Sensor Board

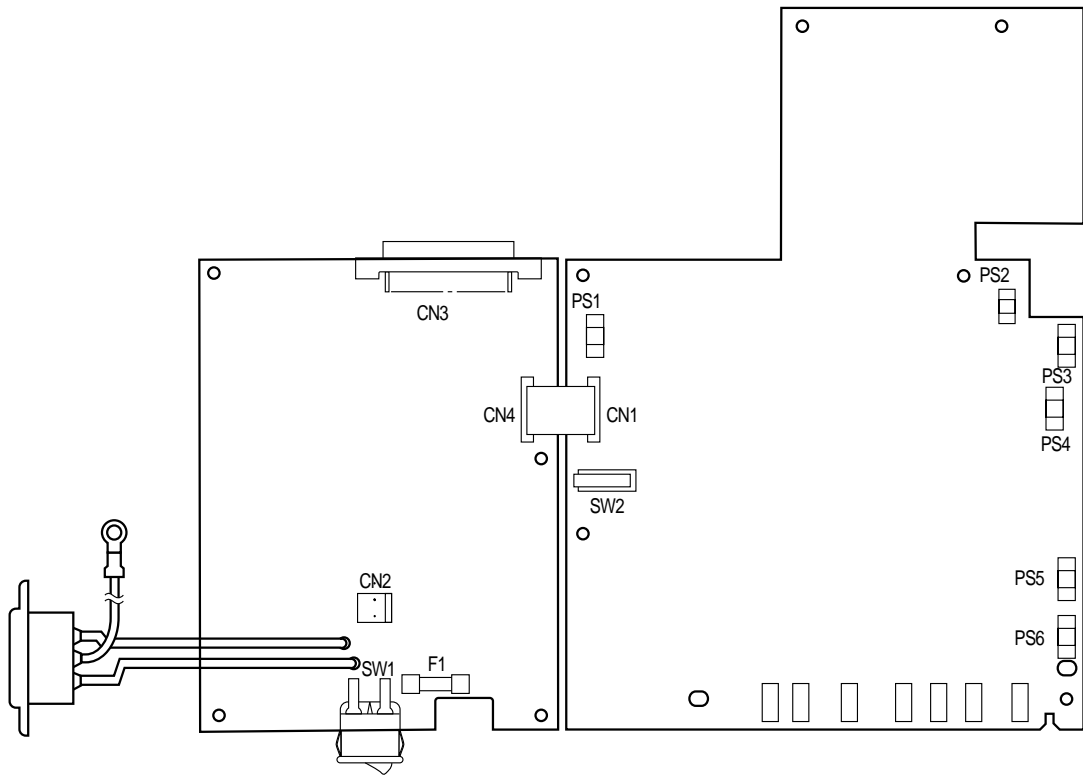

- FAN Connector Pin Assignment
(To fan motor)

		PIN NO.	I/O*	Signal	Description
Opening	1	1	O	FANPOW	Power supply for fan driving
	2	2	C	OV	Ground
	3	3	I	FANALM-N	Fan alarm

- DM Connector Pin Assignment
(To main/drum motor)

		PIN NO.	I/O*	Signal	Description
1	1	O	DMPH1-P	Coil 1-P	
2	2	O	DMPH1-N	Coil 1-N	
3	3	O	DMPH2-P	Coil 2-P	
4	4	O	DMPH2-N	Coil 2-N	

Excitation sequence

PIN NO.	Line Color	Step No.			
		1	2	3	4
2	Yellow	+	-	-	+
4	Black	+	+	-	-
1	Orange	-	+	+	-
3	Brown	-	-	+	+

Rotary direction Clockwise viewed from the output axis.

* I: In
O: Out
C: Common

- RM Connector Pin Assignment
(To registration motor)

	PIN NO.	I/O*	Signal	Description
1	1	O	RMPH1-P	Coil 1-P
2	2	O	RMPH1-N	Coil 1-N
3	3	O	RMPH2-P	Coil 2-P
4	4	O	RMPH2-N	Coil 2-N

* I: In
O: Out

Excitation sequence

PIN NO.	Line Color	Step No.			
		1	2	3	4
2	Yellow	+	-	-	+
4	Black	+	+	-	-
1	Orange	-	+	+	-
3	Brown	-	-	+	+

Rotary direction

Clockwise viewed from the output axis.

- HEAD1 Connector Pin Assignment
(To LED head)

		PIN NO.	I/O*	Signal	Description
14		14	C	FG	Flame Ground
	13	13	O	HDSTB4-N	Strobe4
12		12	O	HDSTB3-N	Strobe3
	11	11	O	HDSTB2-N	Strobe2
10		10	O	HDSTB1-N	Strobe1
	9	9	O	HDDL-D-P	Load
8		8	O	HDCLK-P	Clock
	7	7	N/C		
6		6	O	HDD0-P	Data0
	5	5	C	0VLOGIC	Logic Ground
4		4	C	5V	5V power supply for LED driving
	3	3	C	5V	5V power supply for LED driving
2		2	C	0VLED	Ground for LED
	1	1	C	0VLED	Ground for LED

* O: Out
C: Common

- PANEL Connector Pin Assignment
(To operator panel)

		PIN NO.	I/O*	Signal	Description
1		1	C	+5V	+5V power supply
	2	2	O	READY	Signal for READY
3		3	O	PAPER	Signal for PAPER
	4	4	O	ALARM	Signal for ALARM
5		5	I	SW-N	Signal for Switch
	6	6	C	0VL	Ground

* I: In
O: Out
C: Common

- ENVELOPE Connector Pin Assignment
(To option feeder I/F)

5	8
2	7
1	4
3	6

PIN NO.	I/O*	Signal	Description
1	O	PAPERIN-N	Paper sense 1
2	O	OPTSCLK-N	Clock
3	O	DATA-N	Data
4	I	PAPERIN-N	OPT send data ready
5	C	OVP	Analog ground
6	O	38V	+38V power supply
7	C	0V	Logic ground
8	O	5V	+5V power supply

* I: In
O: Out
C: Common

- 2ND TRAY Connector Pin Assignment
(To option tray I/F)

1
2
3
4
5
6
7
8

PIN NO.	I/O*	Signal	Description
1	O	PAPERIN-N	Paper sense 1
2	O	OPTSCLK-N	Clock
3	O	DATA-N	Data
4	I	PAPERIN-N	OPT send data ready
5	C	OVP	Analog ground
6	O	38V	+38V power supply
7	C	0V	Logic ground
8	O	5V	+5V power supply

* I: In
O: Out
C: Common

- POWER Connector Pin Assignment
(To power supply/sensor board)

Pin No.	I/O*	Signal	Description	Pin No.	I/O*	Signal	Description
B13	O	DBSEL	DB control switch	A13	I	SQCR-N	Sequence clear signal of serial I/F
B12	I	THERMCMP-P	Heater temperature	A12	I	SCLK-N	Clock signal of serial I/F
B11	I	CVOPN-N	Cover open (+5V)	A11	I	PSIN1-N	Paper sense
B10	O	DIN	Serial data output	A10	I	WRSNS-N	Reading of paper edge
B9	I	DOUT	Serial data input	A9	C	OVL	Ground for logic
B8	I	+5V	Logic circuit supply voltage	A8	I	+5V	Logic circuit supply voltage
B7	I	+5V	LED head supply voltage	A7	I	+5V	LED head supply voltage
B6	C	OVL	Logic ground	A6	C	OVL	Logic ground
B5	I	+30V	Motor and fan drive voltage and source voltage for high voltage supply	A5	I	+30V	Motor and fan drive voltage and source voltage for high voltage supply
B4	O	HEAT-N	Heater on	A4	O	HVON-N	Reset signal
B3	I		NC	A3	C	OVP	Analog
B2	I	+12V	High voltage Supply	A2	C	OVP	Analog
B1	O	CBISEL	CB control switch	A1	C	OVP	Analog

* O : Out

I : In

C : Common

- CENT Connector Pin Assignment
(To Centro parallel I/F)

Pin No.	I/O*	Signal	Description	Pin No.	I/O*	Signal	Description
1	I	STROBE-N	Strobe	19	C	SG	Ground
2	C	DATA1-P	Data bit 0	20	C	SG	Ground
3	C	DATA2-P	Data bit 1	21	C	SG	Ground
4	C	DATA3-P	Data bit 2	22	C	SG	Ground
5	C	DATA4-P	Data bit 3	23	C	SG	Ground
6	C	DATA5-P	Data bit 4	24	C	SG	Ground
7	C	DATA6-P	Data bit 5	25	C	SG	Ground
8	C	DATA7-P	Data bit 6	26	C	SG	Ground
9	C	DATA8-P	Data bit 7	27	C	SG	Ground
10	O	ACK-N	Acknowledge	28	C	SG	Ground
11	O	BUSY-P	Busy	29	C	SG	Ground
12	O	PE-P	paper end	30	C	SG	Ground
13	O	SEL-P	Select	31	I	IPRIME-N	Input prime
14	I	AUTOFEED-N	Auto feed	32	O	FAULT-N	Fault
15		NC	Not connected	33	C	SG	Ground
16	C	SG	Ground	34		NC	Not connected
17	C	FG		35	O	HILEVEL	Always kept high
18	O	P-LOGIC-H	+5V power supply	36	I	SELIN-N	Select in

* O: Out
I: In
C: Common

- USB Connector Pin Assignment
(To USB I/F)

2	1
3	4

PIN NO.	I/O*	Signal	Description
1	I	Vcc	+5V Power
2	I/O	D-	USB Data
3	I/O	D+	USB Data
4	C	0V	Ground

* I: In
O: Out
C: Common

- OPTION Connector Pin Assignment
(To option RAM or RS232C board)

01		51	
	02		52
03		53	
	04		54
05		55	
	06		56
07		57	
	08		58
09		59	
	10		60
11		61	
	12		62
13		63	
	14		64
15		65	
	16		66
17		67	
	18		68
19		69	
	20		70
21		71	
	22		72
23		73	
	24		74
25		75	
	26		76
27		77	
	28		78
29		79	
	30		80
31		81	
	32		82
33		83	
	34		84
35		85	
	36		86
37		87	
	38		88
39		89	
	40		90
41		91	
	42		92
43		93	
	44		94
45		95	
	46		96
47		97	
	48		98
49		99	
	50		100

* O: Out
I: In
C: Common

Pin No.	I/O*	Signal	Description	Pin No.	I/O*	Signal	Description
01	O	A0	OR write enable	51	I/O	D16	Data bit 16
02	C	0V	Logic ground	52	I/O	D0	Data bit 0
03	O	A1	Address bit 1	53	I/O	D17	Data bit 17
04	O	A2	Address bit 2	54	I/O	D1	Data bit 1
05	O	RS232C Data terminal ready	RS232C Data terminal ready	58	I/O	D18	Data bit 18
06	O	A3	Address bit 3	56	I/O	D2	Data bit 2
07	O	A4	Address bit 4	57	I/O	D19	Data bit 19
08	C	0V	Logic ground	58	I/O	D3	Data bit 3
09	O	A5	Address bit 5	59	I/O	D20	Data bit 20
10	O	A6	Address bit 6	60	I/O	D4	Data bit 4
11	O	+5V	Logic power supply	61	I/O	D21	Data bit 21
12	O	A7	Address bit 7	62	I/O	D5	Data bit 5
13	O	A8	Address bit 8	63	I/O	D22	Data bit 22
14	C	0V	Logic ground	64	I/O	D6	Data bit 6
15	O	A9	Address bit 9	65	I/O	D23	Data bit 23
16	O	A10	Address bit 10	66	I/O	D7	Data bit 7
17	O	+5V	Logic power supply	67	I/O	D24	Data bit 24
18	O	A11	Address bit 11	68	I/O	D8	Data bit 8
19	O	A12	Address bit 12	69	I/O	D25	Data bit 25
20	C	0V	logic ground	70	I/O	D9	Data bit 9
21	O	A13	Address bit 13	71	I/O	D26	Data bit 26
22	O	A14	Address bit 14	72	I/O	D10	Data bit 10
23	O	+5V	Logic power supply	73	I/O	D27	Data bit 27
24	O	A15	Address bit 15	74	I/O	D11	Data bit 11
25	O	A16	address bit 16	75	I/O	D28	Data bit 28
26	C	0V	Logic ground	76	I/O	D12	Data bit 12
27	O	A17	Address bit 17	77	I/O	D29	Data bit 29
28	O	A18	Address bit 18	78	I/O	D13	Data bit 13
29	O	+5V	Logic power supply	79	I/O	D30	Data bit 30
30	O	A19	Address bit 19	80	I/O	D14	Data bit 14
31	O	A20	Address bit 20	81	I/O	D31	Data bit 31
32	C	0V	Logic ground	82	I/O	D15	Data bit 15
33	O	A21	Address bit 21	83	O	DRAS2-N	DRAM select 2
34	O	A22	Address bit 22	84	O	DRAS3-N	DRAM select 3
35	O	A23	Address bit 23	85	O	DRAS4-N	DRAM select 2
36	O	0V	Logic ground	86	O	DRAS5-N	DRAM select 5
37	O	0V	Logic ground	87	O	DCAS3-N	DCAS3
38	C	0V	Logic ground	88	O	DCAS2-N	DCAS2
39	O	RS232C request to send	RS232C request to send	89	O	DCAS1-N	DCAS1
40	O	CS00N	For Debug mode	90	O	DCAS0-N	DCAS0
41	O	CS2-N	ROM/SRAM select 2	91	O	RD-N	RD-N
42	O	CS3-N	ROM/SRAM select 3	92	O	WR-N	WR-N
43	I	SCRREQ-P	SCC send request	93	I	INT1-N	Interrupt request 1
44	C	0V	Logic ground	94	I	INT2-N	Interrupt request 2
45	I	SCSREQ-P	SCC receive request	95	O	EEPRMCS1-P	EEPROM select
46	O	IOS0-N	I/O select 0	96	O	EEPRMCLK-P	EEPROM clock
47	O	IOS1-N	I/O select 1	97	C	SSTXD-P	EEPROM data
48	O	RSTXD0-N	RS232C send data	98	I	DRDY-N	Data read
49	O	NC	RS232C line voltage	99	C	+12V	RS232C line voltage
50	I	RSRXD0-P	RS232C receive data	100	O	RESET-N	Reset signal

7.3 Resistance Check

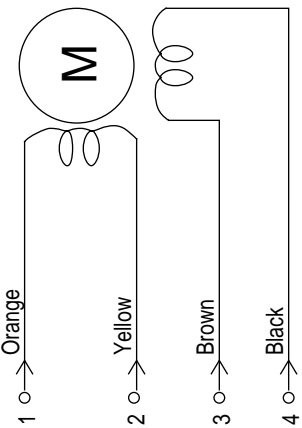
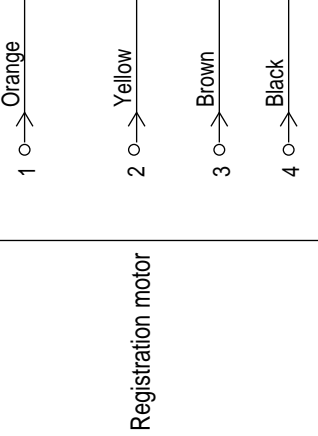
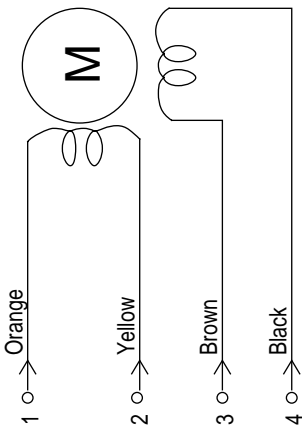
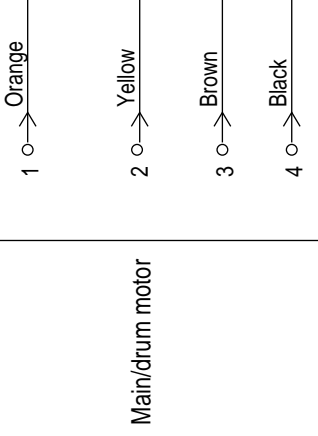
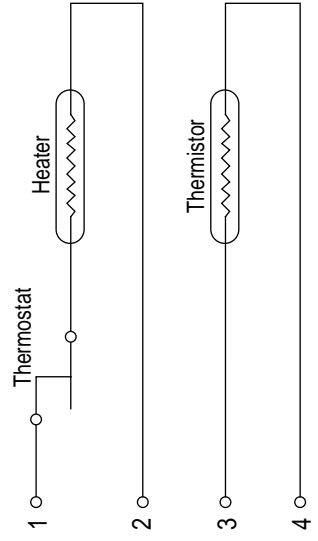
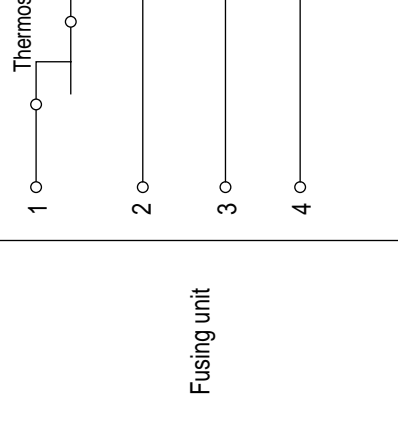
Unit	Circuit Diagram	Illustration	Resistance
Registration motor			<p>Between Pins 1 and 2: 9.5Ω Between Pins 3 and 4: 9.5Ω</p>
Main/drum motor			<p>Between Pins 1 and 2: 4.2Ω Between Pins 3 and 4: 4.2Ω</p>
Fusing unit			<p>Between Pins 1 and 2: 120V 3Ω 240V 10Ω Between Pins 3 and 4: 220KΩ (at room temperature)</p>

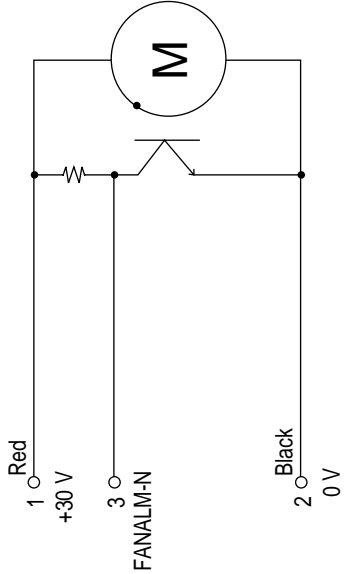
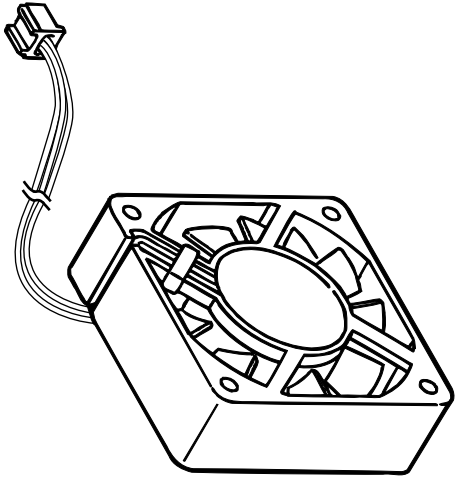
Unit	Circuit Diagram	Illustration	Resistance
Fan	 <p>1 Red +30 V</p> <p>3 FANALM-N</p> <p>2 Black 0 V</p>		

8. PARTS LIST

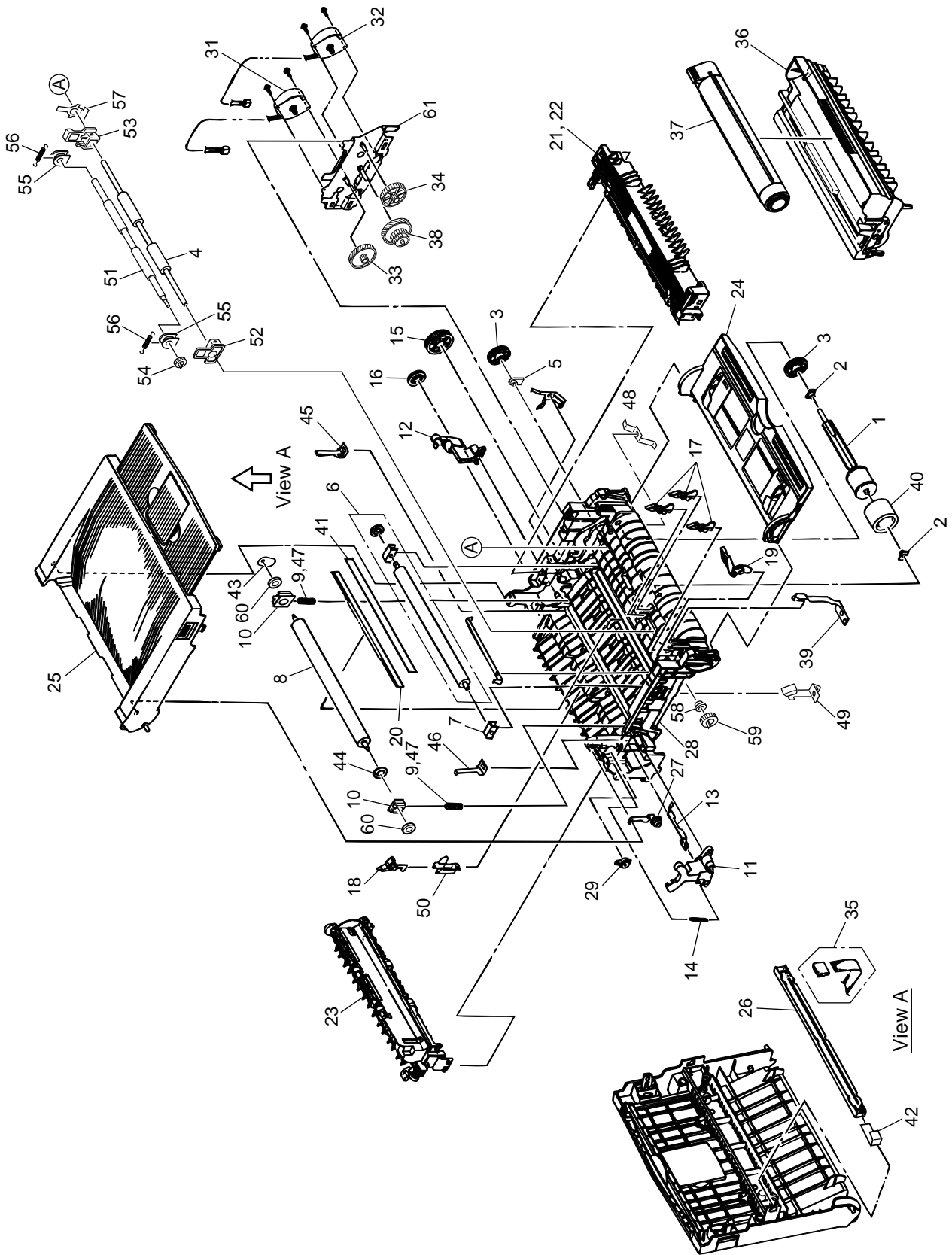

Figure 8-1 Lower Base Unit

Table 8-1 Lower Base Unit (1/2)

No.	Name/Rating	Part No.	Use	Remarks	ODA Part No.
1	Hopping roller shaft	3PP4083-6020P001	1		51112601
2	Bearing	4PP4083-6022P002	2		51607402
3	Hopping roller one-way clutch gear	4PB4083-6024P001	2		51228901
4	Roller registration	41281101	1		
5	Bearing (registration)	4PP4083-6031P001	1		51607501
6	Roller-Transfer Assy	40437802	1		
7	Bearing TR	40438001	1		
8	Roller Back-up	41301801	1		
9	Spring Bias	41584101	2		
10	Holder BU	41536201	2		
11	Reset lever L	40581801	1		50805801
12	Reset lever R	3PP4083-6054P001	1		50805901
13	Cover open switch arm	3PP4083-6058P001	1		53068901
14	Stacker cover reset spring	4PP4083-6057P001	1		50924201
15	Fuser roller idle gear	4PP4083-6080P001	1		51229101
16	Eject roller idle gear	4PP4083-6081P001	1		51229201
17	Sensor plate (inlet)	4PP4083-6083P001	3		51010701
18	Lever eject sensor Assembly	40771401	1		
19	Toner sensor (adhesion)	4PP4083-6086G001	1		50405501
20	Diselectrification bar	4PB4083-6979P001	1		
21	Heat Assy - OP14i	40470107	1	120V	
22	Heat Assy - OP14i	40470108	1	230V	
23	Roller assy - Eject	40772501	1		
24	Manual feed guide assy	2PA4128-1149G001	1		51011001
25	Stacker-Assy	40103803	1		
26	LED head unit - 31E	41673601	1		
27	Stacker cover damper arm	4PP4083-6191G001	1		53069101
28	Frame subassy	41453901	1		
29	Stacker cover damper	4PB4083-6197P001	1		51229401
30					
31	Motor-Pulse (main)	41301901	1		
32	Motor-Pulse (regist)	40722301	1		
33	Gear-Idle A (Z60/20)	41279001	1		
34	Gear-Idle B (Z45/16)	41279101	1		
35	Cord-LED Assembly	41669801	1		
36	Image drum unit	41331601	1	ODA	
	Image drum unit	41331602	1	OEL	
	Image drum unit	41331603	1	APS	
37	Toner Cartridge	40433203	1	APS(2.5k)	
38	Gear-Reduction	41279201	1		
39	FG plate (O.P.)	4PP4083-7663P001	1		
40	Hopping roller rubber	4PB4076-5447P001	1		
41	Diselectrification Film	3PB4083-6089P001	1		

Table 8-1 Lower Base Unit (2/2)

No.	Name/Rating	Part No.	Use	Remarks	ODA Part No.
42	LED Contact	4PP4083-6173P001	1		
43	Washer C	4PP4120-1210P001	1		
44	Washer B	4PP4120-1209P001	1		
45	Spacer-Bearing R	41583901	1		
46	Spacer-Bearing L	41584001	1		
47	Bias spring A	41599601	2	Special parts for envelope *	
48	Plate-Contact PB	41280501	1		
49	Plate-Contact CH-Sub	41280201	1		
50	Sensor wire Assembly	41027701	1		
51	Roller-Pressure	41281001	1		
52	Holder-Regist L	41279501	1		
53	Holder-Regist R	41279601	1		
54	Gear-Pressure	41279801	1		
55	Bearing-Pressure	41279401	2		
56	Spring-Tension	41281201	2		
57	Plate-Contact PA	41280401	1		
58	Bearing-Regist L	41279301	1		
59	Gear-Regist	41279701	1		
60	Bearing-Ball	41584201	2		
61	Bracket-Motor	41280001	1		

* This part is countermeasure for envelope wrinkle and common part to bias spring A in OL400e. Both side springs must be exchanged at the same time.

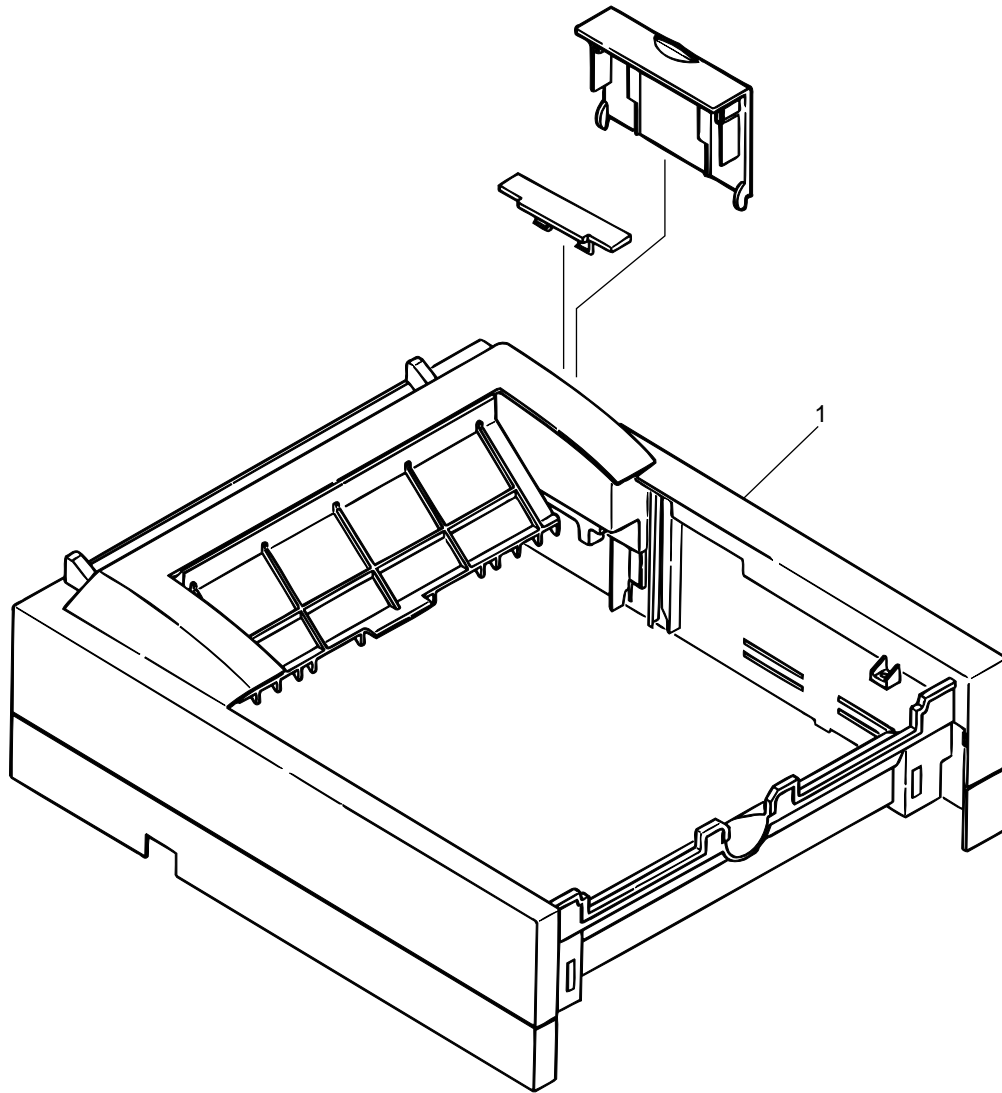

Figure 8-2 Upper cover unit

Table 8-2 Upper cover unit

No.	Name/Rating	Part No.	Use	Remarks	ODA Part No.
1	Upper cover assy	41618801	1		

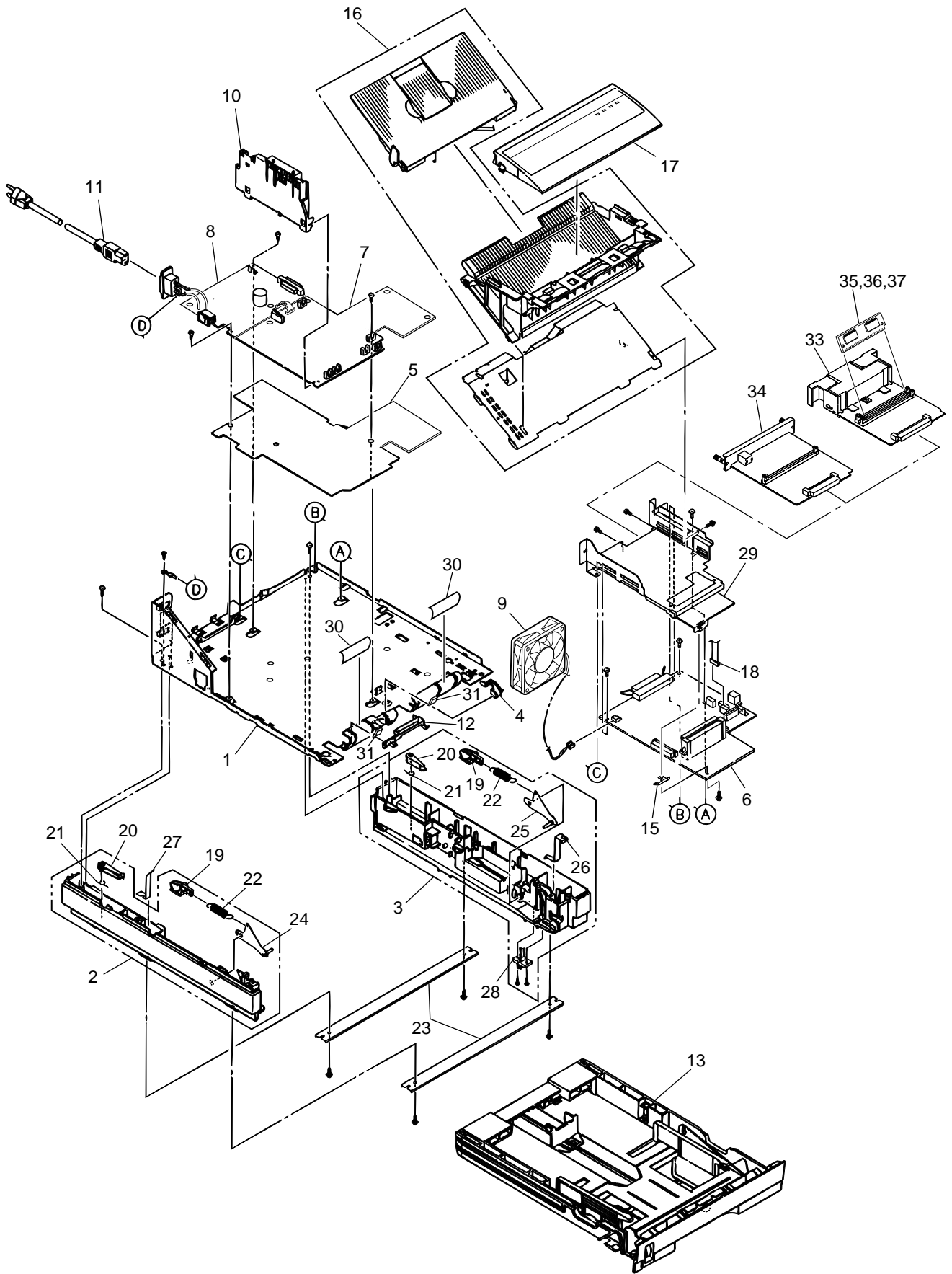

Figure 8-3 Base unit

Table 8-3 Base unit

No.	Name/Rating	Part No.	Use	Remarks	ODA Part No.
1	Plate base	41279901	1		
2	Cassette guide (L) assy	3PP4083-7670G001	1		51011201
3	Cassette guide (R) assy	3PP4083-7671G001	1		51011301
4	Sensor plate (paper supply)	4PP4083-7667P001	1		51011401
5	Plate-Insulator	41301601	1		
6	Board-M7G	41478603	1		
7	PCB Assy-HV1	41228501	1		
8	Power supply Unit	41533501	1	120V	
	Power supply Unit	41533601	1	230V	
9	Fan motor	41454401	1		
10	Contact assy	41445801	1		
11	AC cord	3YS4011-1315P001	1	120V	51011501
	AC cord	3YS4011-1266P001	1	220~240V	
12	Cassette sensor plate	3PP4083-6154P001	1		
13	Cassette Assy-Paper	40473006	1		
14					
15	Earth plate	4PP4083-6137P001	1		51011601
16	Face up stacker cover assy	2PA4128-1143G001	1		51011301
17	Frame Assy-OP Panel	40979704	1	ODA/OEL/INT	
18	Cord assy /OP	40997101	1	120V	
19	Link pull block	4PP4122-1170P001	2		
20	Cassette lock lever	3PP4083-7653P001	2		
21	Cassette lock lever spring	4PP4083-7655P001	2		
22	Sheet spring	4PP4083-7666P001	2		
23	Beam	3PP4083-7660P001	2		
24	Sheet link L assy	4PP4083-7657G001	1		
25	Sheet link R assy	4PP4083-7658G001	1		
26	FG plate (2nd)	4PP4083-7662P001	1		
27	FG plate (bm)	4PP4083-7665P001	1		
28	Connector cord	3YS4111-3527P001	1		
29	Plate Guide-PCB	41301701	1		
30	Polyethylene Tape	4YC4061-5115P001	2	L=91.5mm	
31	Guide-Paper H	40828301	2		
32	CS-RING(CS3-SUS)	4PB4013-3501P002	2		
33	Board-MM7	41204104	1	Option	
34	Board-SIF	41204704	1	Option	
35	Board-FSL	40405419	1	Option (4MB)	
36	Board-FSL	40405420	1	Option (8MB)	
37	Board-FS2	41155804	1	Option	

Appendix A RS-232C SERIAL INTERFACE (option)

1) Connector

- Printer side : 25-pin receptacle
Type DB-25S (made by Canon) or equivalent
- Cable side : 25-pin plug
Type DB-25S (made by Canon)
Shell
Type DB-C8-J10-F2-1 (made by Nihon Kouku Denshi) or equivalent

Note: Plug shall be fixable with a lock screw.

2) Cable

- Cable length : 6 ft (1.8 m) max. (cable shall be shielded)

Note: Cable is not provided.

3) Interface signal

Pin No.	Signal name	Abbreviation	Signal direction	Functions
1	Frame Ground	FG		Frame Ground
2	Transmitted Data	TD	← PR	Transmitted Data
3	Received Data	RD	→ PR	Received Data
4	Request to Send	RTS	← PR	Stay space level
5	-			(Not connected)
6	-			(Not connected)
7	Signal Ground	SG		Signal Ground
9	-			(Not connected)
17	-			(Not connected)
18	-			(Not connected)
19	-			(Not connected)
20	Data Terminal Ready	DTR	← PR	Data terminal ready
21	-			(Not connected)
25	-			(Not connected)

- Connector pin arrangement

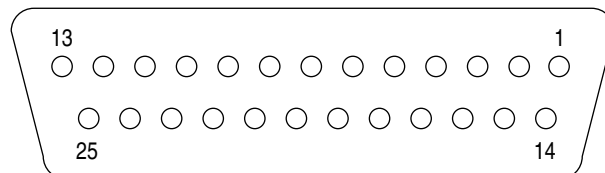

(View from the cable side)

When the Ready/Busy protocol is used for the buffer busy control method, the busy signal can be set to Pin-20 (DTR) in the menu.

4) Signal Level

- MARK polarity : -3V to -15V (LOGIC = 1)
- SPACE polarity : +3V to +15V (LOGIC = 0)

5) Interface Circuit

a) Receiving Circuit

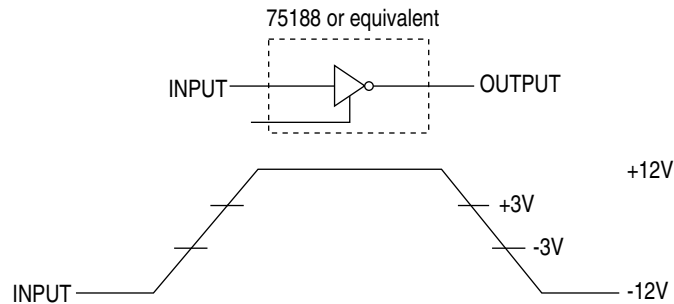

b) Sending Circuit

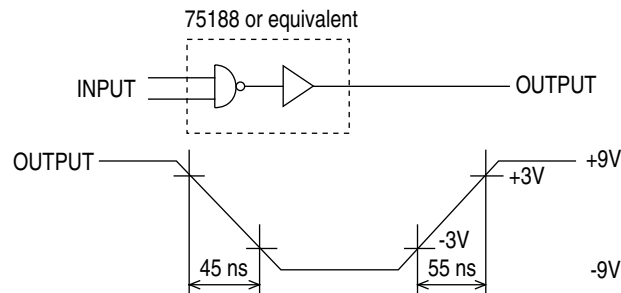

Note: The signal levels described above is for the case where $3K \Omega \times 15pF$ is connected to the terminal.

6) Receive Margin

37% min. at all reception rates.

7) Communications Protocol

- READY/BUSY protocol
- X-ON/X-OFF protocol

8) Interface Parameter Setting

When the option RS232C board is mounted, the following settings are possible by Dos soft operator panel. Refer to the Dos soft operator panel manual.

- Flow Control
- Baud Rate
- Bit length
- Parity

Appendix B CENTRONICS PARALLEL INTERFACE

1) Connector

- Printer side : 36-pin receptacle
(single port) Type 57RE-40360-730B-D29A (made by Daiichi Denshi), CN-AX05841A36AT (made by Ougat) or equivalent
- Cable side : 36-pin plug
Type 57-30360 (made by Daiichi Denshi) or equivalent
Plug-552274-1 (AMP), 552073-1 (AMP) or equivalent

2) Cable

- Cable length : 6 ft (1.8 m) max.
(A Shielded cable composed of twisted pair wires is recommended for noise prevention.)

Note: Cable is not supplied with the printer, and is not available from Oki.

3) Table of Parallel I/F Signals

Pin No.	Signal name	Signal direction	Functions
1	$\overline{\text{DATA STROBE}}$	→ PR	Parallel data sampling strobe
2	DATA BIT - 1		
3	DATA BIT - 2		
4	DATA BIT - 3		
5	DATA BIT - 4	→ PR	PR Parallel input and output data
6	DATA BIT - 5		
7	DATA BIT - 6		
8	DATA BIT - 7		
9	DATA BIT - 8		
10	$\overline{\text{ACKNOWLEDGE}}$	← PR	Completion of data input or end of a function
11	BUSY	← PR	During print processing or alarm
12	PAPER END	← PR	End of paper
13	SELECT	← PR	Select state (ON-LINE)
14	$\overline{\text{AUTOFEED}}$	→ PR	Request to change mode
15	-		(Not used)
16	0V		Signal ground
17	CHASSIS GROUND		Chassis ground
18	+5V	← PR	50 mA max.
19 ⋮ 30	0V		Signal ground
31	$\overline{\text{INPUT PRIME}}$	→ PR	Initializing signal
32	$\overline{\text{FAULT}}$	← PR	End of paper or during alarm
33	-		Signal ground
34	-		(Not used)
35	-		High level (3.3 kΩ)
36	$\overline{\text{SELECT IN}}$	→ PR	Request to change mode

- Connector pin arrangement

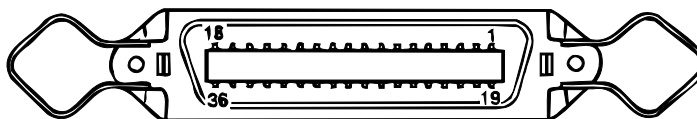

4) Signal Level

- LOW : 0 V to +0.8 V
- HIGH : +2.4 V to 5.0 V

5) Specifications

Item	Description
Mode	Compatibility mode, Nibble mode, ECP mode
Data bit length	8 bits (in the compatibility mode)
Input prime	Valid/Invalid
Receive buffer	8K, 20K, 50K, 100K, 1M Bytes
Control	Handshaking control is performed in each mode. Data received from the host is stored in the receive buffer. Busy control is performed. Signal lead control is performed.

6) Timing Charts

a) Data receiving timing

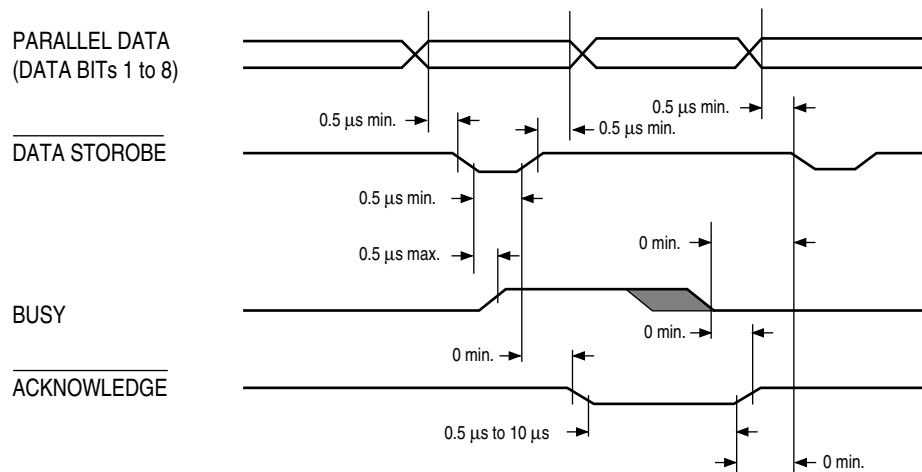

b) On-line → off-line switching timing by ON-LINE SW

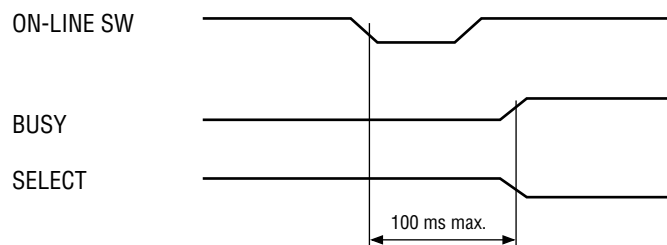

c) Off-line → on-line switching timing by ON-LINE SW

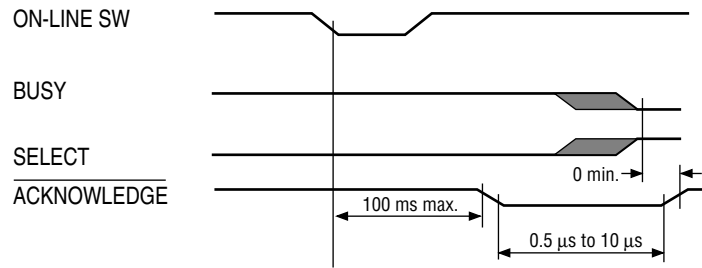

d) INPUT PRIME timing (when set to the effective INPUT PRIME signal)

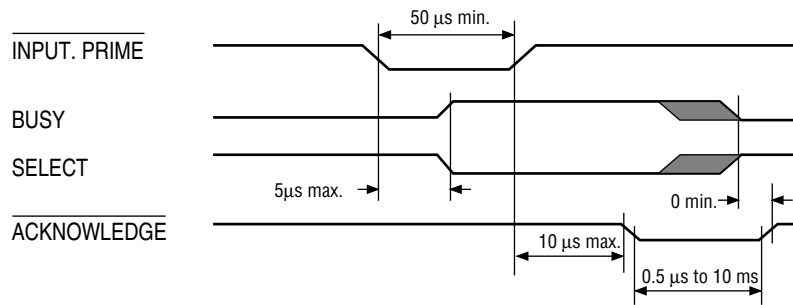

Appendix C UNIVERSAL SERIAL BUS (USB)

Universal Serial Bus Specification Revision 1.1 compliance.

1) Connector

- Printer Side : "B" Receptacle (Upstream Input to the USB Device)
- Cable Side : Series "B" Plug

2) Cable

- Cable Length : Max 5m (A cable must be met USB Spec Revision 1.1 for normal operation)

Note: Cable is not provided.

3) Table of USB I / F signals

Contact Number	Signal Name
1	Vbus
2	D -
3	D +
4	GND
Shell	Shield

4) Connector pin arrangement

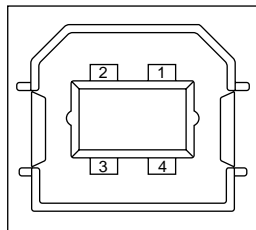

5) Mode & Class of Device

- Full - speed Driver
- Self - powered Device

6) Data Signaling Rate

- Full - speed function - 12Mb/s

7) Interface circuit

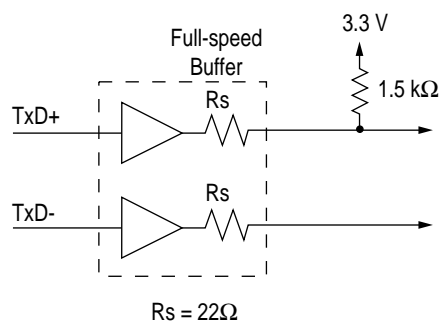

8) Signal Level

- Input / Output Level

Parameter	Symbol	Min.	Max.	Units
Input Levels :				
High (driven)	V _{IH}	2.0		V
High (floating)	V _{IHZ}	2.7	3.6	V
Low	V _{IL}		0.8	V
Output Levels :				
Low	OL	0.0	0.3	V
High (driven)	OH	2.8	3.6	V
Output Signal Crossover Voltage	V _{CRS}	1.3	2.0	V

- Signaling Levels

Bus State	Signaling Levels	
	Required	Acceptable
Differential "1"	(D+) - (D-) > 200mV and D+ > V _{IH} (min)	(D+) - (D-) > 200mV
Differential "0"	(D-) - (D+) > 200mV and D- > V _{IH} (min)	(D-) - (D+) > 200mV
Single-ended 0 (SE0)	D+ and D- < V _{IL} (max)	D+ and D- < V _{IH} (min)
Data J state:		
Low-speed	Differential "0"	
Full-speed	Differential "1"	
Data K state:		
Low-speed	Differential "1"	
Full-speed	Differential "0"	
Idle state:		
Low-speed	D- > V _{IHZ} (min) and D+ < V _{IL} (max)	D- > V _{IHZ} (min) and D+ < V _{IH} (min)
Full-speed	D+ > V _{IHZ} (min) and D- < V _{IL} (max)	D+ > V _{IHZ} (min) and D- < V _{IH} (min)
Resume state	Data K state	
Start-of-Packet (SOP)	Data lines switch from Idle to K state	
End-of-Packet (EOP)	SE0 for ≥ 1 bit time ¹ followed by a J state for 1 bit time	SE0 for ≥ 1 bit time ¹ followed by a J state
Disconnect (at downstream port)	SE0 for ≥ 2.5μs	
Connect (at downstream port)	Idle for ≥ 2ms	Idle for ≥ 2.5μs
Reset	D+ and D- < V _{IL} (max) for ≥ 10ms	D+ and D- < V _{IL} (max) for ≥ 2.5μs

Note: The width of EOP is defined in bit times relative to the device type receiving the EOP. The bit time is approximate.

9) Timing Chart

a) Packet Voltage Levels

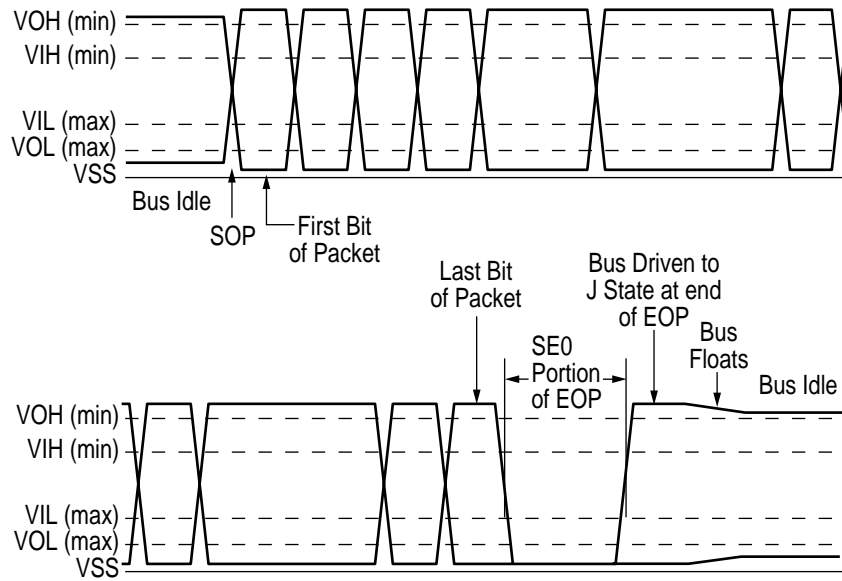

b) Disconnect Detection

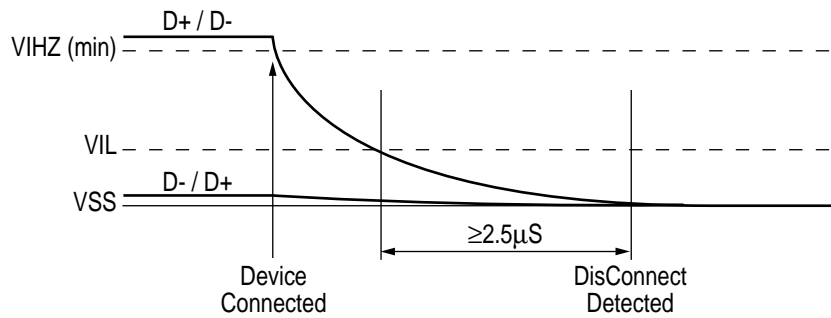

c) Full-speed Device Connect Detection

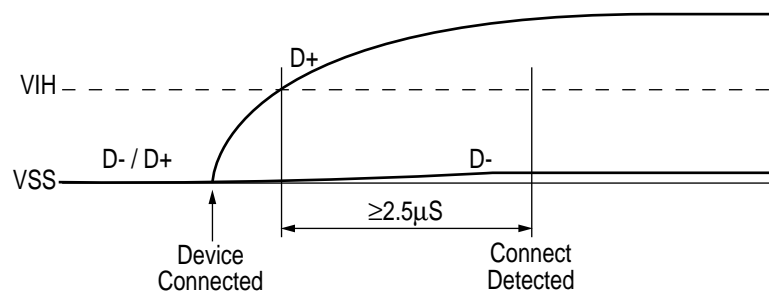

d) Differential Data Jitter

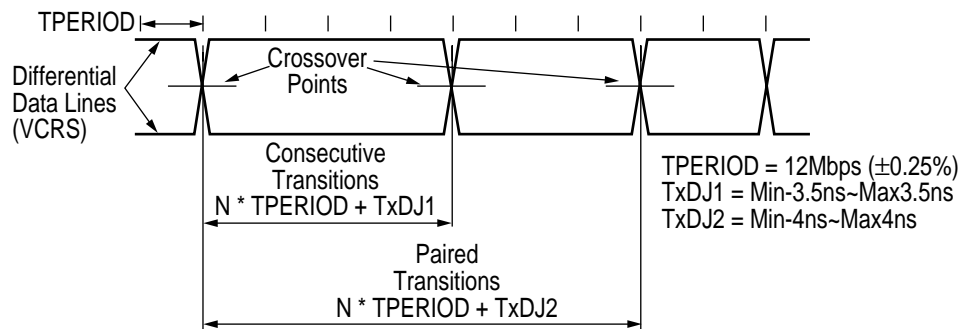

e) Differential-to-EOP Transition Skew and EOP Width

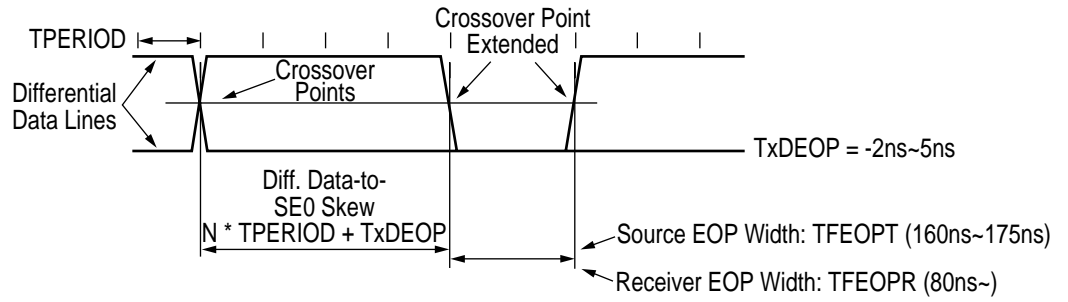

f) Receiver Jitter Tolerance

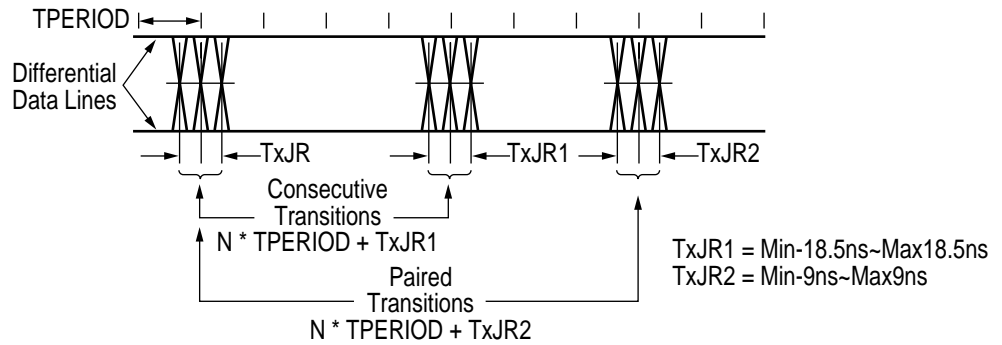

Appendix D MAINTENANCE UTILITY GUI MANUAL

1. Overview

This document provides detailed descriptions of the GUI, a maintenance utility corresponding to the PN248/PN249/PN151/PN257/PN59/PN254 series of printers.

1.1 System Requirements

OS: Japanese or English Windows95/98
RAM: Japanese 12 MB or more/ English 8 MB or more
HDD: 2 MB or more of Available Disk Space (Installed)
CPU: 486 or more
Monitor: 640 × 480 resolution

2. Utility Starting-Time Operation

The maintenance utility interprets environment setting languages based on the device IDs of connected printers and analyzes their commands.

Environment setting languages to be specified in the printers are as follows:

No.	ID Name of Applicable Model	Model Name	Environment Setting Language	Remark
1	OKIPAGE 8p Plus	PN248	PJL	
2	OKIPAGE 8w Plus	PN249	OPEL	
3	OKIPAGE 8w Lite	PN251	OPEL	
4	OKIPAGE 8z	PN251	OPEL	
5	OKIPAGE 8iM Plus	PN257	OPEL	
6	MOCROLINE 8wU	PN59	OPEL	
7	OKIPAGE 14e	PN254	PJL	

When the device ID of a connected printer is anything other than those of applicable models, the dialog to select an operating environment of the maintenance utility is displayed.

The environment setting language is determined to be OPEL if OPEL” is supported and, if this is not the case, managed as PJL according to each command set in the device ID.

The operating environment is selected by model name, based on each language (OPEL/PJL), from the combo box.

The utility runs only with “OKIPAGE 8w Plus” for OPEL and only with “OKIPAGE 8p Plus” for PJL at present.

Dialog for Selecting Operating Environment

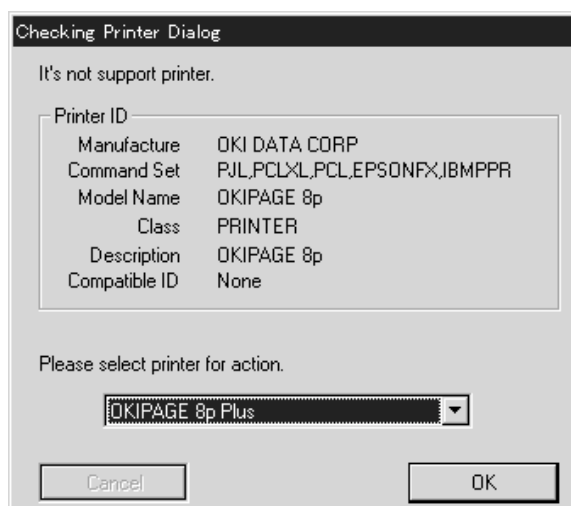

3. Main Set Property Sheet

The following example shows the main menu dialog display.

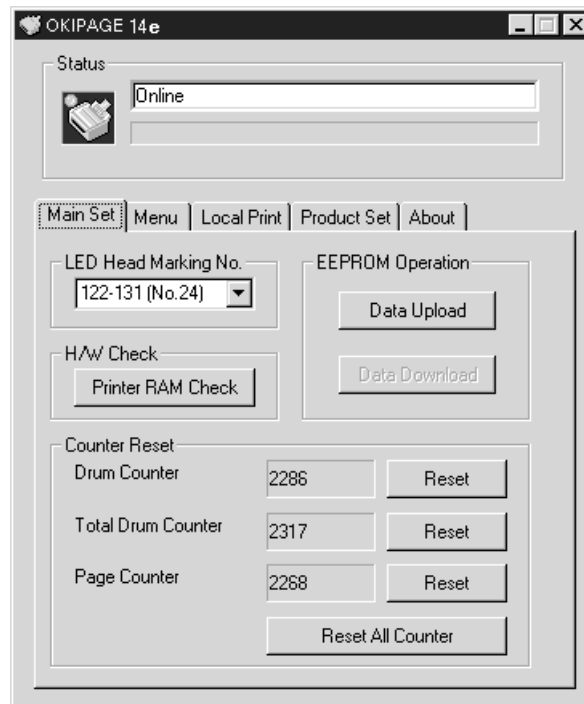

3.1 Printer Status Group

The printer status is supervised, and displayed in real time. A number at the beginning of the line indicates a status code transmitted from the printer side.

The following details the icons.

(The upper left green and red lamps show the off-line and on-line states, respectively.)



(Blue) Indicates the printer normal condition.



(Yellow) Indicates the printer error condition (recoverable).



(Red) Indicates the printer error condition (unrecoverable).

* Parenthesized letters show the icon color.

Printer Status List (Common to P JL and OPEL)

No.	Printer Status	PJL code	OPEL code	Status Message
1	LCD Check (Power On)	–	–	
2	Initializing	–	0000	Initializing
3	ON-LINE (Ready)	10001	0010	On-line
4	OFF-LINE	10002	0011	Off-line
5	Data Exist	10096	0012	Data Exist
6	Power Saving	10094	0020	Power Saving
7	Reset	10005	–	
8	Print Demo	10017	0030	Demo Printing
9	Print Menu	10014	0031	Menu Printing
10	Print Fonts	10015	0032	Font Printing
11	Print Cleaning	10089	–	
12	Toner Low	10006	1000	Toner Low
13	Toner Sensor Problem	10093	1001	Toner Sensor Error
14	Change Drum	10092	1002	Change Drum
15	Fuser Life	(10091)	–	
16	Raster Buffer RAM Check Error	–	1010	RAM Check Error
17	Manual Paper Out (Back ground)	111xx	–	
18	Tray1 Paper Out (Back ground)	112xx	–	
19	Tray2 Paper Out (Back ground)	113xx	–	
20	Feeder Paper Out (Back ground)	114xx	–	
21	Manual Paper In	10097	1220	Manual Paper Load
22	Printing	10098	142x	Printing
23	Ejecting	10099	143x	Ejecting
24	Warming Up	(10003)	1800	Warming Up
25	Manual Paper Request	411xx	16xx	Manual Paper Request
26	Tray1 Paper Request	412xx	28xx	Tray1 Paper Request
27	Tray2 Paper Request	413xx	29xx	Tray2 Paper Request
28	Feeder Paper Request	414xx	2Axx	Multi-Feeder Paper Request
29	Tray1 Paper Out	412xx	2001	Tray1 Paper Out
30	Tray2 Paper Out	413xx	2002	Tray2 Paper Out
31	Feeder Paper Out	414xx	2004	Multi-Feeder Paper Out
32	Tray2 Cover Open	40076	2112	Tray2 Cover Open
33	PS Not Available	35031	–	
34	Paper Size Error	30034	3000	Paper Size Error
35	Paper Induct Jam	40077	3100	Paper Load Jam
36	Paper Feed Jam	40078	3200	Paper Feed Jam
37	Paper Exit Jam	40079	3300	Paper Exit Jam
38	Page Buffer Overflow	30097	4001	Page Buffer Overflow
39	Macro Buffer Overflow	30098	4002	Macro Buffer Overflow
40	DLL Buffer Overflow	30099	4003	DLL Buffer Overflow
41	Receive Buffer Overflow	30090	4004	Receive Buffer Overflow
42	Print Buffer Overflow	30010	–	
43	Print Overrun Error (Print Underrun Error)	30017	4100-7F 4180-FF	Print Overrun (XXXX) Print Underrun (XXXX)
44	I/D Not Installed	40019	4200	Drum Cartridge Not Installed
45	Cover Open	40021	4F00	Cover Open
46	EEPROM Open	–	–	
47	Controller Error	(40057)	5000	Controller Error 00 (XXXX)
48	Program ROM Check Error	–	6010	Program ROM Check Error (XXXX)

No.	Printer Status	PJL code	OPEL code	Status Message
49	Font ROM Check Error	–	6020	Font ROM Check Error (XXXX)
50	Resident RAM Check Error	–	6030	RAM Check Error (XXXX)
51	EEPROM Check Error	–	6040	EEPROM Check Error (XXXX)
52	Option Software ROM Check Error	–	6050	Option ROM Check Error (XXXX)
53	Option RAM Check Error	–	6060	Option RAM Check Error (XXXX)
54	Fan Motor Error	40083	6070	Fan Motor Error (XXXX)
55	Fuser (Heater) Error	40084	6080	Fuser Error (XXXX)
56	Thermistor Open Error	40085	6091	Thermistor Open Error (XXXX)
57	Thermistor Short Check Error	40086	6092	Thermistor Short Error (XXXX)
58	Toner Sensor Problem	40082	6093	Toner Sensor Error (XXXX)
59	Op-Panel I/F Timeout Error	(40088)	60A0	Operator Panel Error (XXXX)
60	Option I/F Timeout	–	60B0	Option I/F Error
61	Tray2 Timeout Error	(40089)	60B1	Tray2 Timeout Error
62	Feeder Timeout Error	(40090)	60B2	Multi-Feeder Timeout Error (XXXX)
63	Watch Dog Timeout Error	–	60C0	Watch Dog Timeout Error (XXXX)
64	Unsupported CPU	–	–	
65	SSIO Error	40091	–	
66	Monitor Error (Double wait)	(40092)	–	
67	Monitor Error (Argument error)	(40093)	–	
68	Option Timeout Error	40094	–	
69	Option Status Error	40095	–	
70	BG Problem Error	40096	–	
71	System Timer Program Error	40097	–	
72	IPT1 Program Error	40099	–	
73	IPT2 Program Error	40098	–	
74	Printer Undefine code	other than avobe	Other than Avobe	Status Error (XXXX)

3.2 LED Head Marking No.

An item to control the exposure time of LED Head.
The meanings of set values in the LED Head Marking No.
The following table shows set values and their meanings.

LED Head Marking No. Setting Table

No.	Optical Head 300DPI
	Standard
No.1	
No.2	
No.3	
No.4	
No.5	
No.6	505-545
No.7	466-504
No.8	431-465
No.9	398-430
No.10	368-397
No.11	346-367
No.12	314-339
No.13	291-313
No.14	269-290
No.15	248-268
No.16	229-247
No.17	212-228
No.18	196-211
No.19	181-195
No.20	168-180
No.21	155-167
No.22	143-154
No.23	132-142
No.24	122-131
No.25	113-121
No.26	105-112
No.27	097-104
No.28	089-096
No.29	083-088
No.30	077-082
No.31	070-076
No.32	066-069

3.3 Descriptions on Buttons

3.3.1 Printer RAM Check

The Printer RAM Check button is used for the raster buffer and receive buffer, including option RAM, to check free memory space. The progress bar fluctuates in length during the execution of the RAM check.

The following message is showing when the RAM check is finished without problems.

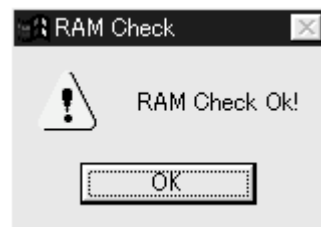

3.3.2 EEPROM Operation

(1) Data Upload Button

The engine menu in a currently-connected printer is read and stored in memory. After the completion of the storage, the EEPROM Download button is enabled. Even when the connected printer is replaced with another printer, data on that read menu is stored. The engine menu is not invoked when a different printer is connected after a Connection Error is occurred once. Porting menu data to another printer is therefore possible.

(2) Data Download Button

By the use of Data Download button after the press of the Data Upload button, printer set values (LED head marking Nos.) and counter values stored using the Data Upload button take effects on the currently-connected printer.

3.3.3 Engine Counter Group

The engine counter group displays and initializes the following counter values. Data to be initialized must be programmed in registry at the time of installation.

- (1) Drum Counter
The number of revolutions of a currently-installed EP drum is indicated.
- (2) Total Drum Counter
The total number of revolutions of EP drums installed after the shipping of the printer is indicated.
- (3) Page Counter
The total number of pages printed on the printer after it is shipped is indicated.
- (4) Reset Button
With the click of the button, set values that have already been programmed in registry (Drum, Total Drum and Page Count values) are established in the printer. The default value is 0/31/0.
Note: When the counter value exceeds the predetermined number of pages, the page counter cannot be reset, causing the Reset button to be disabled.
- (5) Reset All
The message box appears at the click of the button and, for confirmation, the user is asked whether all the values are reset. Then, all set values that have been entered in a file to be initialized (Drum, Total Drum and Page Count values) are programmed in the printer.



Immediately after the counter reset command is sent, the counter read command is sent and, if a response to that command is not reset, the message box for each counter is displayed and an EEPROM write error is posted to the user.

When the printer does not support the reading of counter values, the menu option is dimmed (grayed out), causing the Reset button to be disabled.

To determine whether the printer has the function of reading counter values, the all-counter-value read command must be sent. Any item for which a response has received is decided to be supported.

4. Menu Property Sheet

The following figure provides an example of the Menu Property Sheet display.

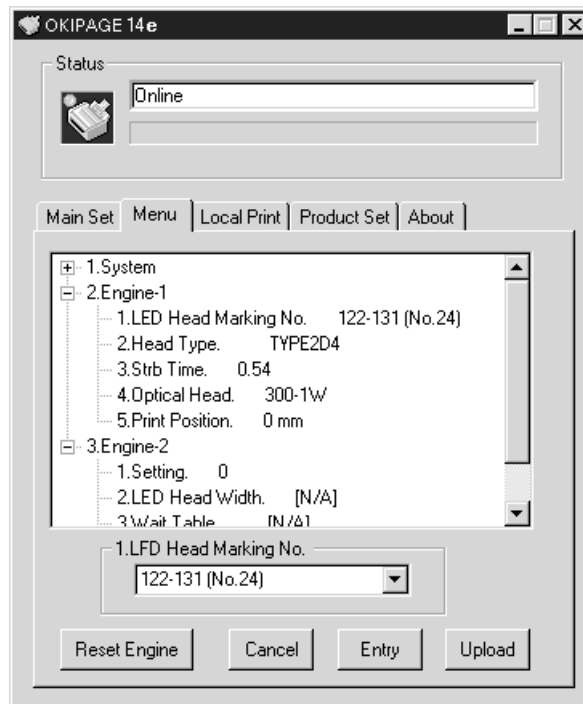

- (1) **Set Item Display Tree View**
Displays setting item names and a list of currently set values. An item with [N/A] in its set value indicates that it is not supported. On that item, there has been no response when a set value read command is sent.
(See the setting items list for setting items.)
Clicking on a setting item opens a set-value-selecting dialog.
- (2) **Configuration Dialog for Selecting Set Value**
Displays this dialog on an item-by-item basis (the LED Head Marking No. combo boxes in the example of the display).
Clicking on a set value makes the selection. The selected value takes effect only when another set value is selected in the “Set Item Display Tree View.” However, the set value is not established in a device.
- (3) **Reset Engine Button**
Sends an engine reset command to a device. After that, all set values are loaded again.
- (4) **Cancel Button**
Disables all changes which have been made after the Property Sheet appears. However, accessing the device side by use of the button is controlling.
- (5) **Entry Button**
Records a currently displayed set value in a device. GUI set values in the engine menu group affect a printer.
Selecting the “Entry” button sends all menu item set commands irrespective of whether change is made to the all menu item GUI display (user-definable) information to be read.
- (6) **Upload Button**
Reads a currently set value established in a device to display the value again.

4.1 Setting Items

(1) Setting Items

The following menu items are displayed on Menu from which settings are changed.

Menu	Item	Words displayed	Setting Item Detail
1.System	1	User	Specifies the destination(s).
	2	Printer Type	Specifies the applicable model(s).
	3	Page PRT	Selects Page Count printing "Enable" or "Disable" in menu printing.
2.Engine-1	1	LED Head Marking No.	Adjusts the exposure time of LED Head.
	2	Head Type	Specifies the correction method of the correction head at 600 DPI.
	3	Strb Time	Specifies the strobe time.
	4	Optical Head	Selects single line (non-correction) type or double line (correction) type for the LED Head data line.
	5	Print Position	Corrects the print start position.
3.Engine-2	1	Setting	Adjusts the transfer current value.
	2	LED Head Width	Specifies the number of physical dots in LED Head.
	3	Wait Table	Selects 150°C or 135°C for wait temperature.
	4	Engine Speed	Specifies the engine speed.

(2) Supported Items Lists by Language

Menu No.	Setting Item	OP14e
		PN254
1-1	Printer Type User	○
1-2	Setting Range	ODA/OEL/INTA/INTL
	Default	ODA
1-3	Page PRT	○
	Setting Range	DISABLE/ENABLE
	Default	DISABLE
2-1	LED Head Marking No.	○
	Setting Range	600DPI: 155- ~ -020 (No. 1 to No. 32) 300DPI: 505-545 ~ 066-069 (No. 1 to No. 32) (Note 1)
	Default	No.17
2-2	Head Type	×
	Setting Range	TYPE1/TYPE2D2/TYPE2D4
	Default	TYPE2D4
2-3	Strb Time	×
	Setting Range	0.54, 0.50, 0.46, 0.42
	Default	0.50
2-4	Optical Head	○
	Setting Range	300-1W(non-correction)/300-2W(correction)/600-4W
	Default	300-1W
2-5	Print Position	○
	Setting Range	-4.00mm ~ +3.5mm
	Default	0.00mm
3-1	Setting	○
	Setting Range	+2 ~ -2
	Default	0
3-2	LED Head Width	×
	Setting Range	Full (2560 dots) /Narrow (2496 dots)
	Default	
3-3	Wait Table	×
	Setting Range	Normal/Low Level
	Default	
3-4	English Speed	×
	Setting Range	6ppm/8ppm
	Default	

- Note:** 1. The meanings of set values in the LED Head Marking No. differ according to which Optical Head is selected.
The following table shows set values and their meanings.

LED Head Marking No. Setting Table

No.	Optical Head 600DPI	Optical Head 300DPI
	Standard	Standard
No.1	155-	
No.2	145-154	
No.3	136-144	
No.4	127-135	
No.5	119-126	
No.6	111-118	505-545
No.7	104-110	466-504
No.8	097-103	431-465
No.9	091-096	398-430
No.10	085-090	368-397
No.11	080-084	346-367
No.12	074-079	314-339
No.13	070-073	291-313
No.14	065-069	269-290
No.15	061-064	248-268
No.16	058-060	229-247
No.17	053-057	212-228
No.18	050-052	196-211
No.19	047-049	181-195
No.20	044-046	168-180
No.21	041-043	155-167
No.22	038-040	143-154
No.23	036-037	132-142
No.24	033-035	122-131
No.25	031-032	113-121
No.26	029-030	105-112
No.27	027-028	097-104
No.28	026-	089-096
No.29	025-	083-088
No.30	022-024	077-082
No.31	021-	070-076
No.32	-020	066-069

5. Local Print Property Sheet

The following figure provides an example of the Local Print Property Sheet.

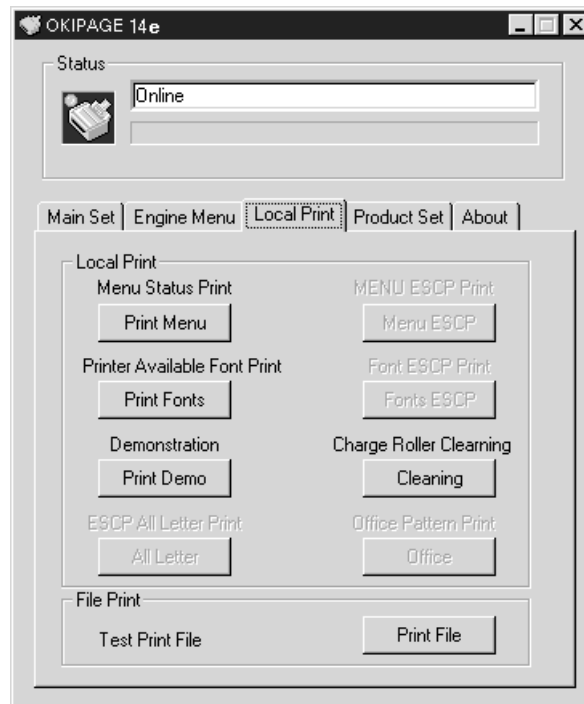

(1) Local Print

Sends a local print command at the click of the button. Applicable models are as follows:

No.	Item	Applicable Model
1	Menu Status Print	○
2	Demonstration	○
3	Printer Available Font Print	○
4	Charge Roller Cleaning Print	○
5	ESCP Menu Status Print	
6	Printer Available ESCP Font Print	
7	ESCP Japanese All letter size Print	
8	Japanese Office Pattern Print	

(2) Test File Print

Opens a dialog box (Windows API) for file selection and waits for a printing file to be entered by an operator.

The selected file is sent as-is.

A language-specific extension is supplied with each file.

- PRN for PjL Language
- HBP for OPEL Language

Here is an example of the file-selecting dialog box display.

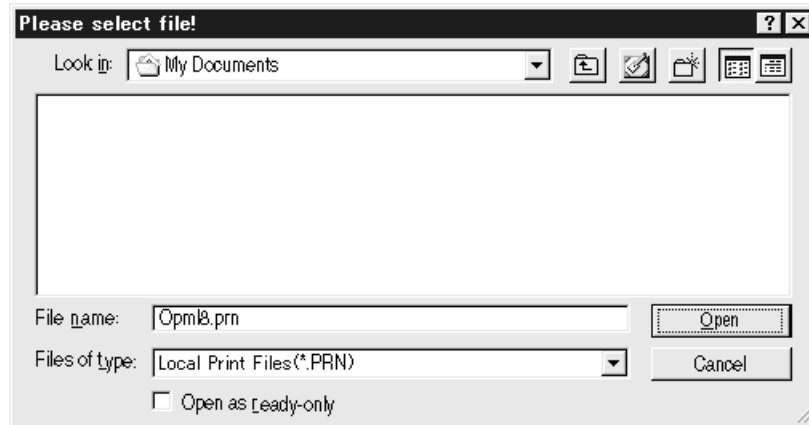

6. Product Set Property Sheet

The following shows an example of the product set property sheet display. The sheet is only displayed and data on it cannot be changed in the field.

The screenshot shows a software window titled "MICROLINE 14e". At the top left, there is a "Status" section with a printer icon and a text field containing "Online". Below this is a menu bar with "Main Set", "Menu", "Local Print", "Product Set" (which is highlighted), and "About". The main content area is divided into two sections: "Device ID" and "USB ID". The "Device ID" section contains several fields: "Manufacture" (OKI DATA CORP), "Command Set" (P, J, L, P, C, L, X, L, P, C, L, E, P, S, O, N, F, X, I, B, M, P, P, R), "Model Name" (MICRO LINE 14e), "Class" (PRINTER), "Description" (MICRO LINE 14e), and "Compatible ID" ([none]). The "USB ID" section contains two fields: "Descriptor" (06BC 0000 0000 00 00 00) and "Serial No." (000000000000). At the bottom of the window, there are three buttons: "Upload", "Download", and "Default".

- (1) Device ID
The device ID of a printer is displayed.
- (2) USB ID
The ID of an USB is set.
- (3) Upload Button
The device ID and USB ID currently-programmed in the printer are uploaded and displayed.
- (4) Download Button
The displayed device ID and USB ID are downloaded after they are changed.
- (5) Default Button
The default Product Set command is sent. The settings in Product Set is changed to the destination defaults that are shown to the user.

7. About Property Sheet

About Property Sheet shows maintenance utility and printer firmware information.

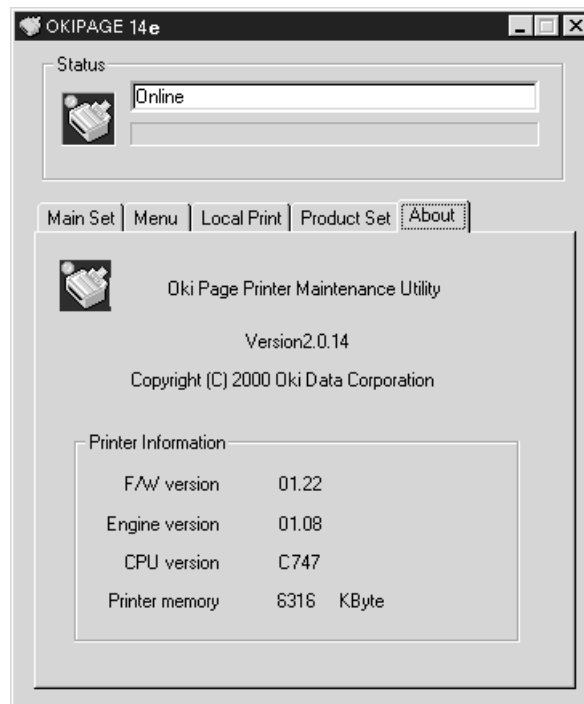

(1) About

Display	Description
Oki Page Printer Engine Maintenance	Version Number of This Application

(2) Printer Information

Display	Description
F/W version	Version Number of Connected Printer F/W
Engine version	Version Number of Connected Printer engine F/W
CPU version	Information on CPU Equipped with Connected Printer
Printer memory	Free Memory Size of Connected Printer

8. For Invalid Events

8.1 Failed Printer Setting

When printer setting has failed (EEPROM write error), the error message is displayed: "Save Data Error! xxxxxxxx" (The message "xxxxxxx" vary by error section.)

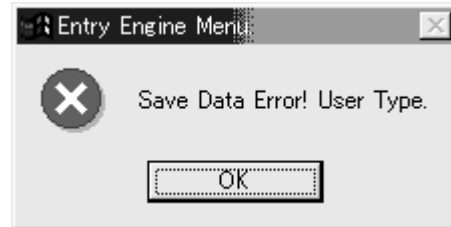

8.2 RAM Check Error

When an error is detected during RAM checking, the error message appears.

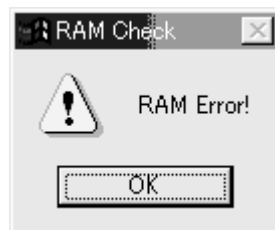

Appendix E MULTI-PURPOSE FEEDER

1. OUTLINE

1.1 Functions

This Multi-Purpose Feeder is installed on the front section of the printer, and it supplies paper automatically through the operation of pulse motor, which is driven by signals sent from the printer. The main functions are the followings:

- Paper that can be used:

[Paper Types]

- Standard paper: Xerox 4200 (20-lb)
- Special paper: OHP sheets (for PPC), label sheets (PPC sheets)
* Not guaranteed for OHP sheets with attachments on the edge or reverse side.
- Cut sheet size: Letter, Executive, A4, A5, B5, A6
Special size: Width: 87 to 216mm
Length: 148 to 297mm

[Weight and Thickness]

- 16-lb to 32-lb (60~128 g/m²)
- For labels and OHP Sheets: Label sheets: 0.1 to 0.15mm
OHP sheets: 0.08 to 0.11mm

* When using sheets which exceed 24-lb, make sure that the paper exits through the face-up route.

1.2 External View and Component Names

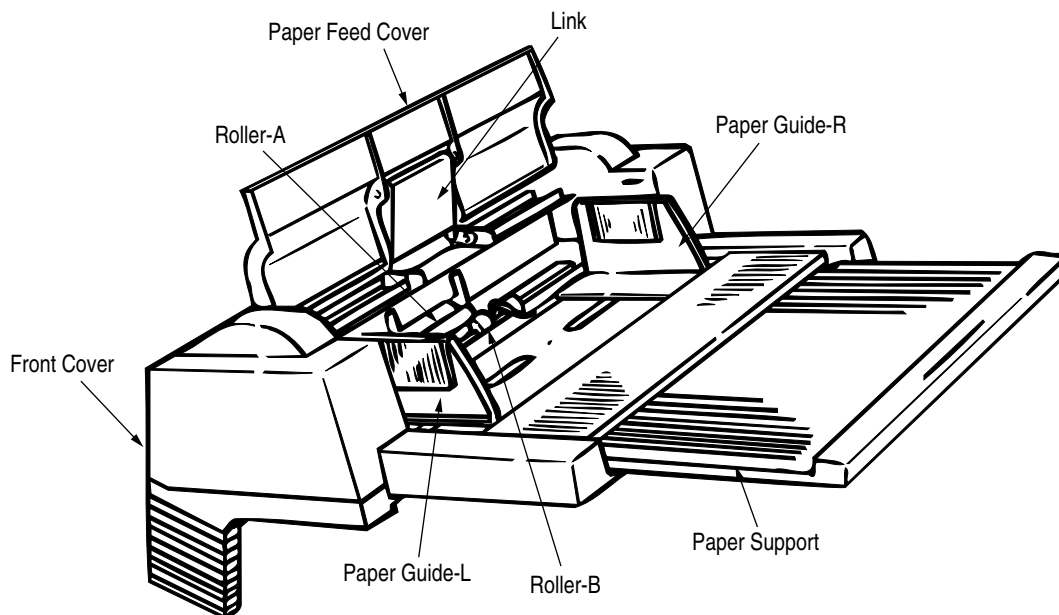

Figure 1-1

2. MECHANISM DESCRIPTION

2.1 General Mechanism

The Multi-Purpose Feeder feeds the envelopes and paper into the printer by receiving the signal from the printer, which drives the pulse motor inside the Multi-Purpose Feeder, and this motion is transmitted to rotate roller-A and B. The envelope or paper is delivered from the separator into the printer.

Once delivered into the printer, the envelope or paper is then controlled and fed through by pulse motor (registration) of the printer.

2.2 Hopper Mechanism

The hopper automatically feeds the printer with the envelope or paper being set, one sheet at a time. After the envelope or paper is set in the Multi-Purpose Feeder, the pulse motor moves the envelope or paper and a single envelope or paper caught by the separator is fed into the printer.

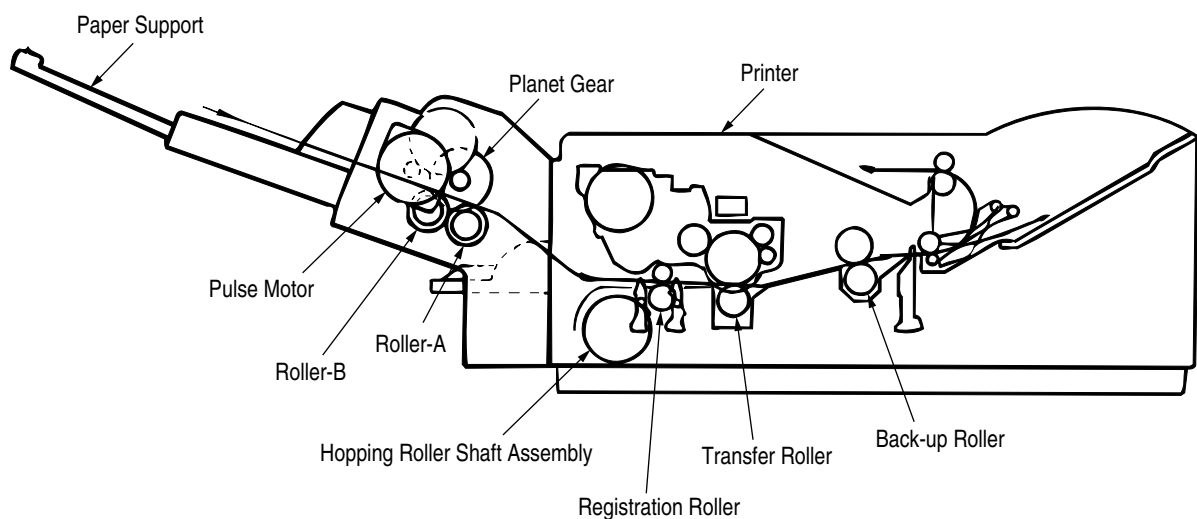

3. PARTS REPLACEMENT

This section covers the procedures for the disassembly, reassembly and installations in the field. This section describes the disassembly procedures, and for reassembly procedures, basically proceed with the disassembly procedures in the reverse order.







3.1 Precautions Concerning Parts Replacement

- (1) Parts replacements must be carried out, by first turning the printer power switch off "O" and removing the Multi-Purpose Feeder from the printer.
- (2) Do not disassemble the Multi-Purpose Feeder if it is operating normally.
- (3) Establish the extent of disassembly suitable for the purpose of the procedure, and do not disassemble any more than necessary.
- (4) Only specified service tools may be used.
- (5) Disassembly must be carried out according to the prescribed procedures. Parts may be damaged if such procedures are not followed.
- (6) Small parts such as screws and collars can easily be lost, therefore these parts should be temporarily fixed in the original location.
- (7) When handling printed circuit boards, do not use any glove which may generate static electricity.
- (8) Do not place the printed circuit boards directly on the equipment or floor.

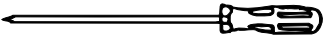
[Service Tools]

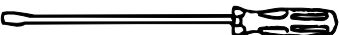
Table 3-1 shows the tools required for the replacement of printed circuit boards, assemblies and units in the field.

Table 3-1 Service Tools

No.	Service Tools	Q'ty	Application	Remarks	
1		No. 1-100 Philips screwdriver	1	2 ~ 2.5 mm screws	
2		No. 2-100 Philips screwdriver	1	3 ~ 5 mm screws	
3		No. 3-100 screwdriver	1		
4		No. 5-200 screwdriver	1		
5		Digital multimeter	1		
6		Pliers	1		
7		Handy cleaner	1		

3.2 Parts Layout

This section describes the layout of the main components.

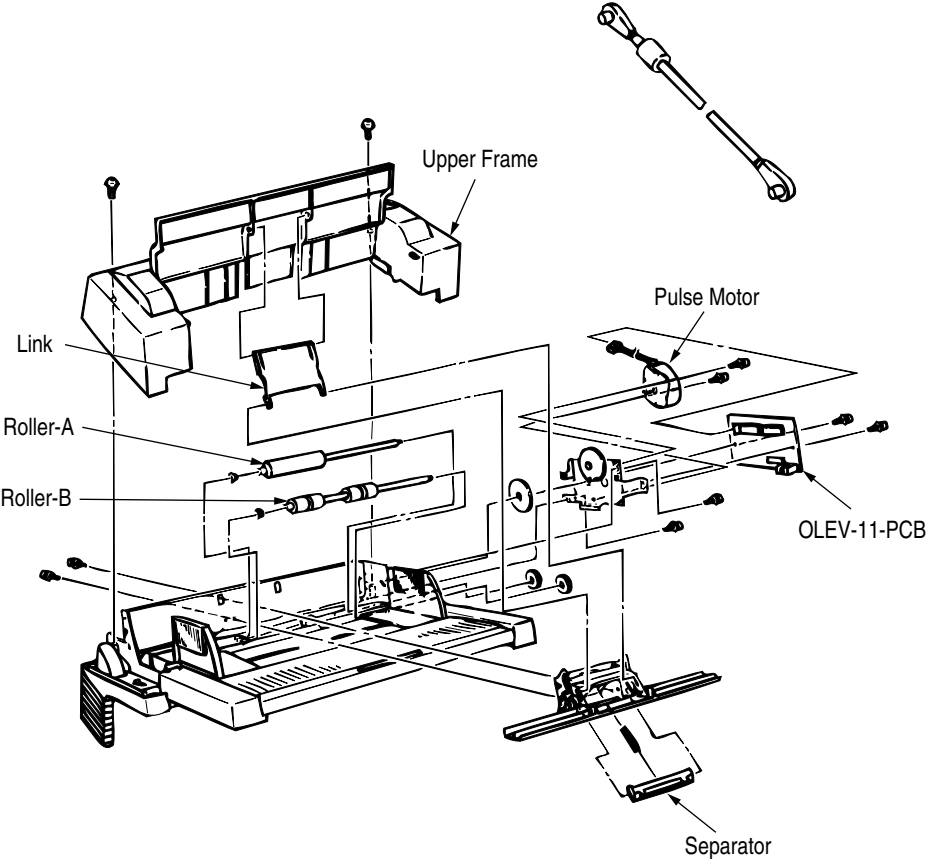
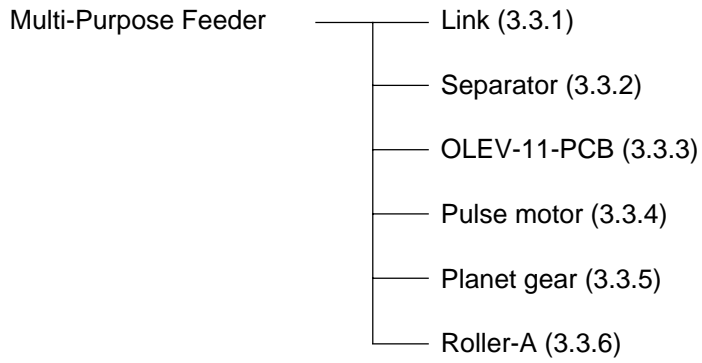

Figure 3-1

3.3 Parts Replacement Methods

This section describes the parts replacement methods for the components listed in the disassembly order diagram below.



3.3.1 Link

- (1) Open paper feed cover ①, and disengage the paper feed cover ① and link ③, while lifting the paper hold ②.
- (2) Remove the paper hold ② off the arm ④.
- (3) Disengage the link ③ from the arm ④, and remove it.

* Be careful not to deform the link and arm.

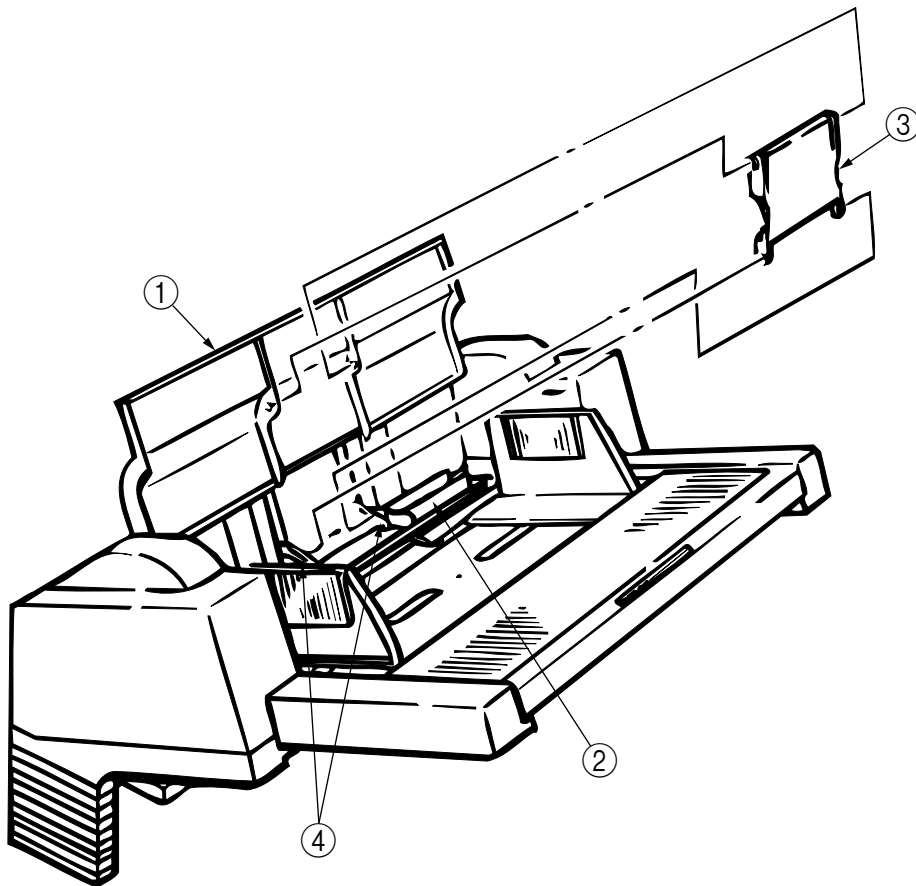

3.3.2 Separator

- (1) Turn the power switch off "O" and remove the connector cable.
- (2) Disengage the link and paper feeder cover (see 3.3.1).
- (3) Remove 2 screws ①, disengage the locks at 2 locations on the upper frame ② with a screwdriver, and remove the upper frame ②.
- (4) Remove 2 screws ③, and take out the separator assembly ④.
- (5) Disengage the separator ⑦ from the separator bracket ⑥ while lifting the paper hold ⑤, and take out the separator (be careful not to lose the spring ⑧ when you are doing this).

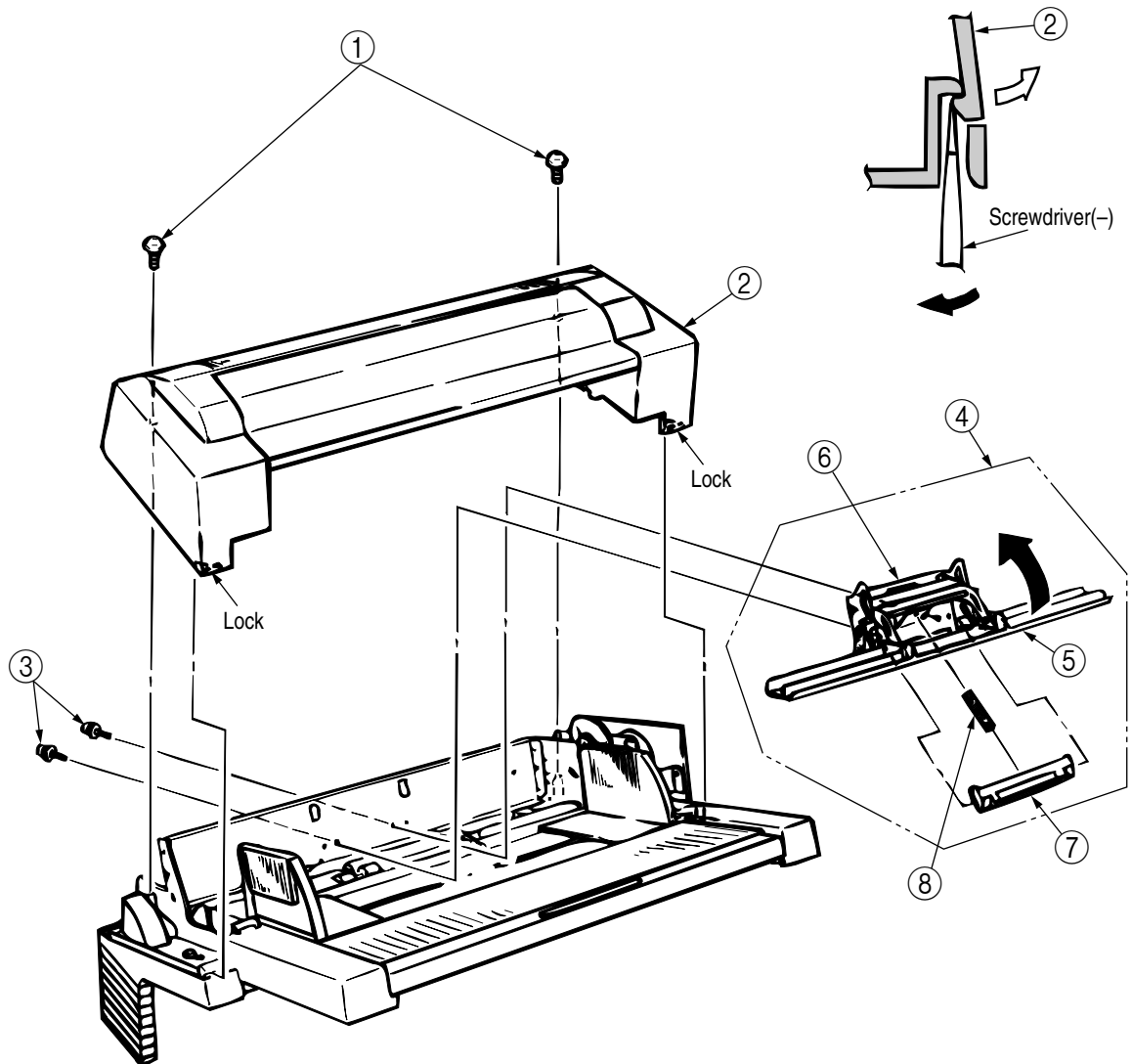

3.3.3 OLEV-11-PCB

- (1) Remove the upper frame [see 3.3.2 steps (1) through (3)].
- (2) Remove the connector ①.
- (3) Remove 2 screws ②, and remove the OLEV-11 PCB ③.

When reinstalling the printed circuit board, be careful to make sure that the sensor plate is being set correctly.

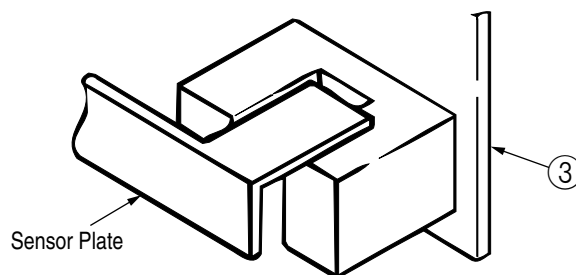
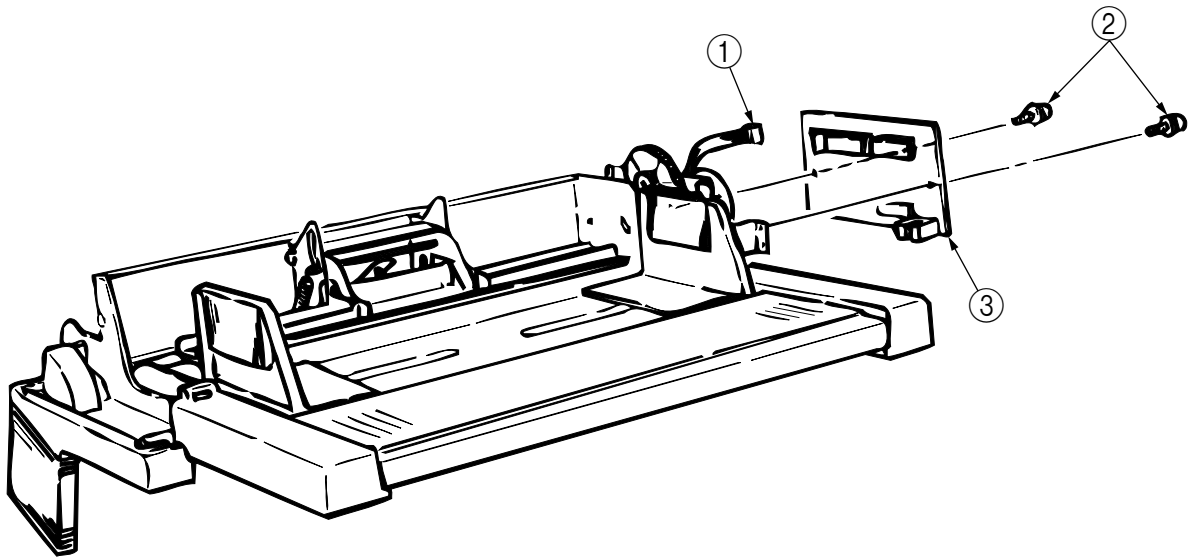

3.3.4 Pulse Motor

- (1) Remove the upper frame [see 3.3.2 steps (1) through (3)].
- (2) Remove the OLEV-11-PCB (see 3.3.3).
- (3) Remove 2 screws ①, and remove the pulse motor ②.

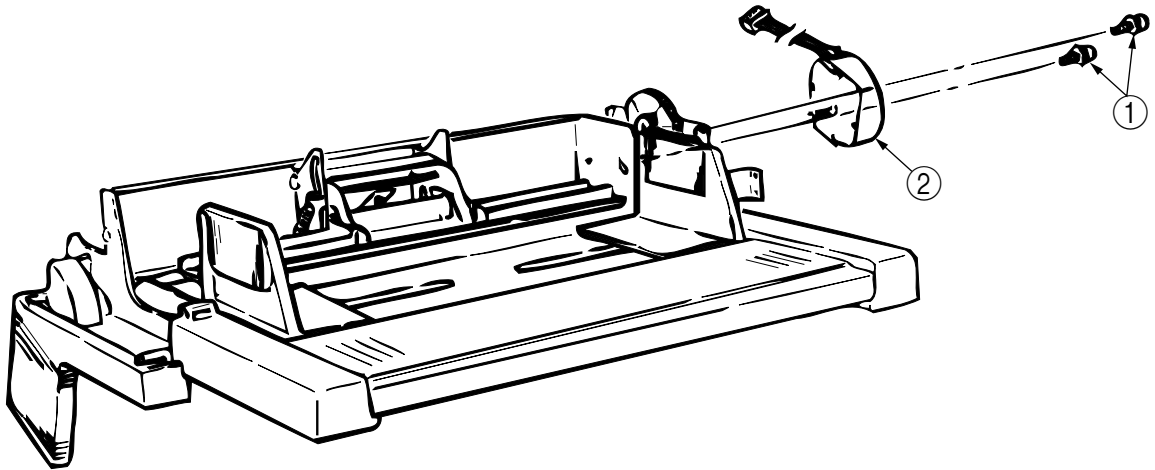

3.3.5 Planet Gear

- (1) Remove the upper frame [see 3.3.2 steps (1) through (3)].
- (2) Remove the OLEV-11-PCB (see 3.3.3).
- (3) Remove 2 screws ①, and remove the motor bracket assembly ② and planet gear ③.

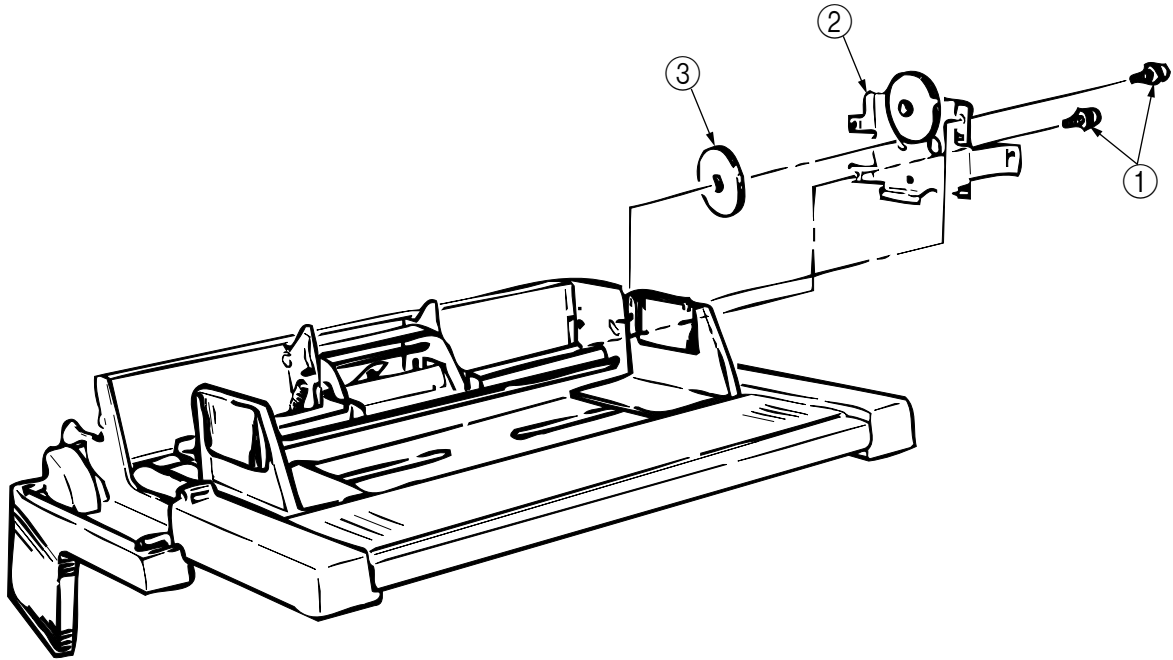

3.3.6 Roller-A and B

While only the removal procedure for roller-A is described here, the removal procedure for roller-B is basically same. When removing roller-B, however, be careful not to deform the sensor plate.

- (1) Remove the upper frame [see 3.3.2 steps (1) through (3)].
- (2) Remove the separator assembly (see 3.3.2).
- (3) Remove the OLEV-11-PCB (see 3.3.3).
- (4) Remove the motor bracket (see 3.3.5).
- (5) Remove the gear ①.
- (6) Shift the roller-A ② to the right, lift it on its left side and slide it out (the bearing ③ also comes off while you are doing this, so be careful not to lose it).

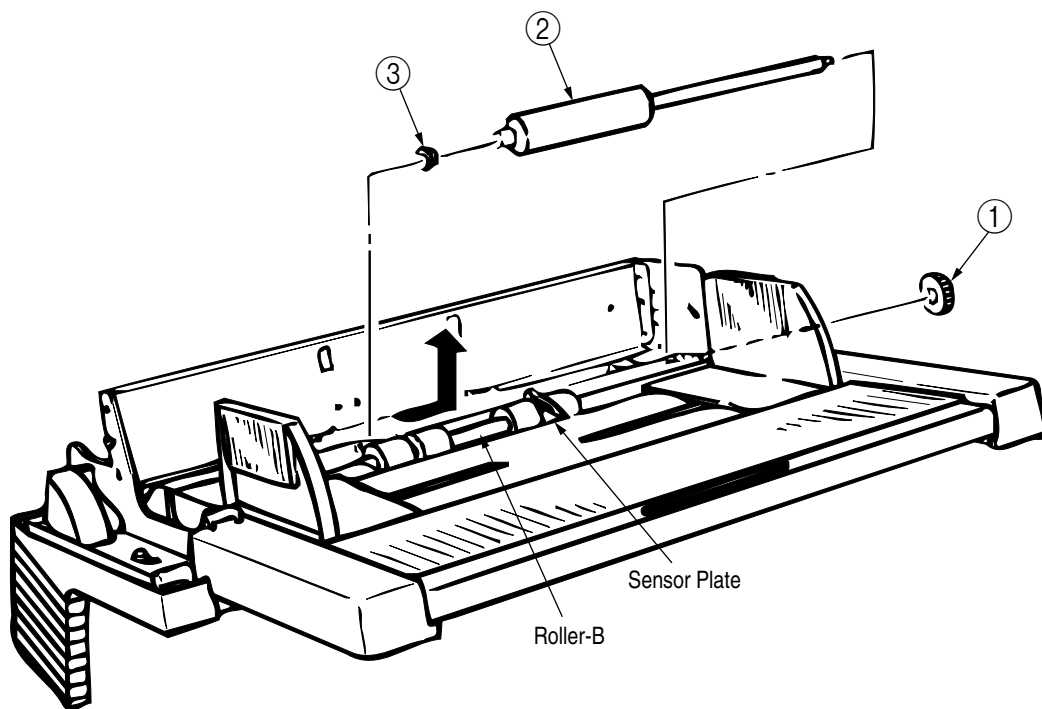

4. TROUBLESHOOTING

4.1 Precautions Prior to the Troubleshooting

- (1) Go through the basic checking items provided in the Printer Handbook.
- (2) Obtain detailed information concerning the problem from the user.
- (3) Go through checking in the conditions similar to that in which the problem occurred.

4.2 Preparations for the Troubleshooting

- (1) Display on the operator panel
The status of the problem is displayed on the LED on the operator panel.

[ODA /OEL/INT]

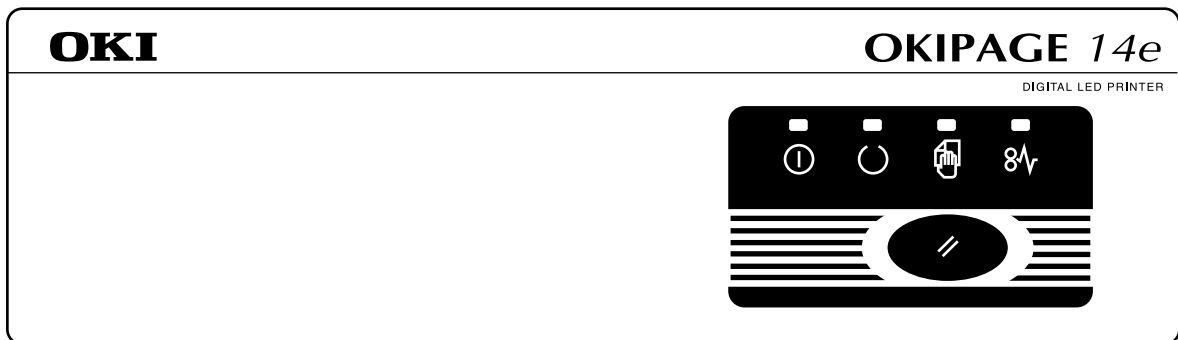

4.3 Troubleshooting Method

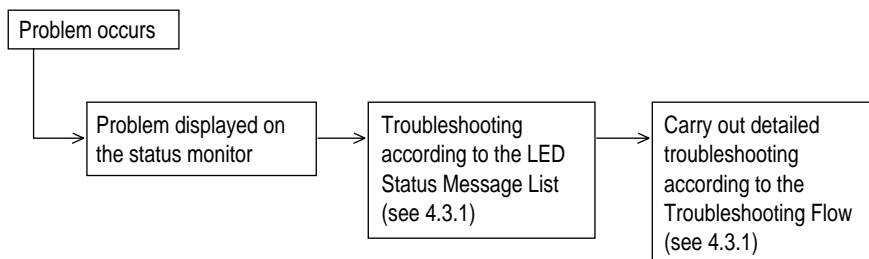

When a problem occurs, go through the troubleshooting according to the following procedure.



4.3.1 LED Status Message List

The listing of the statuses and problems displayed in the form of messages on the status monitor is provided in Table 4-1.

Table 4-1

Classification	LED Status Message	Description	Recovery method
Jam error	 Blinking OFF OFF	Notifies of occurrence of jam while the paper is being fed from Multi-Purpose Feeder.	<ul style="list-style-type: none"> Check the paper in the Multi-Purpose Feeder. Carry out the recovery printing by opening and closing the cover, and turn the error display off. <ul style="list-style-type: none"> When the problem occurs frequently, go through the Troubleshooting.
Paper size error	 Blinking OFF OFF	Notifies of incorrect size paper feeding from Multi-Purpose Feeder.	<ul style="list-style-type: none"> Check the paper in the Multi-Purpose Feeder. Also check to see if there was a feeding of multiple sheets. Carry out the recovery printing by opening and closing the cover, and turn the error display off.
Tray paper out	 Blinking OFF OFF	Notifies of no paper state of the Multi-Purpose Feeder.	<ul style="list-style-type: none"> Load the paper in Multi-Purpose Feeder.

- (JAM error)

Paper Inlet Jam

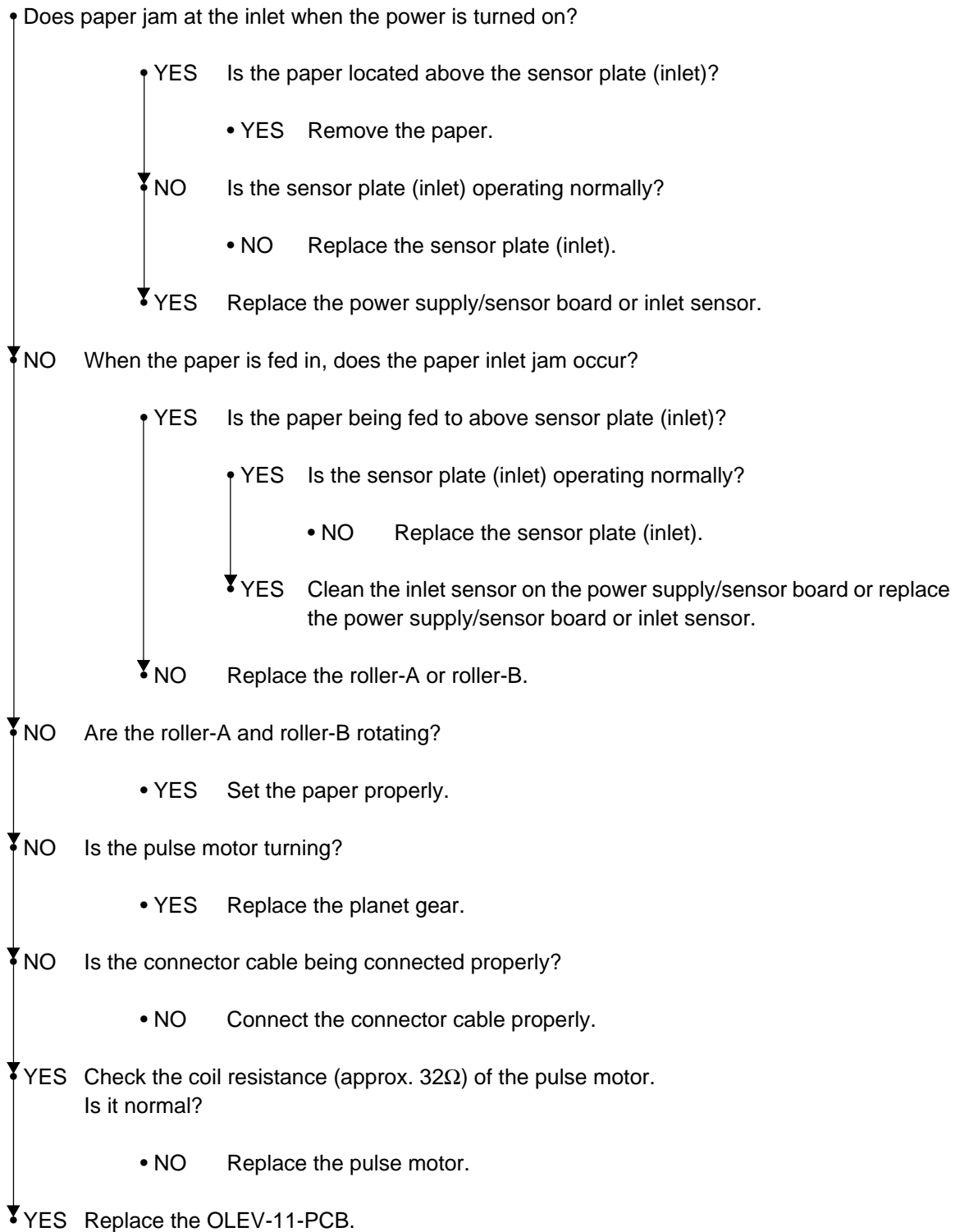

5. CONNECTION DIAGRAM

5.1 Interconnection Diagram

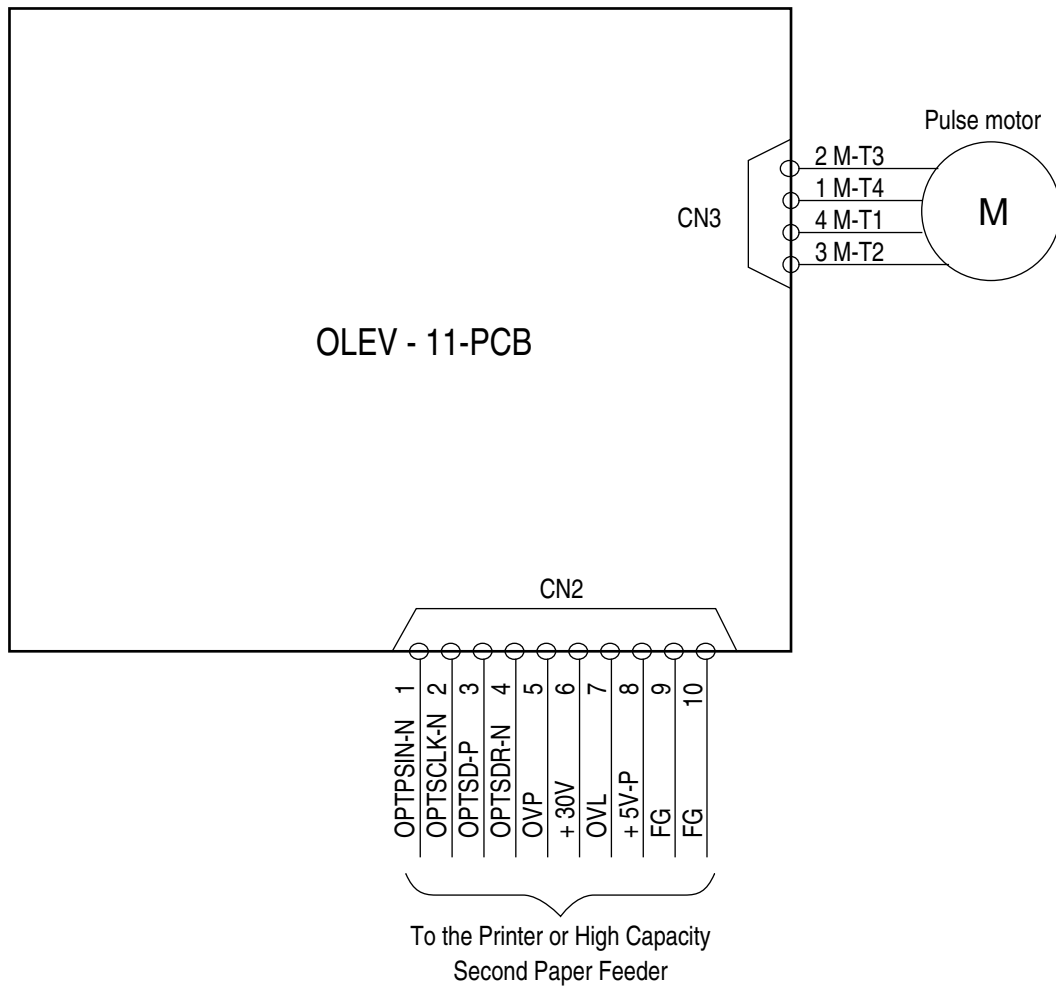

5.2 PCB Layout

OLEV-11-PCB

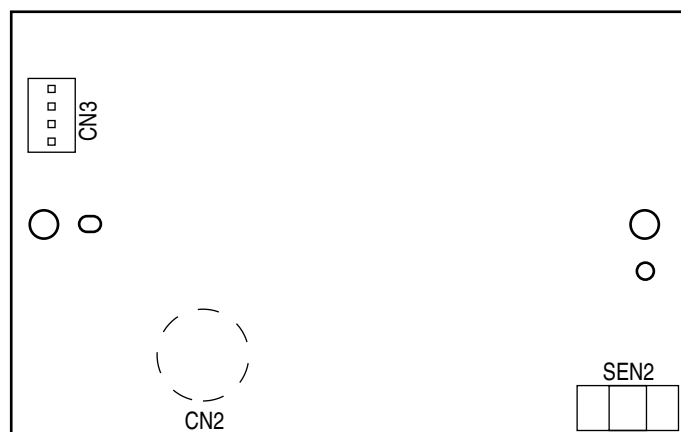

6. PARTS LIST

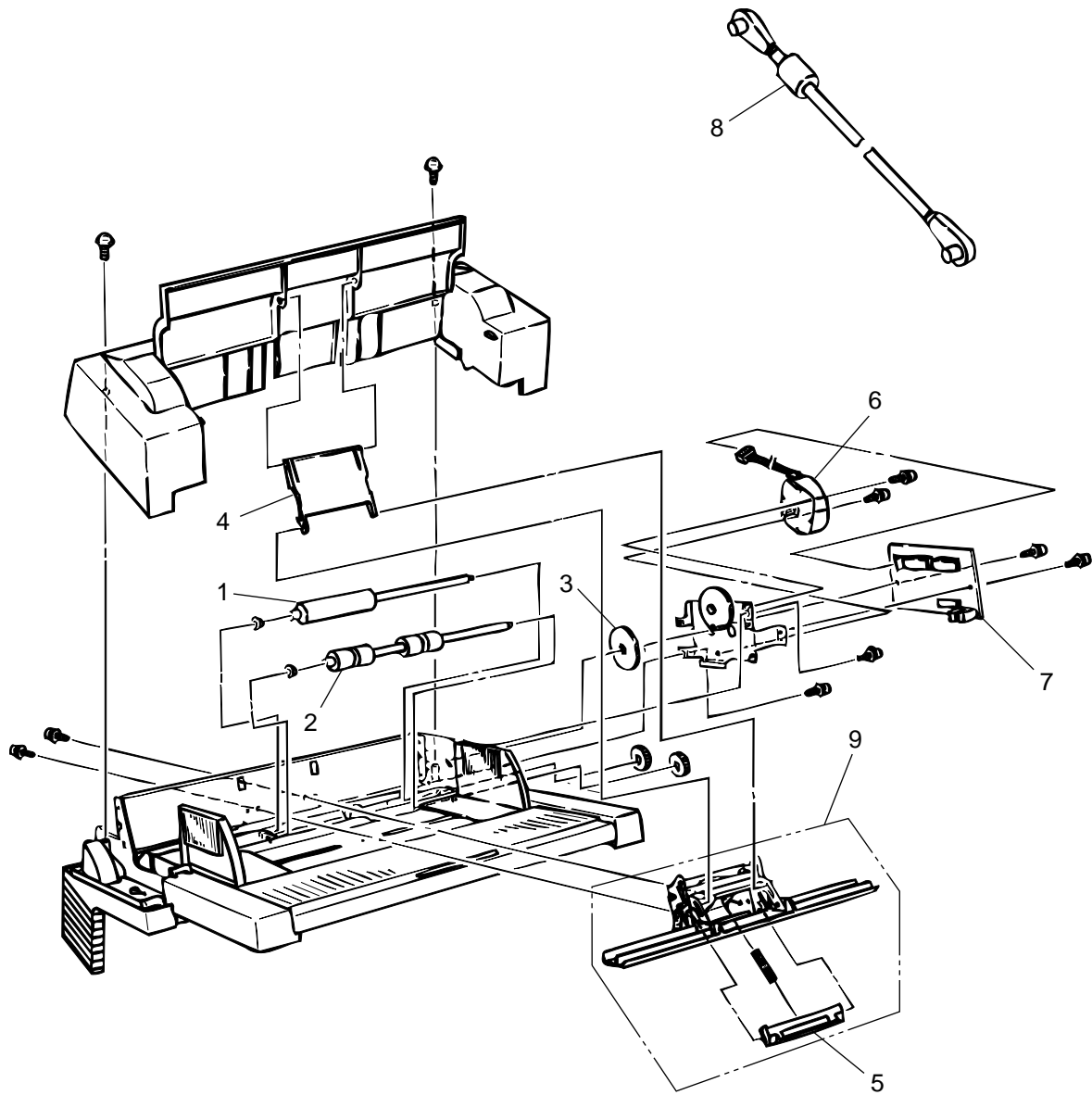

Figure 6-1 Multi-Purpose Feeder

Table 6-1 Multi-Purpose Feeder

No.	Description	OKI-J Part No.	ODA Part No.	Q'ty	Remark
1	Roller-A	3PB4083-5514P001		1	
2	Roller-B	3PB4083-5524P001		1	
3	Planet gear	4PP4083-5520P001		1	
4	Link	3PP4083-5540P001		1	
5	Separator	4PP4083-5544G001		1	
6	Pulse motor	4PB4083-6075P001		1	Same as printer unit.
7	OLEV-11-PCB	4YA4121-1014G011		1	
8	Connector cable	3YS4011-3141P003		1	For ODA
		3YS4011-3141P001		1	For OEL/INT
9	Separator assy	3PA4083-5549G001		1	

Appendix F HIGH CAPACITY SECOND PAPER FEEDER MAINTENANCE MANUAL

1. OUTLINE

1.1 Functions

The printer is mounted on top of this High Capacity Second Paper Feeder. The High Capacity Second Paper Feeder supplies paper automatically through the operation of pulse motor (hopping), which is driven by signals sent from the printer.

The main functions are the followings:

- Paper that can be used:

[Paper Type]

- Standard paper: Xerox 4200 (20-lb)
- Special paper: OHP sheets (for PPC), Label sheets (PPC sheets); use of envelopes or thick paper is not possible.
- Cut sheet size: A4, A5, B5, Letter, Executive, Legal13, Legal14
- Special size: Paper width: 148 to 216mm
Paper length: 210 to 355.6mm

[Weight]

- 16-lb to 24-lb (60 to 90 g/m²)
- Paper setting quantity: 500 sheets of paper weighing 64 g/m²

1.2 External View and Component Names

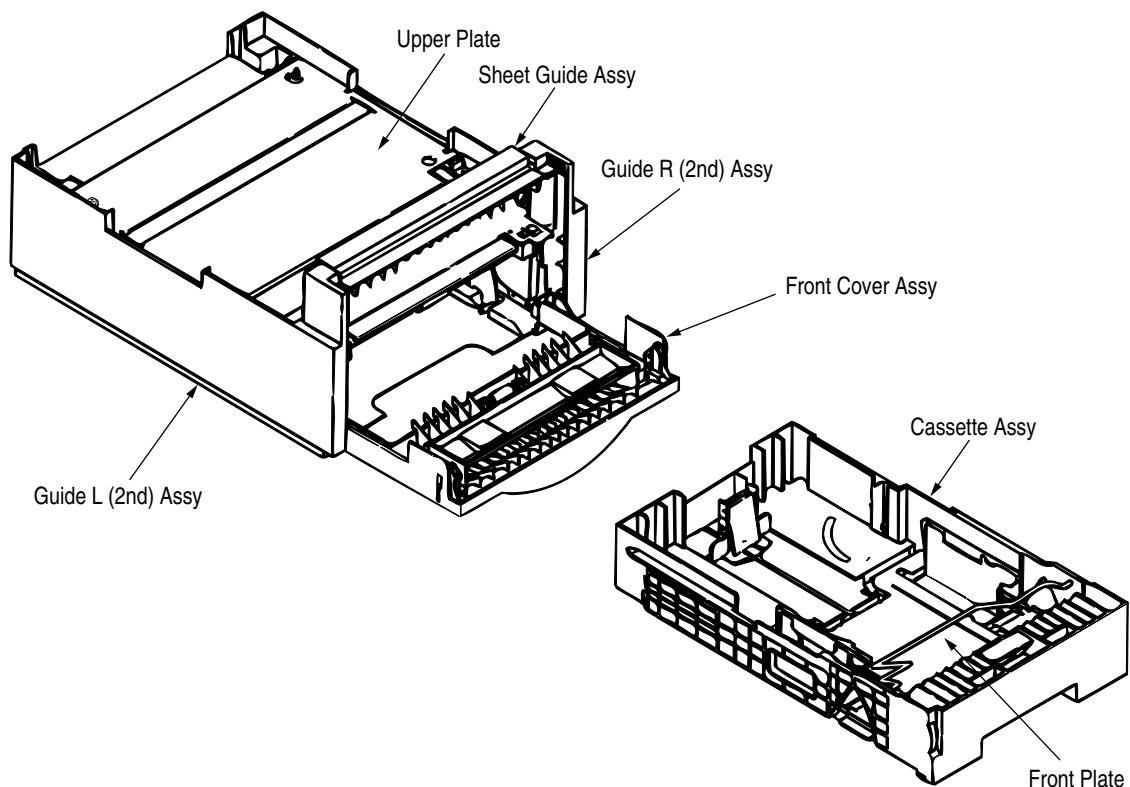

Figure 1-1 External View and Component Names

2. MECHANISM DESCRIPTION

2.1 General Mechanism

The High Capacity Second Paper Feeder feeds the paper into the printer by receiving the signal from the printer, which drives the pulse motor inside the High Capacity Second Paper Feeder, and this motion is transmitted to rotate the one-way clutch of the hopping frame assembly. The paper is delivered from the hopper into the printer through the turning of the hopping roller and feed roller.

Once delivered into the printer, the paper is then controlled and fed through by pulse motor (registration) of the printer.

2.2 Hopper Mechanism

The hopper automatically feeds the printer with the paper being set, single sheet at a time. When the paper is loaded in the paper cassette, it is then transported by the pulse motor, carrying forward only a single sheet caught by the brake shoe at a time.

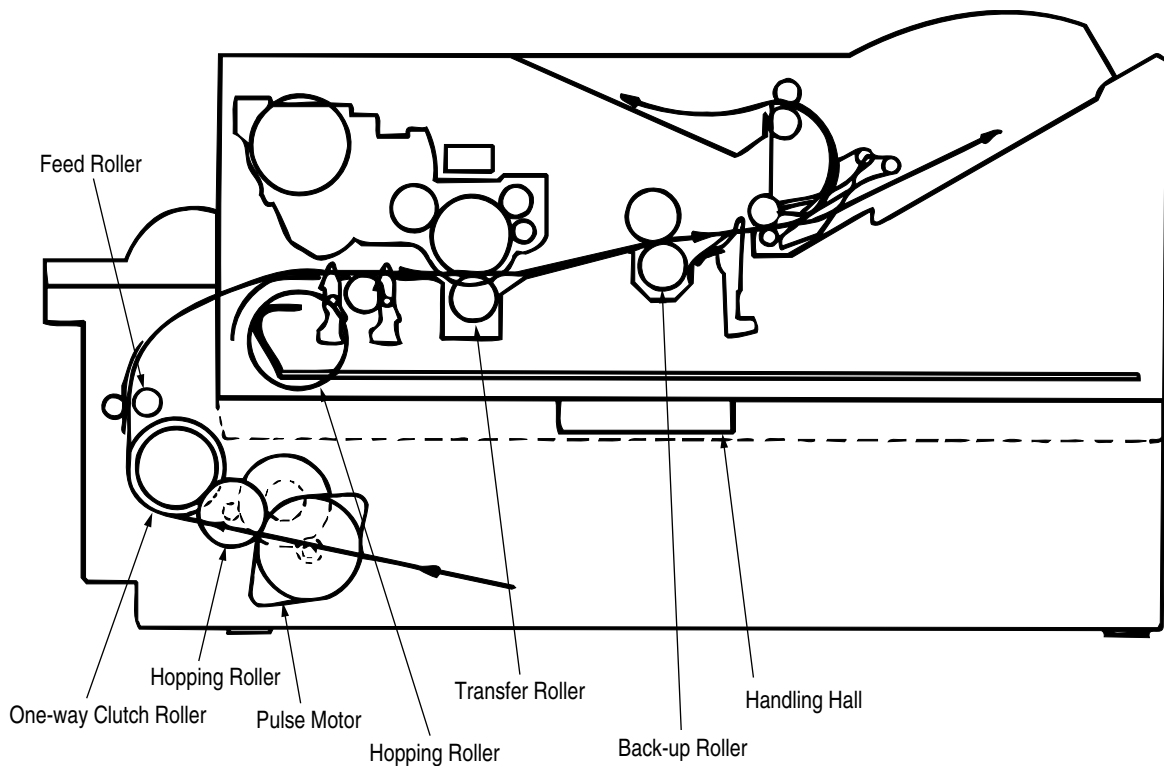

3. PARTS REPLACEMENT

This section covers the procedures for the disassembly, reassembly and installations in the field. This section describes the disassembly procedures, and for reassembly procedures, basically proceed with the disassembly procedures in the reverse order.





3.1 Precautions Concerning Parts Replacement

- (1) Parts replacements must be carried out, by first turning the printer power switch off "O" and removing the printer from the High Capacity Second Paper Feeder.
- (2) Do not disassemble the High Capacity Paper Feeder if it is operating normally.
- (3) Establish the extent of disassembly suitable for the purpose of the procedure, and do not disassemble any more than necessary.
- (4) Only specified service tools may be used.
- (5) Disassembly must be carried out according to the prescribed procedures. Parts may be damaged if such procedures are not followed.
- (6) Small parts such as screws and collars can easily be lost, therefore these parts should be temporarily fixed in the original location.
- (7) When handling printed circuit boards, do not use any glove which may generate static electricity.
- (8) Do not place the printed circuit boards directly on the equipment or floor.

[Service Tools]

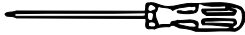
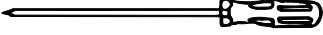
Table 3-1 shows the tools required for the replacement of printed circuit boards, assemblies and units in the field.

Table 3-1 Service Tools

No.	Service Tools	Q'ty	Application	Remarks
1	 No. 1-100 Philips screwdriver	1	2 ~ 2.5 mm screws	
2	 No. 2-100 Philips screwdriver	1	3 ~ 5 mm screws	
3	 No. 3-100 screwdriver	1		
4	 Digital multimeter	1		
5	 Pliers	1		

3.2 Parts Layout

This section describes the layout of the main components.

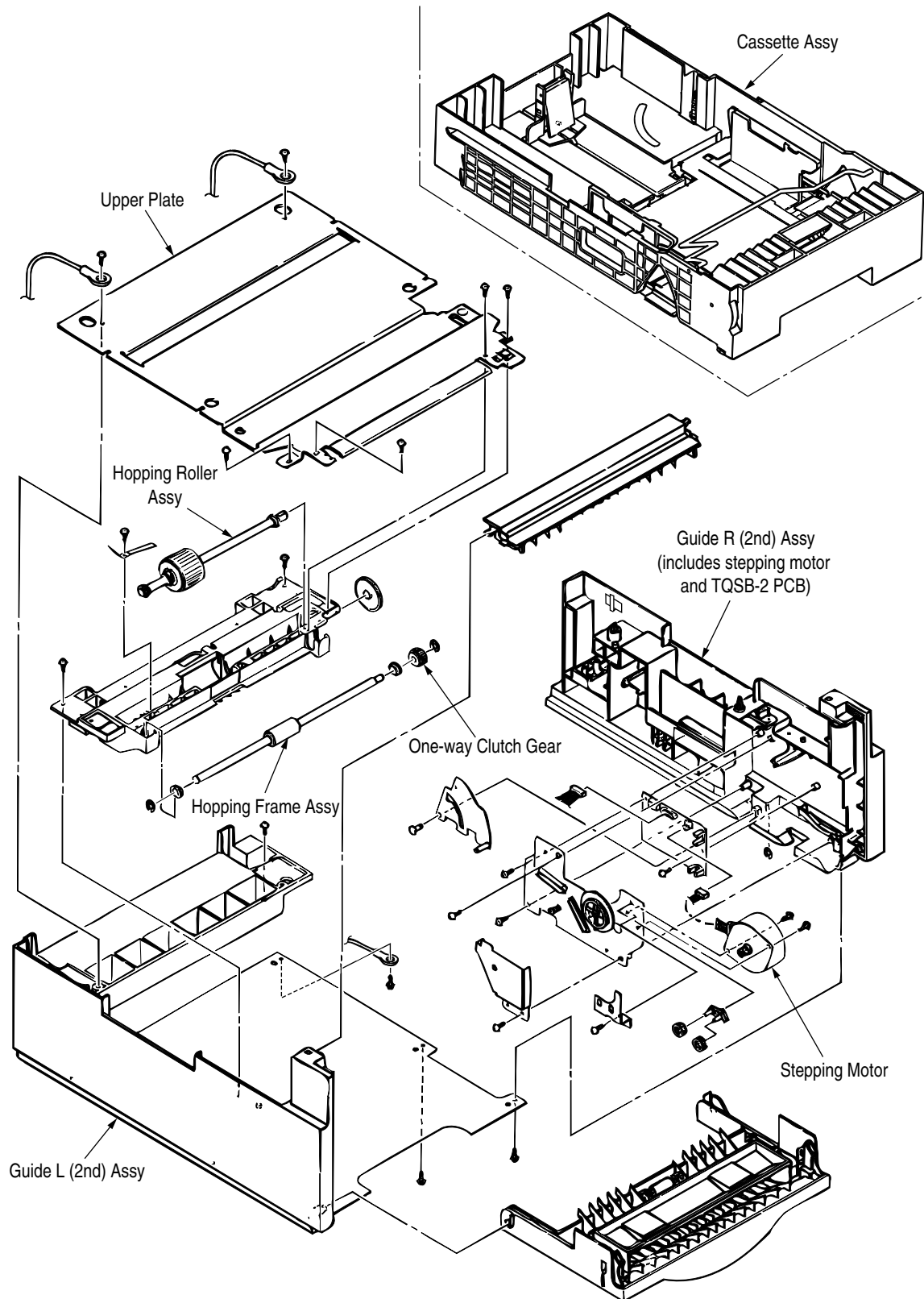
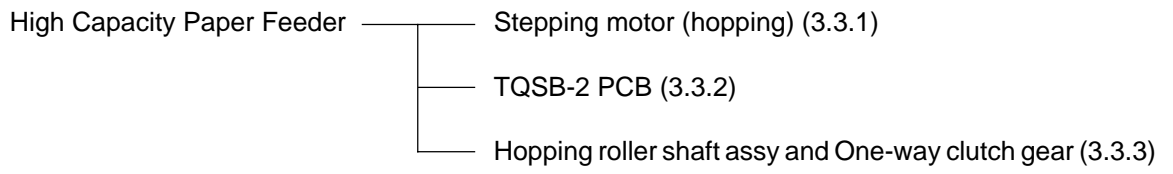

Figure 3-1

3.3 Parts Replacement Methods

This section describes the parts replacement methods for the components listed in the disassembly order diagram below.



3.3.1 Stepping Motor (Hopping)

- (1) Turn the printer power switch off, pull out the AC cord from the outlet. Remove the printer off High Capacity Second Paper Feeder.
- (2) Take the paper cassette assy ❶ out of High Capacity Second Paper Feeder.
- (3) Remove six screws ❷ and remove the upper plate ❸. Remove two screws ❺ and remove the hopping frame assy ❻.
- (4) Remove the front cover assy ❹ off the guide boss on the guide L (2nd) assy ❼ by bending the guide L (2nd) assy ❼ in the direction of arrow shown in the magnified view below.
- (5) Pull the sheet guide assy ❸ in the direction of arrow ❶ and also push in the direction of arrow ❷ to unlock the notch, and bring the sheet guide assy ❸ in the direction of arrow ❸ to remove the sheet guide assy ❸.

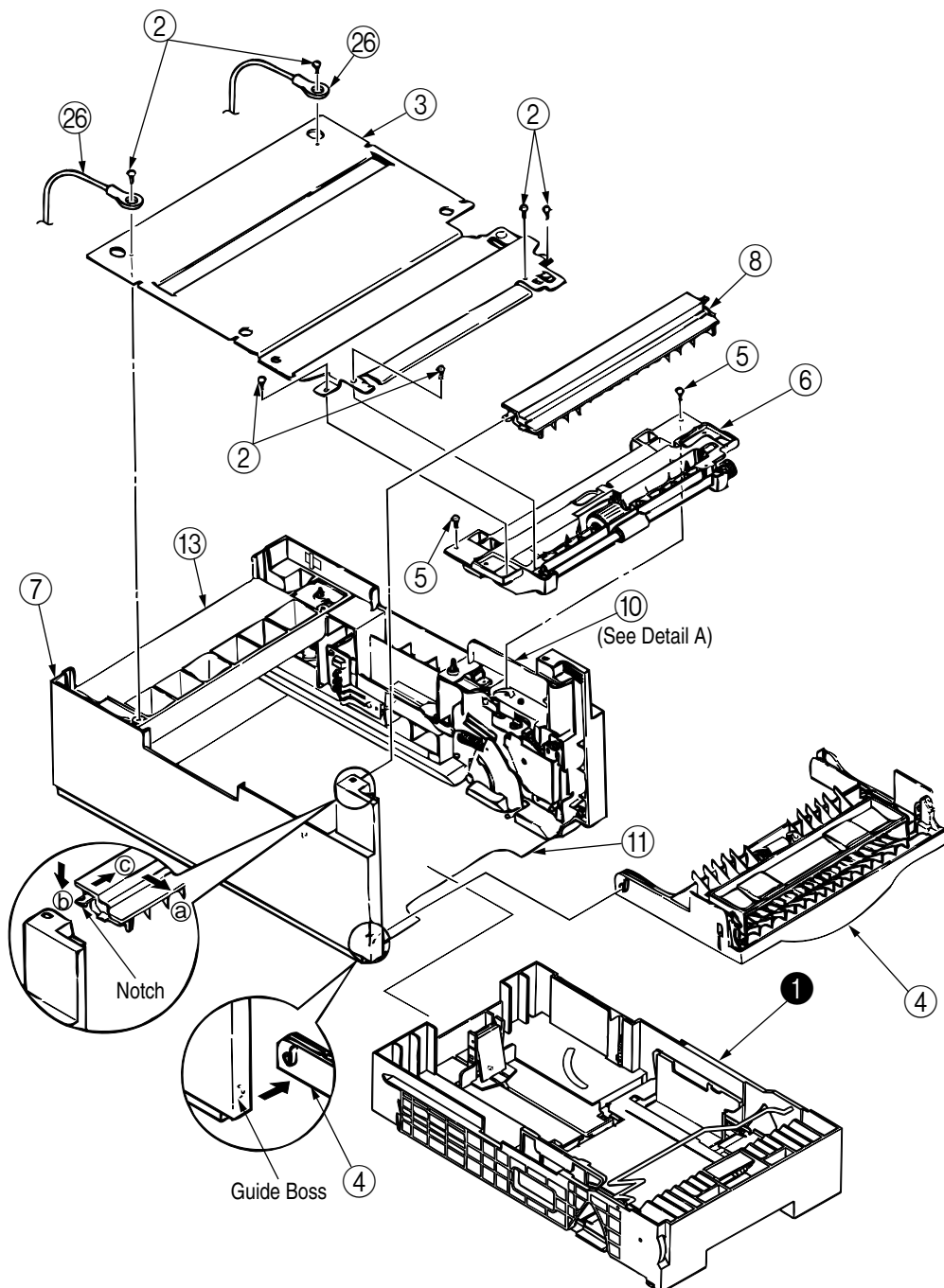

- (6) Remove three screws ⑨ which are holding the guide R (2nd) assy ⑩ to the bottom plate ⑪. Remove the screw ⑫ which is keeping the rear cover ⑬ and guide R (2nd) assy ⑩. Remove the guide R (2nd) assy ⑩.
- (7) Remove the protect (M) ⑭, guide bracket ⑮, planet gears ⑯ and planet gear bracket ⑰.
- (8) Remove the E-ring ⑱ which is keeping the sheet link ⑲ on the guide R (2nd) assy ⑩, and pull out the hinge stand ⑳.
- (9) Remove three remaining screws ㉑ which are keeping the motor on the motor bracket ㉒, and remove the connector off the Stepping Motor ㉓.
- (10) Remove two screws ㉔ on the Stepping Motor ㉓.

Note : The guide bracket ⑮ must be attached as shown in the following illustration:

No jutting of the gear shaft ⑰ is allowed into the oval hole ⑮.

Turn ⑮ clockwise for screw looseness to affix firmly.

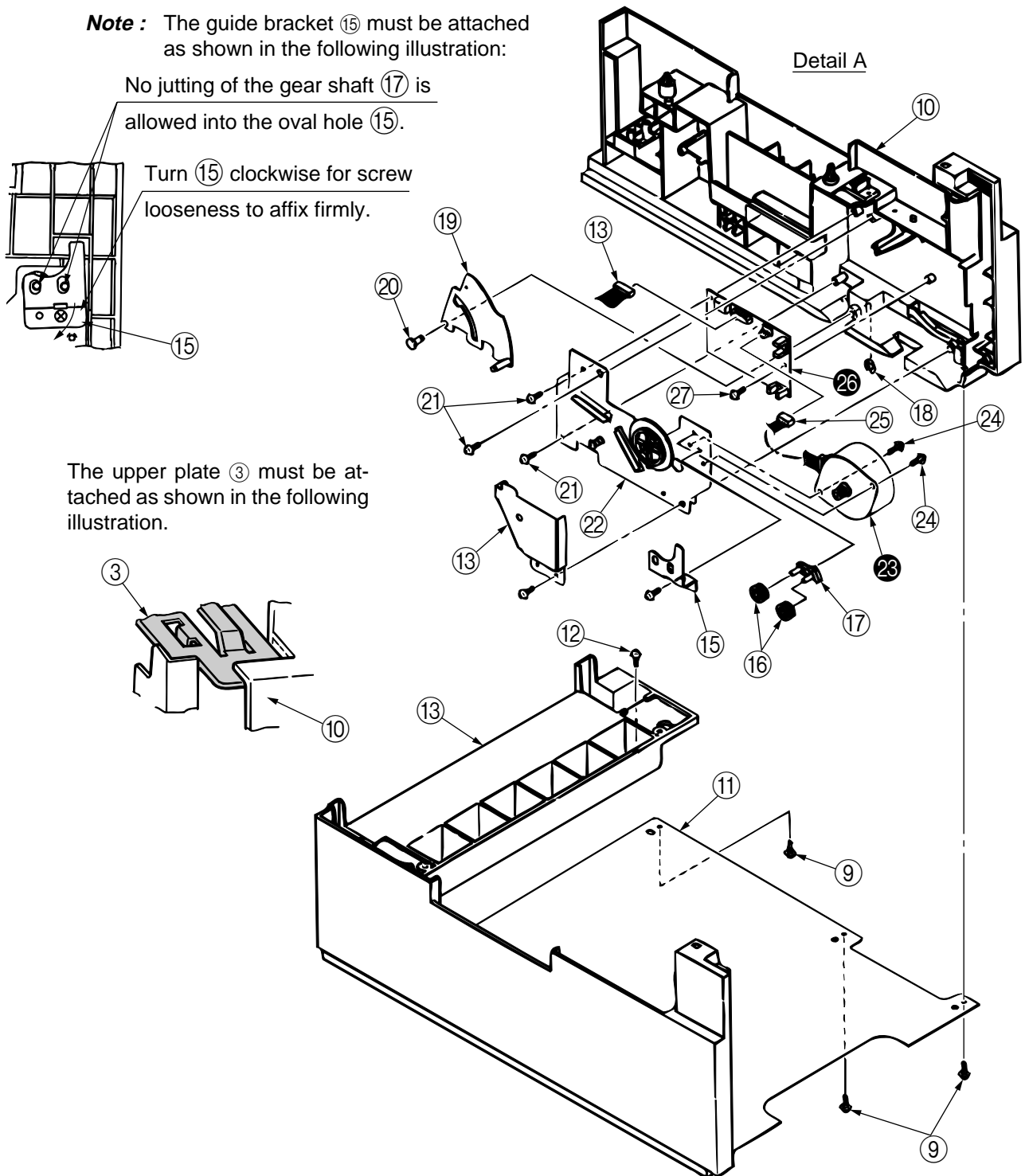

The upper plate ③ must be attached as shown in the following illustration.

3.3.2 TQSB-2 PCB

- (1) Remove the pulse motor (see 3.3.1).
- (2) Remove the connector ⑫ from the TQSB-2 PCB ⑫.
- (3) Remove the screw ⑮ and remove the TQSB-2 PCB ⑫.

Note : Refer to Detail A in the previous page.

3.3.3 Hopping Roller Shaft Assy and One-way Clutch Gear

- (1) Follow up to step (3) of 3.3.1 and remove the hopping frame assy.
- (2) Remove the screw ① and remove the earth plate ②. Remove the sensor lever (T) ⑦ and remove the tension spring ⑭ and remove the ground plate ⑥. Remove the gear ③ and remove the metal bush ⑤ and hopping roller shaft assy ④.
- (3) Remove the E-ring ⑪ and remove the one-way clutch gear ⑫ on the right side of the feed roller ⑩.

Note : The metal bush ⑬ also comes off. Be careful not to lose it.

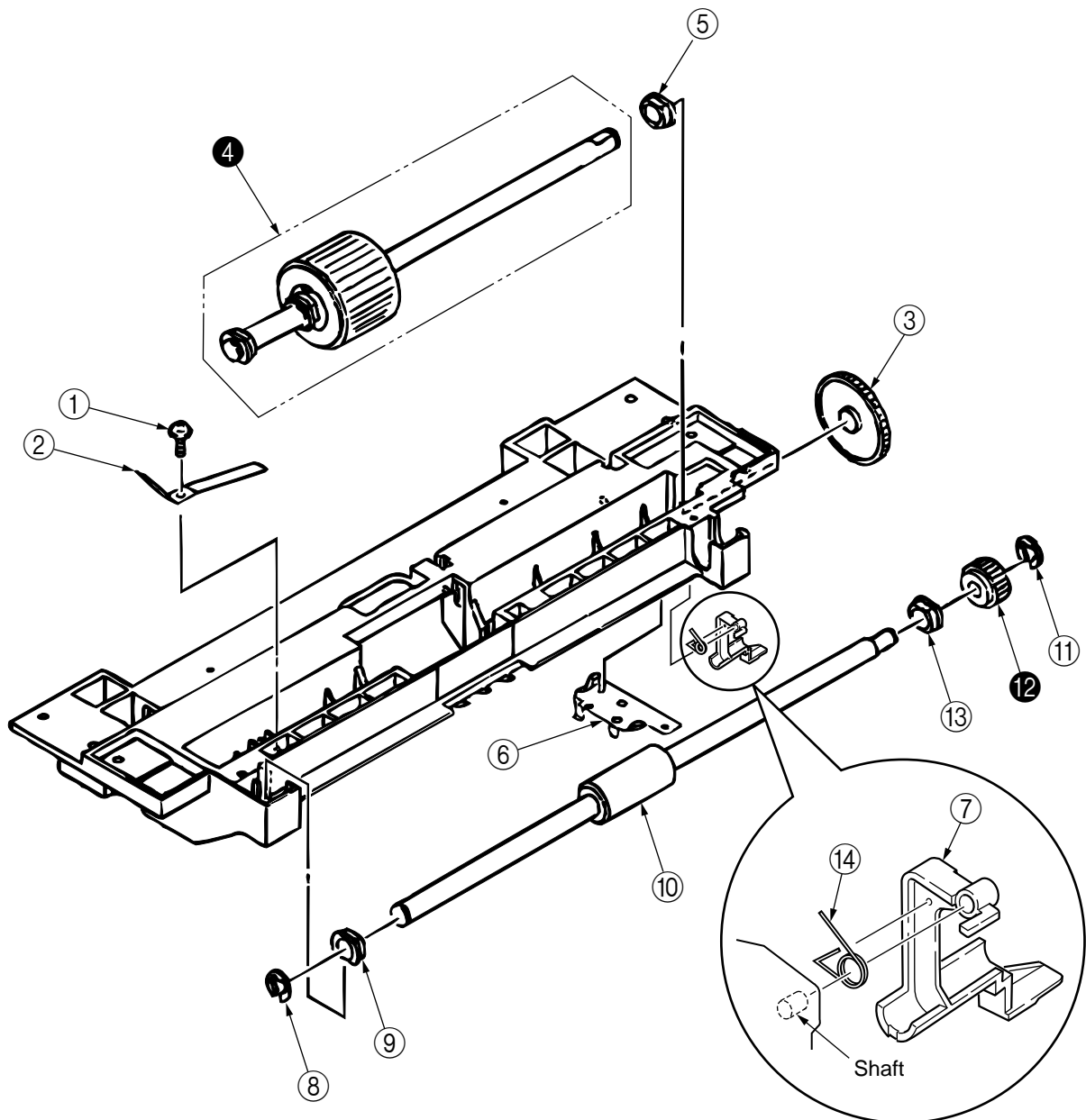

The tension lever and the sensor lever need concurrent replacing.

4. TROUBLESHOOTING

4.1 Precautions Prior to the Troubleshooting

- (1) Go through the basic checking items provided in the Printer Handbook.
- (2) Obtain detailed information concerning the problem from the user.
- (3) Go through checking in the conditions similar to that in which the problem occurred.

4.2 Preparations for the Troubleshooting

- (1) Display on the Operator panel
The status of the problem is displayed on LED on the Operator panel.

[ODA/OEL/INT]

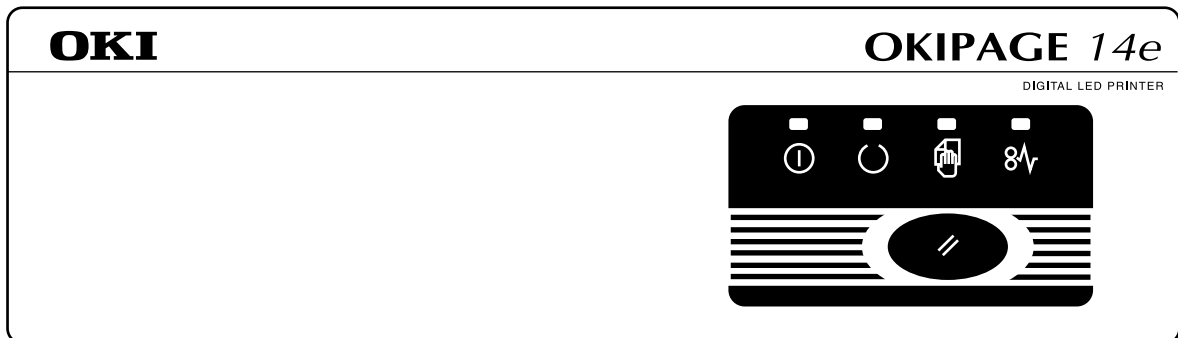

4.3 Troubleshooting Method



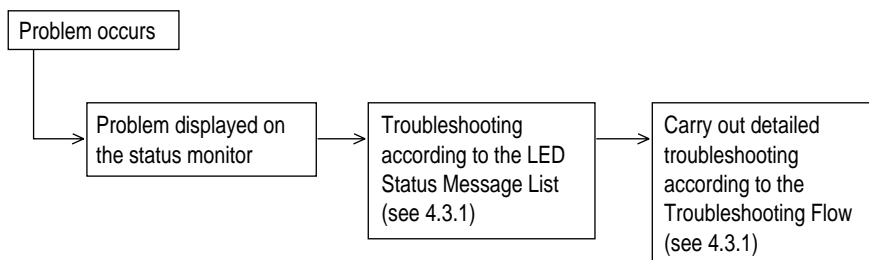

When a problem occurs, go through the troubleshooting according to the following procedure.



4.3.1 LED Status Message List

The listing of the statuses and problems displayed in the form of messages on the status monitor is provided in Table 4-1.

Table 4-1

Classification	LED Status Message	Description	Recovery method
Jam error (feeding)	 Blinking OFF OFF	Notifies of occurrence of jam while the paper is being fed from High Capacity Second Paper Feeder.	<ul style="list-style-type: none"> Check the paper in the High Capacity Second Paper Feeder. Carry out the recovery printing by opening and closing the cover, and turn the error display off. When the problem occurs frequently, go through the Troubleshooting.
Jam error (ejection)	 Blinking OFF OFF	Notifies of occurrence of jam while the paper is being ejected from the printer.	<ul style="list-style-type: none"> Check the paper in the printer. Carry out the recovery printing by opening and closing the cover, and turn the error display off.
Paper size error	 Blinking OFF OFF	Notifies of incorrect size paper feeding from High Capacity Second Paper Feeder.	<ul style="list-style-type: none"> Check the paper in the High Capacity Second Paper Feeder. Also check to see if there was a feeding of multiple sheets. Carry out the recovery printing by opening and closing the cover, and turn the error display off.
Tray paper out	 Blinking OFF OFF	Notifies of no paper state of the High Capacity Second Paper feeder.	<ul style="list-style-type: none"> Load the paper in High Capacity Second Paper Feeder.
Paper size request	 Blinking OFF OFF	Notifies of correct paper size for the High capacity Second Paper Feeder.	<ul style="list-style-type: none"> Load the requested size paper in the High Capacity Second Paper Feeder.

- (JAM error)

Paper Inlet Jam

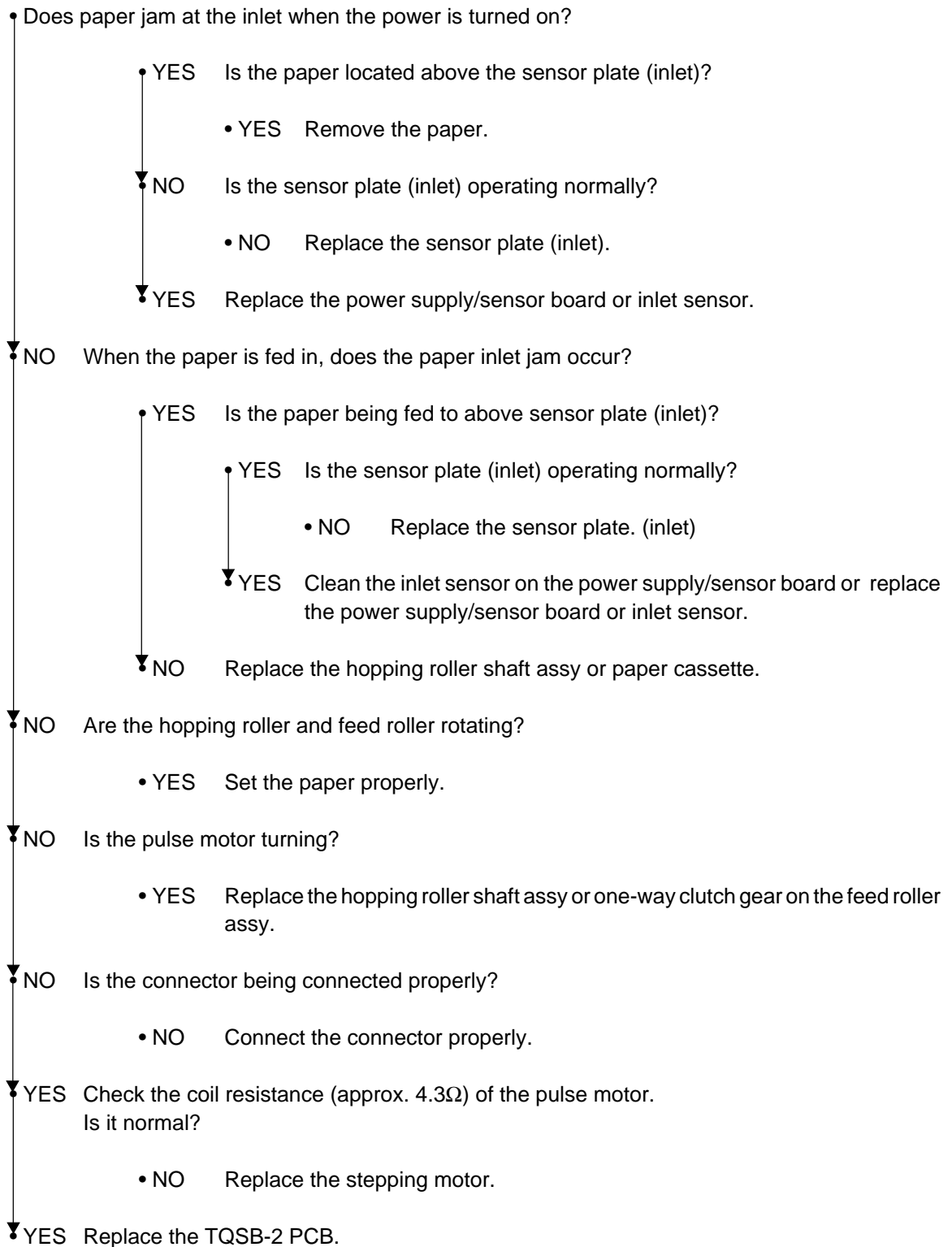

5. CONNECTION DIAGRAM

5.1 Interconnection Diagram

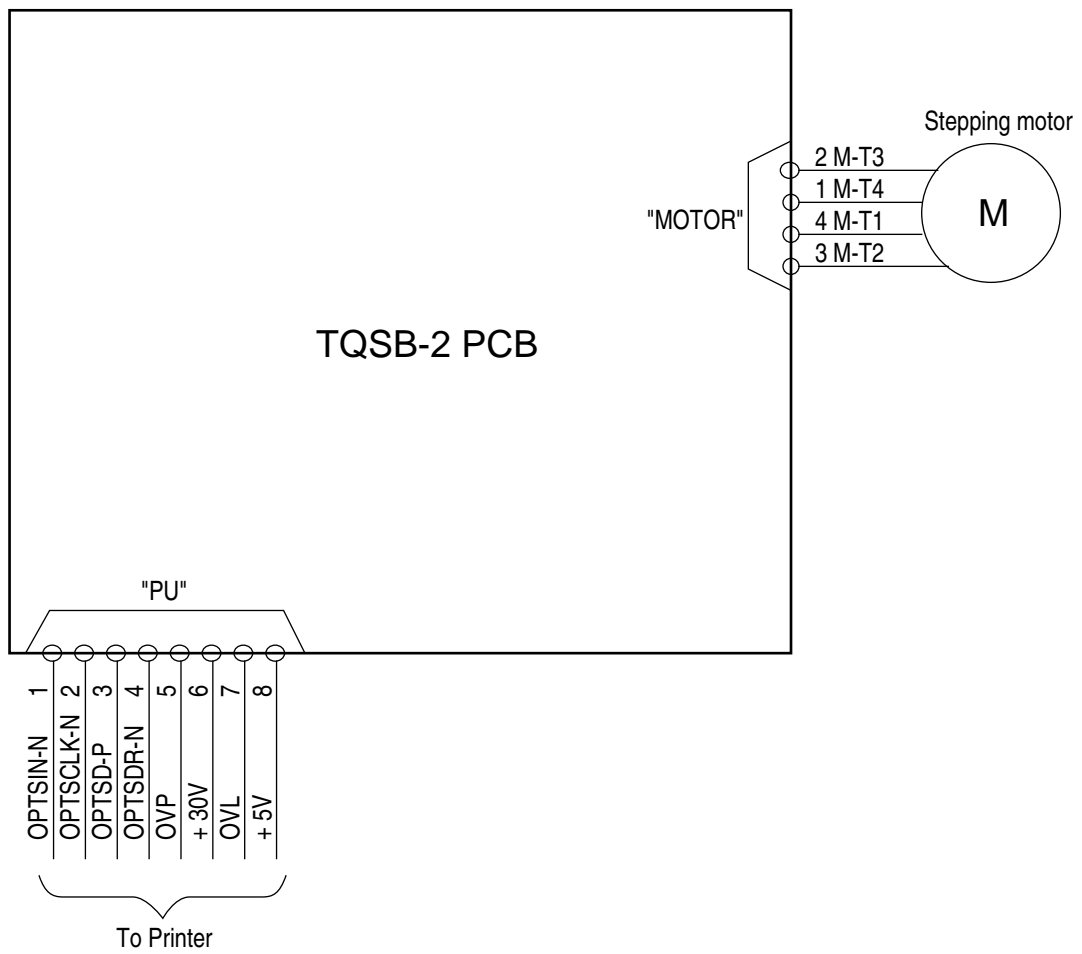

5.2 PCB Layout

TQSB-2 PCB

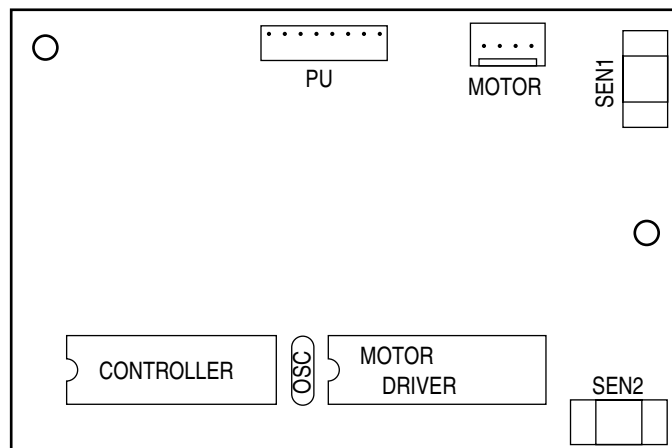

6. PARTS LIST

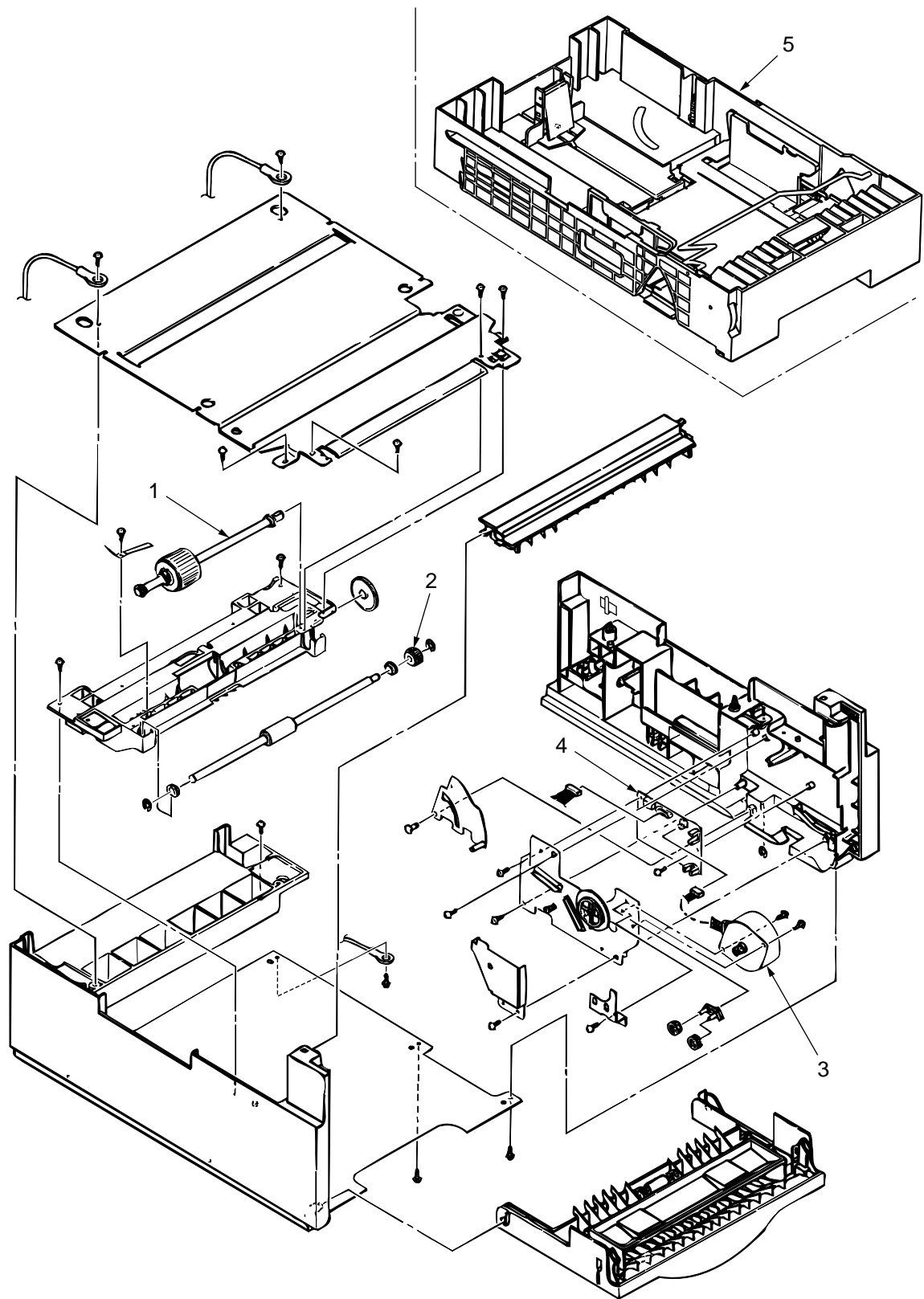

Figure 6-1 High Capacity Second Paper Feeder

Table 6-1 High Capacity Paper Feeder

No.	Description	OKI-J Part No.	Q'ty	Remark
1	Hopping roller shaft assy	3PA4122-1367G001	1	
2	One-way clutch gear	4PB4122-1382P001	1	
3	Stepping motor	3PB4122-1399P001	1	
4	TQSB-2 PCB	4YA4046-1651G002	1	
5	Cassette assy (2nd tray)	1PA4122-1362G004	1	

2nd Tray ASSEMBLY

SECTION1
CABINET & CASSETTE ASSEMBLY

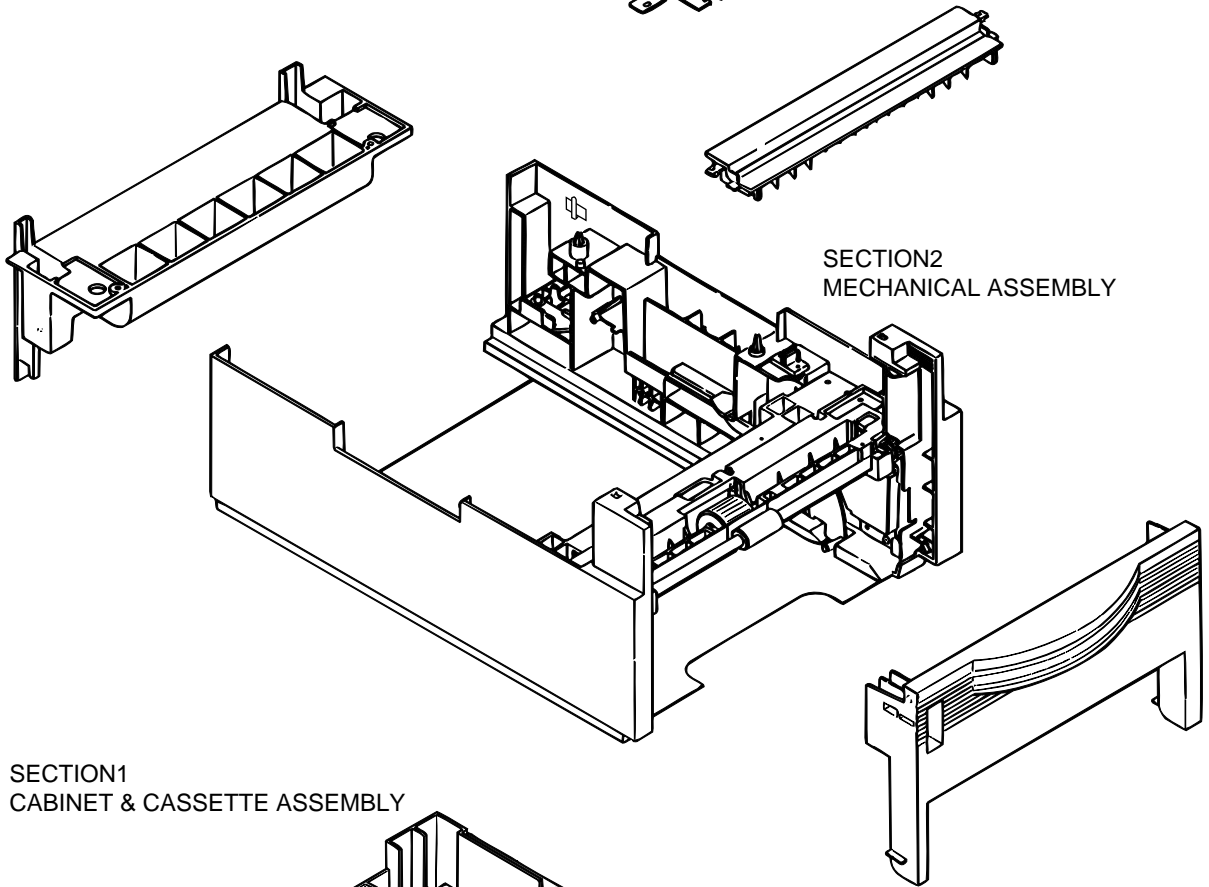
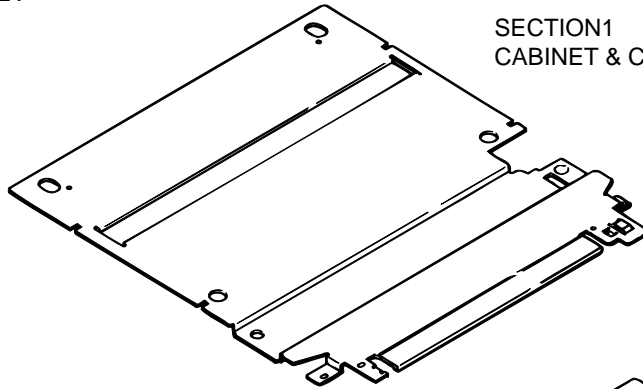

SECTION2
MECHANICAL ASSEMBLY

SECTION1
CABINET & CASSETTE ASSEMBLY

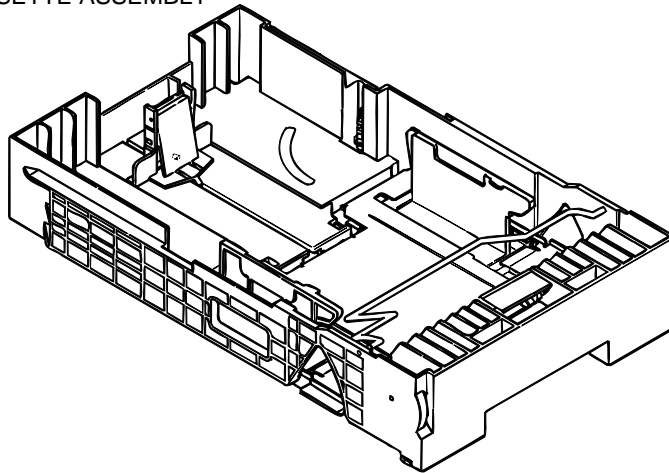

SECTION1 CABINET & CASSETTE ASSEMBLY

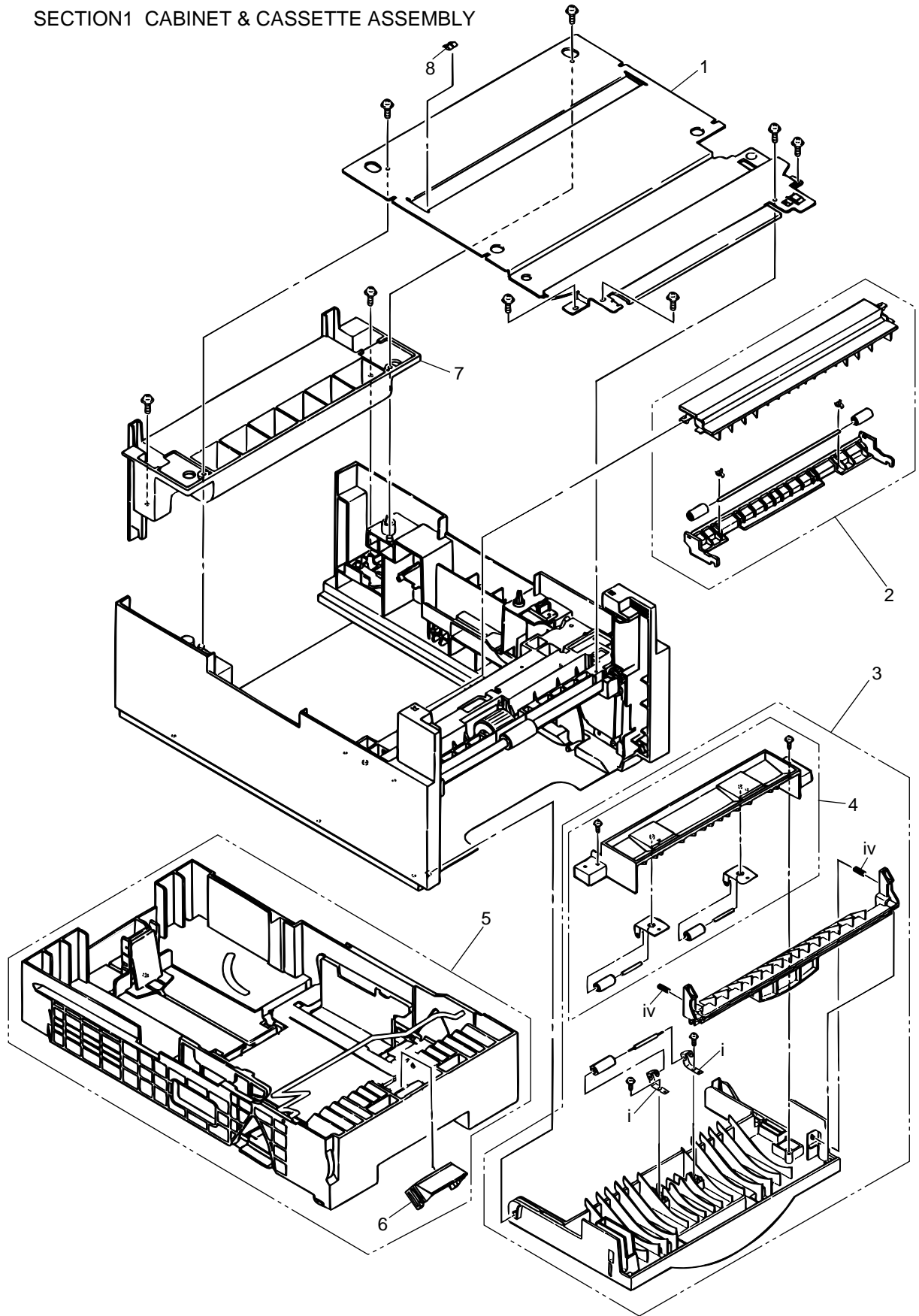

SECTION2 MECHANICAL ASSEMBLY

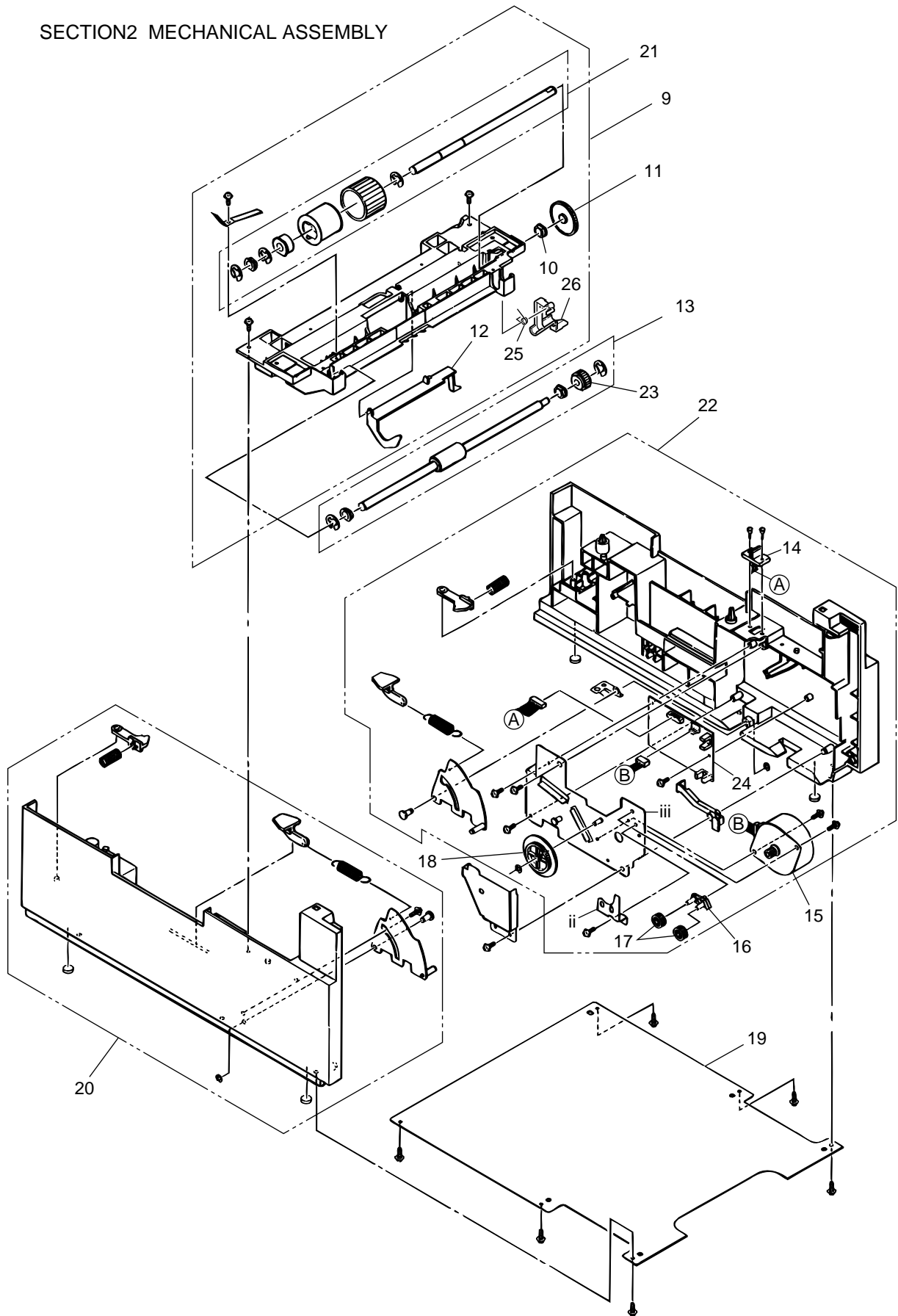

Table 6-2 2nd Tray Parts List

No.	Description	OKI Parts No.	Q'ty/U	500	1000
1	Plate, upper	1PP4122-1401P001	1	3	5
2	Sheet guide assembly	3PA4122-1370G001	1	3	5
3	Front cover assembly	1PA4122-1369G001*	1	3	5
4	Inner guide assembly	3PA4122-1371G001	1	3	5
5	Cassette assembly (2nd tray)	1PA4122-1362G004***	1	3	6
6	Separation frame assembly	4PP4120-1009G001	1	6	12
7	Cover, rear	1PA4122-1323P001	1	3	5
8	Stick finger	4PB4122-1441P001	1	3	5
9	Hopping flame assembly	1PA4122-1366G001	1	3	6
10	Bush, metal (ADF)	4PP3522-3568P001	1	3	5
11	Gear (z70)	4PP4122-1207P001	1	3	5
12	Lever, sensor (p)	3PP4122-1331P001	1	3	5
13	Feed roller assembly	3PA4122-1393G001	1	3	5
14	Cable & connector	3YS4111-3528P001	1	3	5
15	Stepping motor	3PB4122-1399P001	1	3	6
16	Bracket	4PP4122-1384G001	1	3	5
17	Gear (z24)	4PP4122-1383P001	2	3	5
18	Gear (z87/z60)	4PP4122-1226P001	1	3	5
19	Plate, bottom	2PP4122-1389P001	1	3	5
20	2nd cassette guide (L) assy	1PA4122-1365G001	1	3	6
21	Hopping roller assembly	3PA4122-1367G001	1	3	6
22	2nd cassette guide (R) assy	1YX4122-1364G002**	1	3	6
23	One-way clutch gear	4PB4122-1382P001	1	6	12
24	TQSB-2 PCB	4YA4046-1651G002	1	3	6
25	Spring, Tension	41804801	1	3	6
26	Lever, sensor (T)	PP4122-1416P001	1	3	6

* For the rev. no. of the Parts List for the Front cover assembly should be applied Ver.6.
The Ver.6 includes a change of Release spring [P.179, iv]

** For the rev. no. of the Parts List for the 2nd cassette guide (R) assy should be applied Ver.5.
In the Ver.5, the oval hole in the Guide Bracket [P.180, ii] and the hole in the Motor Bracket [P.180, iii] are relocated as shown in the following illustrations, respectively:

Guide Bracket Part No.:4PP4122-1392P001

Motor Bracket Part No.:3PP4122-1345P001

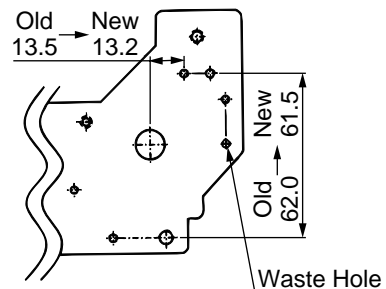
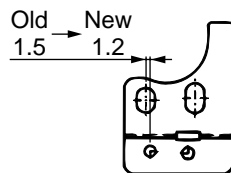

Note : Parts Nos. 3 and 22 need concurrent replacing.

*** For the rev. no. of the Parts List for the Cassette assembly (2nd tray) should be applied No.10.
The No.10 includes a change of cassette and Tale Guide.

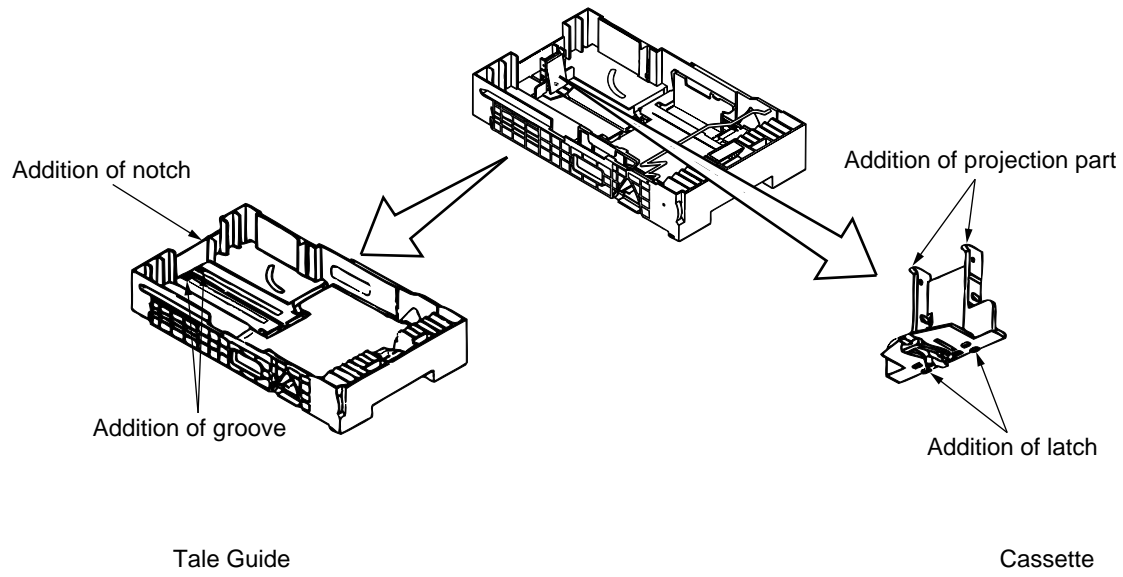

Note : Cassette and Tale Guide need concurrent replacing.